

2ATPF**/**/**TF02***

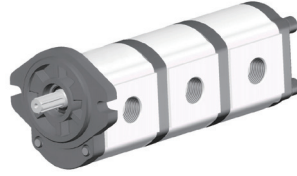

型号	排量 (ml/r)	压力(bar)		转速(r/min)			L (mm)	L1 (mm)	进油口			出油口		
		额定	最高	额定	最高	最低			φD1	φd1	T1	φD2	φd2	T2
2APF04F60*	4	200	250	2000	3500	500	87.9	42.2	40	15	M6	30	15	M6
2APF06F60*	6	200	250	2000	3500	500	91.1	43.8						
2APF08F52*	8	200	250	2000	3500	500	94.3	45.4						
2APF10F52*	10	200	250	2000	3500	500	97.5	47.0						
2APF12F52*	12	200	250	2000	3500	500	110.7	48.6	40	20	M6	30	15	M6
2APF14F52*	14	200	250	2000	3500	500	114.0	50.2						
2APF16F52*	16	200	250	2000	3500	500	109.5	51.2						
2APF18F52*	18	200	250	2000	3500	500	113.0	52.8						
2APF20F52*	20	200	250	2000	3500	500	116.5	55.3	40	20	M6	30	15	M6
2APF23F52*	23	200	250	2000	3000	500	121.5	56.9						
2APF25F52*	25	200	250	2000	3000	500	124.7	58.5						

外形尺寸

2TPF**/**/**TF02T2008* 三联泵

选项: 2TPF**/**/**TF02F63D9*

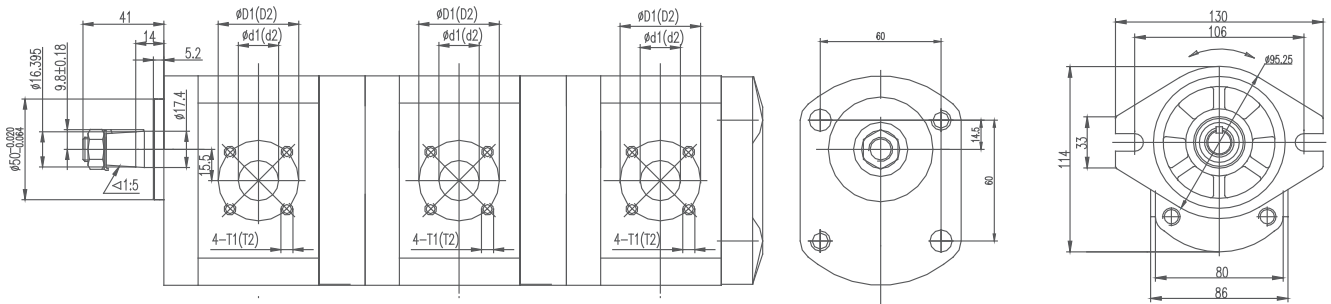

2APF**F52T2008*-A

2APF**F52*-M

2APF**F52*-B

