

## 2CB-E\*\*/\*\* 高低压齿轮泵

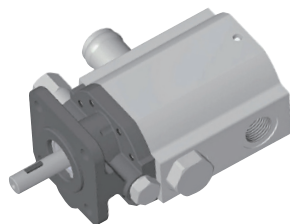

| 型号            | 流量<br>(gpm) | 压力(Psi) |      | 排量(Cu.in/r) |       | 转速<br>(rpm) | D         |         |
|---------------|-------------|---------|------|-------------|-------|-------------|-----------|---------|
|               |             | 低       | 高    | 低           | 高     |             | 进油口       | 出油口     |
| 2CB-E6.3/2.1  | 8           | 400/900 | 3000 | 0.385       | 0.130 | 3600        | 1 IN PIPE | 1/2 NPT |
| 2CB-E6.3/3.0  | 8.5         | 400/900 | 3000 | 0.385       | 0.183 |             |           |         |
| 2CB-E6.3/3.6  | 9           | 400/900 | 3000 | 0.385       | 0.220 |             |           |         |
| 2CB-E8.8/2.1  | 10          | 400/900 | 3000 | 0.537       | 0.130 |             |           |         |
| 2CB-E8.8/3.0  | 10.5        | 400/900 | 3000 | 0.537       | 0.183 |             |           |         |
| 2CB-E8.8/3.6  | 11          | 400/900 | 3000 | 0.537       | 0.220 |             |           |         |
| 2CB-E8.8/4.2  | 11.5        | 400/900 | 3000 | 0.537       | 0.256 |             |           |         |
| 2CB-E10.9/2.1 | 12          | 400/900 | 3000 | 0.665       | 0.130 |             |           |         |
| 2CB-E10.9/3.0 | 12.5        | 400/900 | 3000 | 0.665       | 0.183 |             |           |         |
| 2CB-E10.9/3.6 | 13          | 400/900 | 3000 | 0.665       | 0.220 |             |           |         |
| 2CB-E10.9/4.2 | 13.5        | 400/900 | 3000 | 0.665       | 0.256 |             |           |         |
| 2CB-E13.0/4.2 | 16          | 400/900 | 3000 | 0.793       | 0.265 |             |           |         |

## 外形尺寸

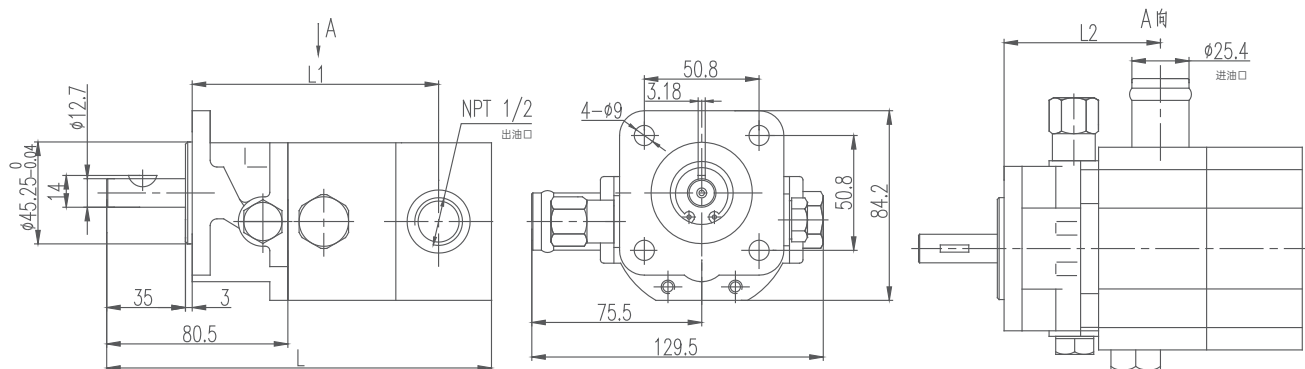

| 型号           | 尺寸(in) |      |      | 型号            | 尺寸(in) |      |      | 型号            | 尺寸(in) |      |      |
|--------------|--------|------|------|---------------|--------|------|------|---------------|--------|------|------|
|              | L      | L1   | L2   |               | L      | L1   | L2   |               | L      | L1   | L2   |
| 2CB-E6.3/2.1 | 6.07   | 3.74 | 2.41 | 2CB-E8.8/3.0  | 6.54   | 4.08 | 2.74 | 2CB-E10.9/3.0 | 6.90   | 4.53 | 3.04 |
| 2CB-E6.3/3.0 | 6.21   | 3.90 | 2.41 | 2CB-E8.8/3.6  | 6.61   | 4.24 | 2.74 | 2CB-E10.9/3.6 | 7.00   | 4.53 | 3.04 |
| 2CB-E6.3/3.6 | 6.28   | 3.90 | 2.74 | 2CB-E8.8/4.2  | 6.70   | 4.24 | 2.74 | 2CB-E10.9/4.2 | 7.09   | 4.53 | 3.04 |
| 2CB-E8.8/2.1 | 6.41   | 4.08 | 2.74 | 2CB-E10.9/2.1 | 6.70   | 4.37 | 3.04 | 2CB-E13.0/4.2 | 6.70   | 4.37 | 3.04 |