

GT系列摆线马达

可选功能

- 法兰和圆形安装
- 无轴承马达
- 马达带后制动器
- 转速器接头
- 速度传感
- 侧面和后油口
- 轴伸：平键、花键、锥键
- 公制和BSPP油口
- 其他功能

应用

- 金属加工器械
- 农用机械
- 铺路机
- 开矿机
- 食品工业
- 特殊设备
- 注塑机
- 输送机械







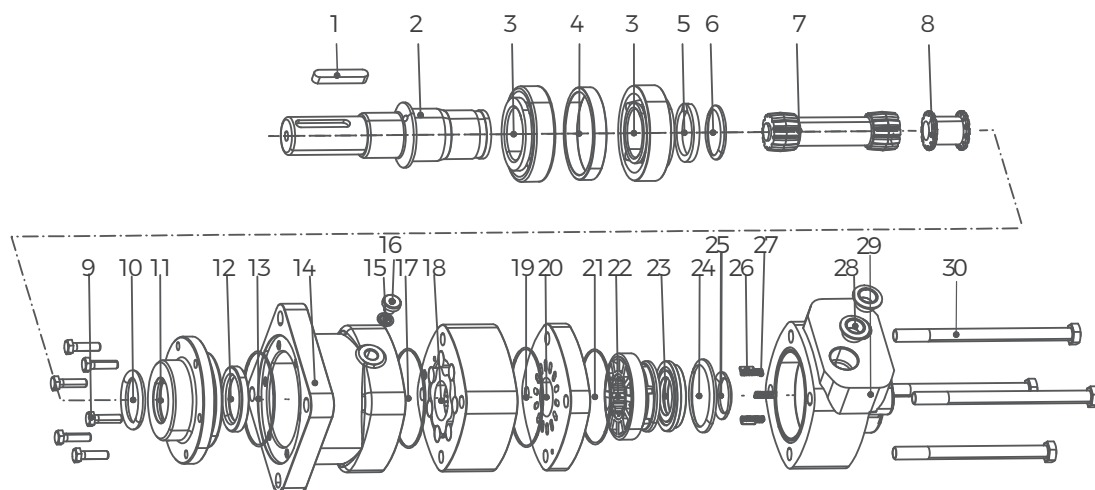







































一般参数

最大排量	cm ³ /rev [in ³ /rev]	724.3 [44.2]
最高转速	RPM	775
最大扭矩	daNm [lb-in]	连续: 130 [11500] 断续: 148 [13100]
最大输出功率	kW [HP]	40 [54]
	bar [PSI]	连续: 200 [2900] 断续: 240 [3480]
最大流量	lpm [GPM]	150 [39.6]
最低转速	RPM	5
允许的轴向载荷	daNm [lbs]	Pa=1000 [2250]
工作油液		矿物油 HLP (DIN 51524) 或 HM (ISO 6743/4)
温度范围	°C[°F]	-40至140 [-40至284]
粘度范围	mm ² /s [SUS]	20至75 [98至347]
过滤		ISO 代码 20/16 (推荐液体过滤精度 25微米)



- | | | | | | |
|----------|--------|---------|------------------|---------|---------|
| 1 平键 | 6 隐形圈 | 11 前盖 | 16 9/16-18UNF 堵头 | 21 O型圈 | 26 定位销 |
| 2 输出轴 | 7 传动轴 | 12 骨架油封 | 17 O型圈 | 22 配流盘 | 27 弹簧 |
| 3 圆锥滚子轴承 | 8 联动轴 | 13 O型圈 | 18 转定子副总成 | 23 配流压盘 | 28 油口堵盖 |
| 4 轴承外挡圈 | 9 六角螺钉 | 14 壳体 | 19 O型圈 | 24 大异性圈 | 29 后壳体 |
| 5 开口垫圈 | 10 O型圈 | 15 组合垫 | 20 平衡盘 | 25 小异性圈 | 30 螺钉 |

订购代码

CT 系列	排量	法兰	输出轴	油口 泄油口	旋向	油漆	特殊功能																																																																													
<table border="1"> <thead> <tr> <th>代码</th> <th>系列</th> </tr> </thead> <tbody> <tr> <td>GT</td> <td>摆线马达</td> </tr> <tr> <td>GTS</td> <td>无轴承马达</td> </tr> </tbody> </table>	代码	系列	GT	摆线马达	GTS	无轴承马达	<table border="1"> <thead> <tr> <th>代码</th> <th>排量</th> </tr> </thead> <tbody> <tr> <td>160</td> <td>1611cm³/rev [9.83in³/rev]</td> </tr> <tr> <td>200</td> <td>201.4cm³/rev [12.29in³/rev]</td> </tr> <tr> <td>250</td> <td>251.8cm³/rev [15.36in³/rev]</td> </tr> <tr> <td>315</td> <td>326.3cm³/rev [19.90in³/rev]</td> </tr> <tr> <td>400</td> <td>410.9cm³/rev [25.06in³/rev]</td> </tr> <tr> <td>500</td> <td>523.6cm³/rev [31.95in³/rev]</td> </tr> <tr> <td>630</td> <td>631.2cm³/rev [38.52in³/rev]</td> </tr> <tr> <td>725</td> <td>724.3cm³/rev [44.2in³/rev]</td> </tr> </tbody> </table>	代码	排量	160	1611cm ³ /rev [9.83in ³ /rev]	200	201.4cm ³ /rev [12.29in ³ /rev]	250	251.8cm ³ /rev [15.36in ³ /rev]	315	326.3cm ³ /rev [19.90in ³ /rev]	400	410.9cm ³ /rev [25.06in ³ /rev]	500	523.6cm ³ /rev [31.95in ³ /rev]	630	631.2cm ³ /rev [38.52in ³ /rev]	725	724.3cm ³ /rev [44.2in ³ /rev]	<table border="1"> <thead> <tr> <th>代码</th> <th>法兰</th> </tr> </thead> <tbody> <tr> <td>H6</td> <td>4-φ14 方法兰 φ160 止口 φ125×9 </td> </tr> <tr> <td>H7</td> <td>4-φ14.5 方法兰 φ162 止口 φ127×9 </td> </tr> <tr> <td>W2</td> <td>4-φ18 轮式法兰 φ200 止口 φ160×7 </td> </tr> <tr> <td>B2</td> <td>4-φ14 圆法兰 φ160 止口 φ125×8 </td> </tr> <tr> <td>H8</td> <td>4-φ14.5 方法兰 φ162 止口 φ127×10 </td> </tr> </tbody> </table>	代码	法兰	H6	4-φ14 方法兰 φ160 止口 φ125×9 	H7	4-φ14.5 方法兰 φ162 止口 φ127×9 	W2	4-φ18 轮式法兰 φ200 止口 φ160×7 	B2	4-φ14 圆法兰 φ160 止口 φ125×8 	H8	4-φ14.5 方法兰 φ162 止口 φ127×10 	<table border="1"> <thead> <tr> <th>代码</th> <th>油口 泄油口</th> </tr> </thead> <tbody> <tr> <td>G3</td> <td>G3/4 板式 4×M10, G1/4</td> </tr> <tr> <td>M5</td> <td>M27×2 板式 4×M10, M14×1.5</td> </tr> <tr> <td>U4</td> <td>1-1/16-12UN O型圈, 9/16-18UNF</td> </tr> <tr> <td>U5</td> <td>1-1/16-12UN O型圈, 7/16-20UNF</td> </tr> <tr> <td>G4</td> <td>G3/4, G1/4</td> </tr> <tr> <td>M9</td> <td>M27×2, M14×1.5</td> </tr> </tbody> </table>	代码	油口 泄油口	G3	G3/4 板式 4×M10, G1/4	M5	M27×2 板式 4×M10, M14×1.5	U4	1-1/16-12UN O型圈, 9/16-18UNF	U5	1-1/16-12UN O型圈, 7/16-20UNF	G4	G3/4, G1/4	M9	M27×2, M14×1.5	<table border="1"> <thead> <tr> <th>代码</th> <th>油漆</th> </tr> </thead> <tbody> <tr> <td>A</td> <td>不涂漆</td> </tr> <tr> <td>B</td> <td>蓝色</td> </tr> <tr> <td>C</td> <td>黑色</td> </tr> <tr> <td>S</td> <td>银灰色</td> </tr> </tbody> </table>	代码	油漆	A	不涂漆	B	蓝色	C	黑色	S	银灰色	<table border="1"> <thead> <tr> <th>代码</th> <th>特殊功能</th> </tr> </thead> <tbody> <tr> <td>A</td> <td>标准</td> </tr> <tr> <td>F</td> <td>自由转</td> </tr> <tr> <td>L</td> <td>低速</td> </tr> <tr> <td>V</td> <td>高温</td> </tr> <tr> <td>S</td> <td>低温</td> </tr> </tbody> </table>	代码	特殊功能	A	标准	F	自由转	L	低速	V	高温	S	低温	<table border="1"> <thead> <tr> <th>代码</th> <th>旋向</th> </tr> </thead> <tbody> <tr> <td>A</td> <td>标准</td> </tr> <tr> <td>R</td> <td>反向</td> </tr> </tbody> </table>	代码	旋向	A	标准	R	反向
代码	系列																																																																																			
GT	摆线马达																																																																																			
GTS	无轴承马达																																																																																			
代码	排量																																																																																			
160	1611cm ³ /rev [9.83in ³ /rev]																																																																																			
200	201.4cm ³ /rev [12.29in ³ /rev]																																																																																			
250	251.8cm ³ /rev [15.36in ³ /rev]																																																																																			
315	326.3cm ³ /rev [19.90in ³ /rev]																																																																																			
400	410.9cm ³ /rev [25.06in ³ /rev]																																																																																			
500	523.6cm ³ /rev [31.95in ³ /rev]																																																																																			
630	631.2cm ³ /rev [38.52in ³ /rev]																																																																																			
725	724.3cm ³ /rev [44.2in ³ /rev]																																																																																			
代码	法兰																																																																																			
H6	4-φ14 方法兰 φ160 止口 φ125×9 																																																																																			
H7	4-φ14.5 方法兰 φ162 止口 φ127×9 																																																																																			
W2	4-φ18 轮式法兰 φ200 止口 φ160×7 																																																																																			
B2	4-φ14 圆法兰 φ160 止口 φ125×8 																																																																																			
H8	4-φ14.5 方法兰 φ162 止口 φ127×10 																																																																																			
代码	油口 泄油口																																																																																			
G3	G3/4 板式 4×M10, G1/4																																																																																			
M5	M27×2 板式 4×M10, M14×1.5																																																																																			
U4	1-1/16-12UN O型圈, 9/16-18UNF																																																																																			
U5	1-1/16-12UN O型圈, 7/16-20UNF																																																																																			
G4	G3/4, G1/4																																																																																			
M9	M27×2, M14×1.5																																																																																			
代码	油漆																																																																																			
A	不涂漆																																																																																			
B	蓝色																																																																																			
C	黑色																																																																																			
S	银灰色																																																																																			
代码	特殊功能																																																																																			
A	标准																																																																																			
F	自由转																																																																																			
L	低速																																																																																			
V	高温																																																																																			
S	低温																																																																																			
代码	旋向																																																																																			
A	标准																																																																																			
R	反向																																																																																			
			<table border="1"> <thead> <tr> <th>代码</th> <th>输出轴</th> </tr> </thead> <tbody> <tr> <td>C2</td> <td>万向轴 16-DP 12/24 </td> </tr> <tr> <td>SK</td> <td>φ40轴 平键 12×8×70 </td> </tr> <tr> <td>SL</td> <td>φ38.1轴 平键 9.53×9.53×57.15 </td> </tr> <tr> <td>R9</td> <td>φ38.1轴 花键 17-DP 12/24 </td> </tr> <tr> <td>RA</td> <td>φ38.1轴 花键 17-DP 12/24 </td> </tr> <tr> <td>T6</td> <td>φ45锥轴 1:10 平键 B12×8×28 </td> </tr> <tr> <td>T7</td> <td>φ45锥轴 1:8 平键 11.13×11.13×31.75 </td> </tr> <tr> <td>R7</td> <td>φ34.85轴 花键6-34.85×28.14×8.64 </td> </tr> <tr> <td>SM</td> <td>φ31.75 平键 7.96×7.96×40 </td> </tr> <tr> <td>R3</td> <td>φ31.75轴 花键 14-DP 12/24 </td> </tr> </tbody> </table>	代码	输出轴	C2	万向轴 16-DP 12/24 	SK	φ40轴 平键 12×8×70 	SL	φ38.1轴 平键 9.53×9.53×57.15 	R9	φ38.1轴 花键 17-DP 12/24 	RA	φ38.1轴 花键 17-DP 12/24 	T6	φ45锥轴 1:10 平键 B12×8×28 	T7	φ45锥轴 1:8 平键 11.13×11.13×31.75 	R7	φ34.85轴 花键6-34.85×28.14×8.64 	SM	φ31.75 平键 7.96×7.96×40 	R3	φ31.75轴 花键 14-DP 12/24 																																																											
代码	输出轴																																																																																			
C2	万向轴 16-DP 12/24 																																																																																			
SK	φ40轴 平键 12×8×70 																																																																																			
SL	φ38.1轴 平键 9.53×9.53×57.15 																																																																																			
R9	φ38.1轴 花键 17-DP 12/24 																																																																																			
RA	φ38.1轴 花键 17-DP 12/24 																																																																																			
T6	φ45锥轴 1:10 平键 B12×8×28 																																																																																			
T7	φ45锥轴 1:8 平键 11.13×11.13×31.75 																																																																																			
R7	φ34.85轴 花键6-34.85×28.14×8.64 																																																																																			
SM	φ31.75 平键 7.96×7.96×40 																																																																																			
R3	φ31.75轴 花键 14-DP 12/24 																																																																																			



性能参数

类型		GT160	GT200	GT250	GT315
排量 cm ³ /rev [in ³ /rev]		161,1[9.83]	201,4[12.29]	251,8[15.36]	326,3[19.90]
最高转速	连续	622	620	496	382
RPM	断续	775	752	601	461
最大扭矩	连续	47[4160]	59[5220]	73[6460]	95[8410]
daNm [lb-in]	断续	56[4960]	71[6285]	88[7790]	114[10090]
	峰值	66[5840]	82[7260]	102[9030]	133[11770]
最大功率	连续	26,5[36]	33,5[45]	33,5[45]	33,5[45]
kW[HP]	断续	32[43]	40[54]	40[54]	40[54]
最大压力降	连续	200[2900]	200[2900]	200[2900]	200[2900]
bar [PSI]	断续	240[3480]	240[3480]	240[3480]	240[3480]
	峰值	280[4050]	280[4050]	280[4050]	280[4050]
最大流量	连续	100[26]	125[33]	125[33]	125[33]
lpm [GPM]	断续	125[33]	150[39.6]	150[39.6]	150[39.6]
最大进油压力	连续	210[3050]	210[3050]	210[3050]	210[3050]
bar [PSI]	断续	250[3600]	250[3600]	250[3600]	250[3600]
	峰值	300[4350]	300[4350]	300[4350]	300[4350]
最大泄油口回油压力	连续	140[2030]	140[2030]	140[2030]	140[2000]
bar [PSI]	断续	175[2540]	175[2540]	175[2540]	175[2500]
	峰值	210[3050]	210[3050]	210[3050]	210[3000]
最大开启压力无径向载荷 bar [PSI]		10[150]	10[150]	10[150]	10[150]
最小开启扭矩	最大压力降 连续	34[3010]	43[3800]	53[4690]	74[6550]
daNm [lb-in]	最大压力降 断续	41[3630]	52[4600]	63[5580]	89[7880]
最低转速		10	9	8	7
重量 kg [lb]	GT	20[44.1]	21,5[47.4]	21[46.3]	22[48.5]
后油口 + 0450 [1.992]	GTS	15[33.1]	15,5[34.2]	16[35.3]	17[37.5]

性能参数

类型		GT400	GT500	GT630	GT725
排量 cm ³ /rev [in ³ /rev]		410,9[25.06]	523,6[31.95]	631,2[38.52]	724,3[44.2]
最高转速	连续	304	238	197	172
RPM	断续	368	289	234	209
最大扭矩	连续	108[9560]	122[10800]	130[11500]	127[11240]
daNm [lb-in]	断续	126[11150]	137[12125]	148[13100]	147[13010]
	峰值	144[12745]	160[14160]	176[15580]	175[15490]
最大功率	连续	30[40]	26,5[36]	24,3[33]	20,2[27]
kW [HP]	断续	35[47]	30[40]	27,5[37]	26,8[36]
最大压力降	连续	180[2610]	160[2320]	140[2010]	120[1740]
bar [PSI]	断续	210[3050]	180[2610]	160[2320]	140[2010]
	峰值	240[3480]	210[3050]	190[2760]	165[2395]
最大流量	连续	125[33]	125[33]	125[33]	125[33]
lpm [GPM]	断续	150[39.6]	150[39.6]	150[39.6]	150[39.6]
最大进油压力	连续	210[3050]	210[3050]	210[3050]	210[3050]
bar [PSI]	断续	250[3600]	250[3600]	250[3600]	250[3600]
	峰值	300[4350]	300[4350]	300[2000]	300[4350]
最大泄油口回油压力	连续	140[2000]	140[2000]	140[2500]	140[2000]
bar [PSI]	断续	175[2500]	175[2500]	175[3000]	175[2500]
	峰值	210[3000]	210[3000]	210[3000]	210[3000]
最大开启压力无径向载荷 bar [PSI]		10[150]	10[150]	10[150]	10[150]
最小开启扭矩	最大压力降 连续	84[7435]	95[8410]	95[8410]	95[8410]
daNm [lb-in]	最大压力降 断续	97[8585]	106[9380]	110[9740]	115[10180]
最低转速		6	5	5	5
重量 kg [lb]	GT	23[50.7]	24[52.9]	23,5[51.8]	24,5[54.0]
后油口 + 0450 [.992]	GTS	18[39.7]	19[41.9]	18,5[40.8]	19,5[43.0]

性能曲线图

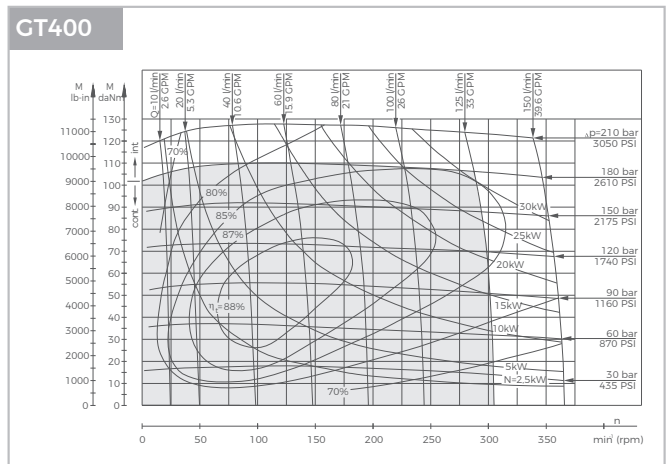
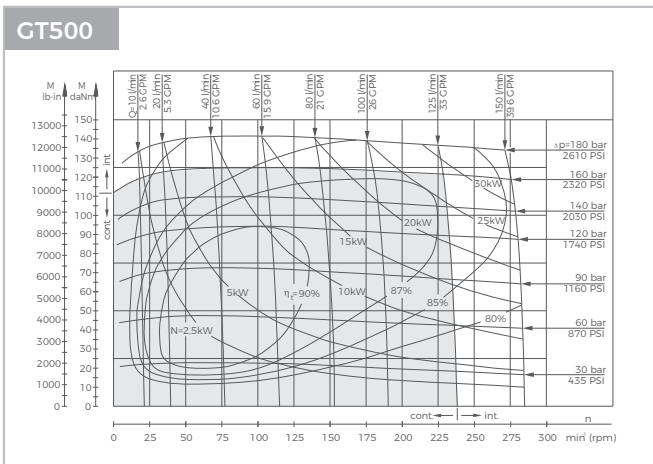
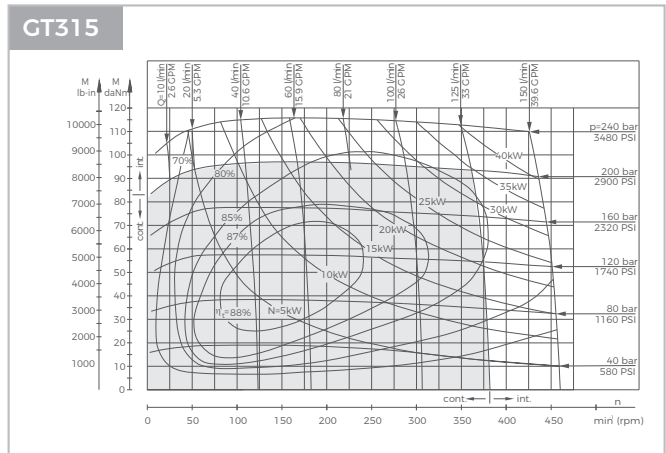
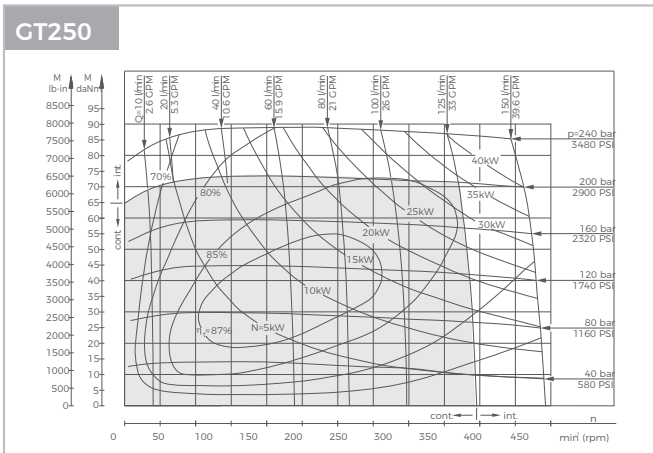
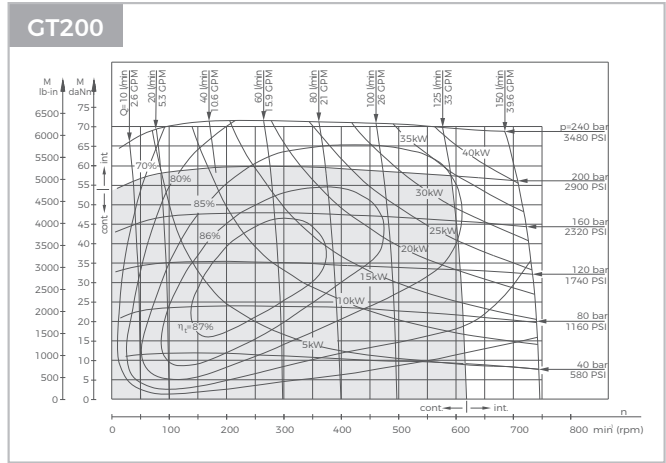
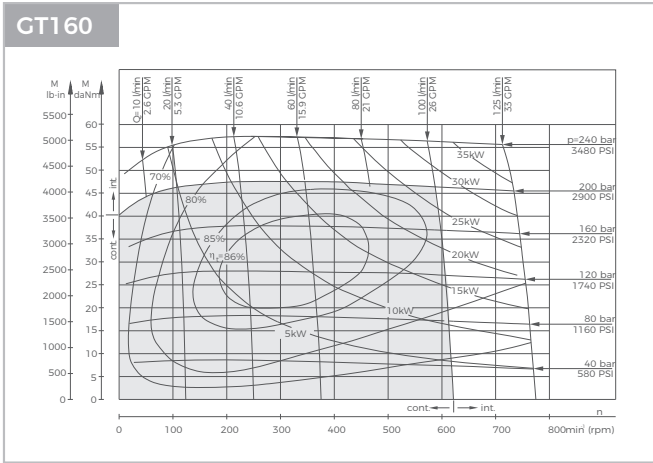

性能图是基于随机选出马达的平均参数，工况为背压0.5-1兆帕，粘度32mm²/s, 50 °C。

性能曲线图

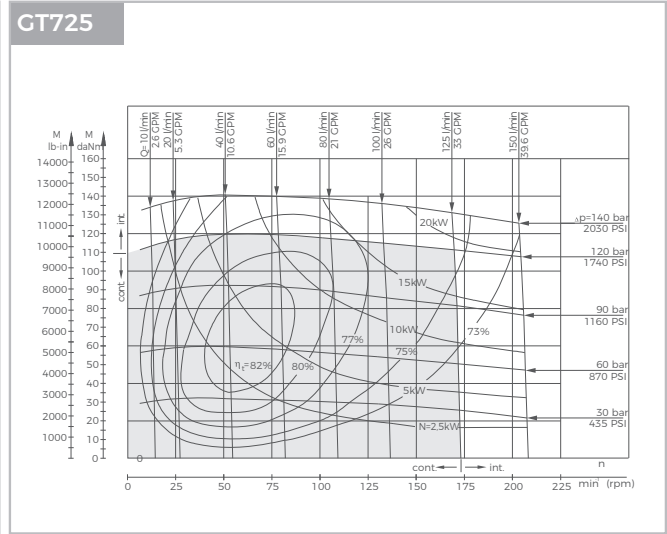
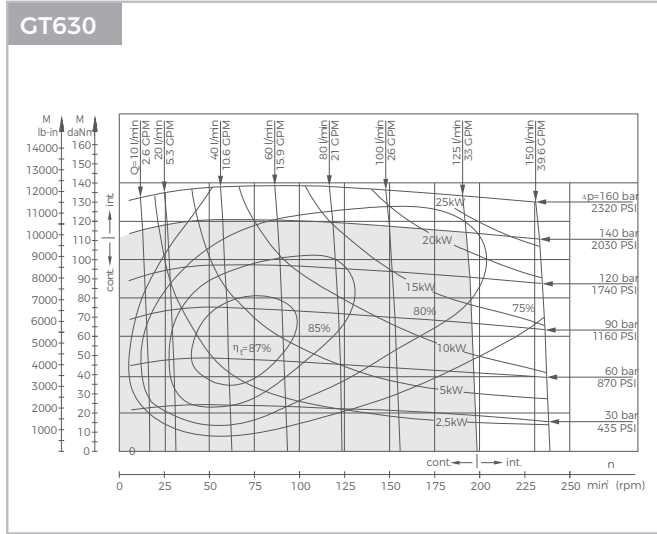

性能图是基于随机选出马达的平均参数，工况为背压0.5-1兆帕，粘度32mm²/s, 50℃。

GT 壳体 and 油口参数

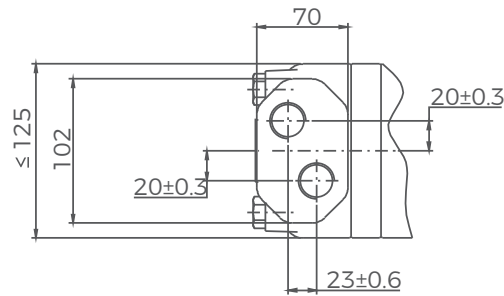
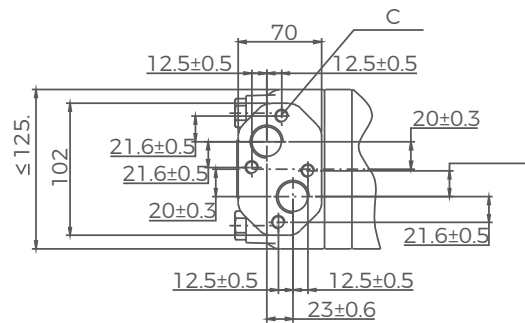
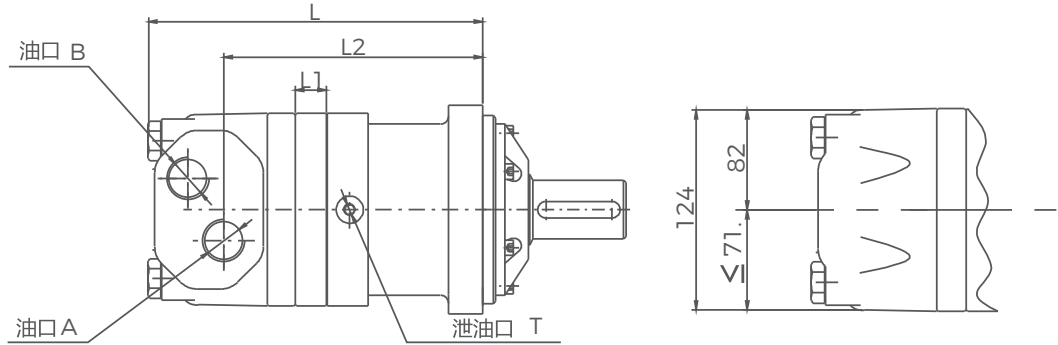

型号	L	L1	L2
GT160	193	17	142.5
GT200	197	21	146.5
GT250	204	14	152.5
GT315	210	20	158.5
GT400	217	27	165.5
GT500	225	35	173.5
GT630	237	47	185.5
GT725	248	58	196.5

代码 安装	代码	G3 (深度)	M5 (深度)	U4 (深度)	M9 (深度)	U5 (深度)
	P(A,B)	G3/4(18)	M27 x 2(18)	1-1/16-12UN(18)	M27 x 2(18)	1-1/16-12UN(18)
T	G1/4(12)	M14 x 1.5(12)	9/16-18UNF(12)	M14 x 1.5(12)	7/16-20UNF(12)	
C	4-M10(10)	4-M10(10)	—	—	—	

GT 前盖参数

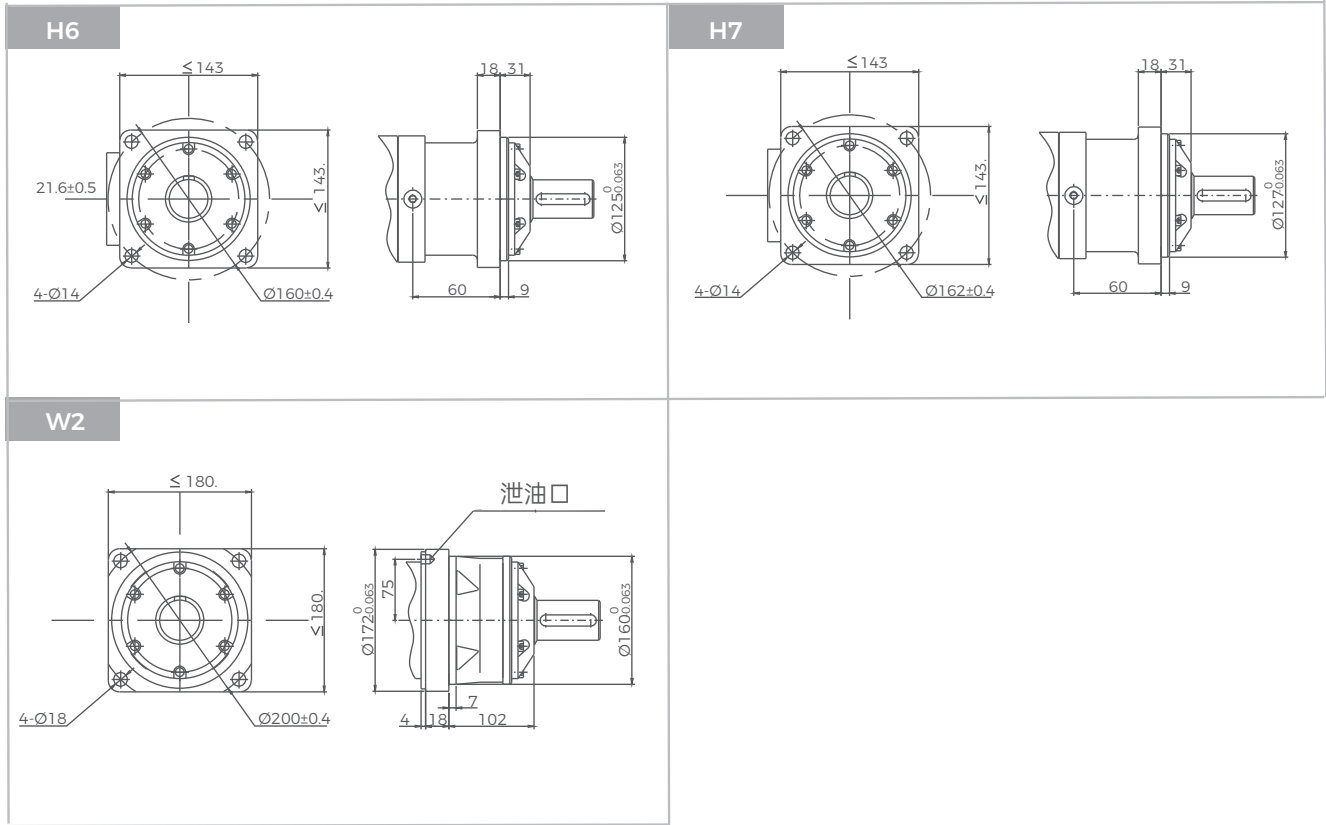

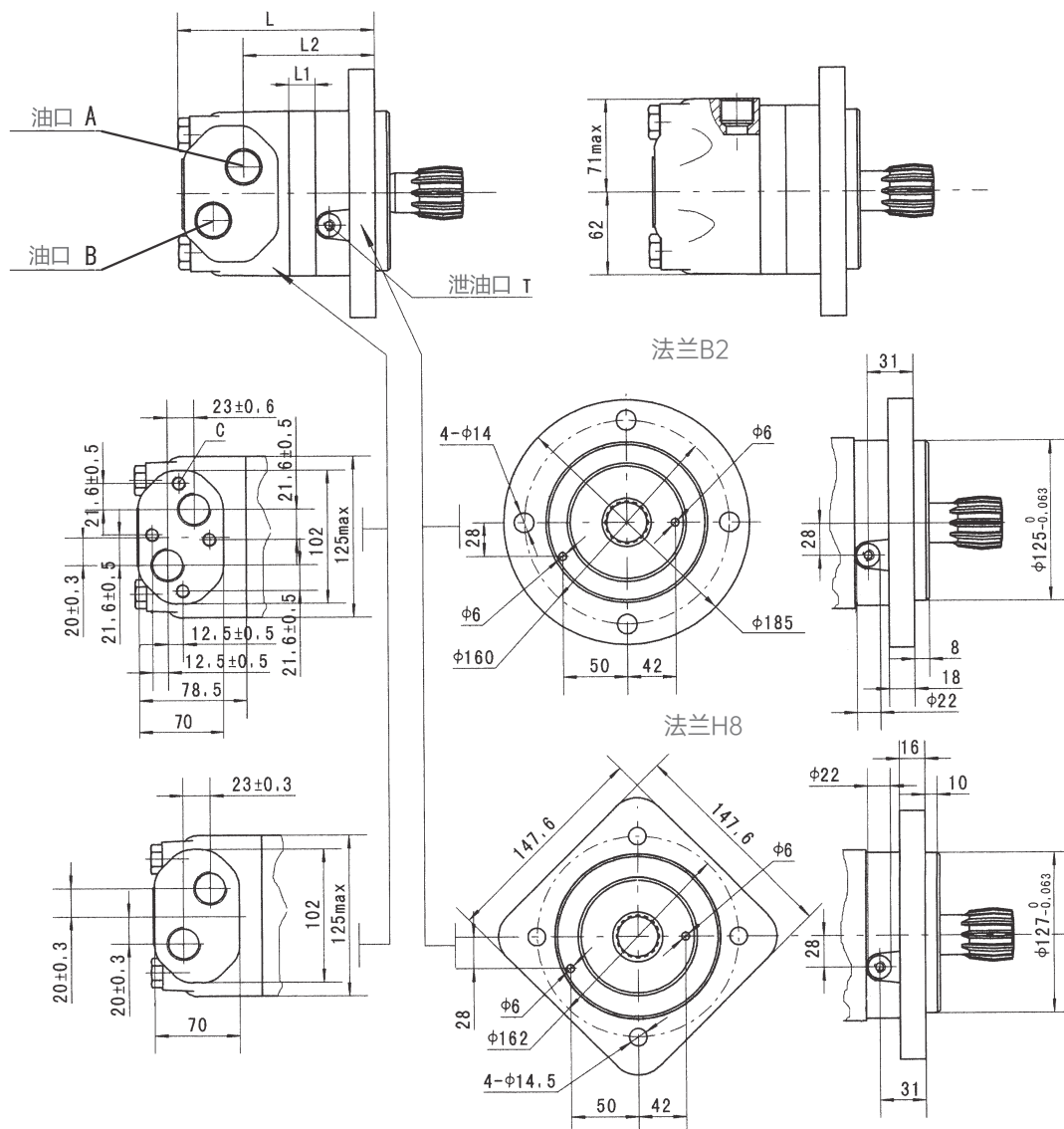
GTS 无轴承马达壳体 and 油口参数

型号	L	L1	L2
GTS160	148	17	96.5
GTS200	152	21	100.5
GTS250	157	14	109
GTS315	163	20	115
GTS400	170	27	122
GTS500	178	35	130
GTS630	190	47	142
GTS725	201	58	153

安装	代码				
	G3 (深度)	M5 (深度)	U4 (深度)	M9 (深度)	U5 (深度)
P(A,B)	G3/4(18)	M27x2(18)	1-1/16-12 UN(18)	M27x2(18)	1-1/16-12 UN(18)
T	G1/4(12)	M14x1.5(12)	9/16-18 UNF(12)	M14x1.5(12)	7/16-20 UNF(12)
C	4-M10(10)	4-M10(10)	—	—	—

GT 轴伸尺寸参数

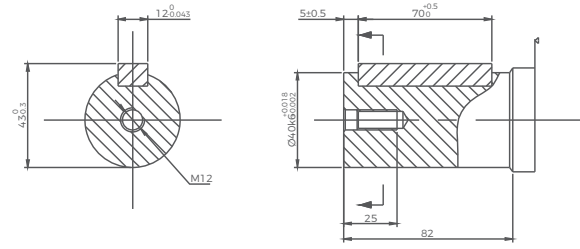
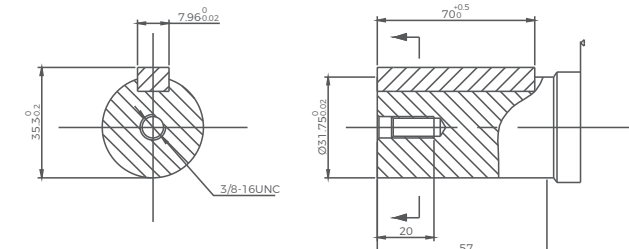
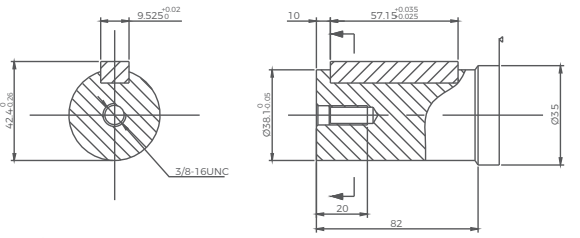
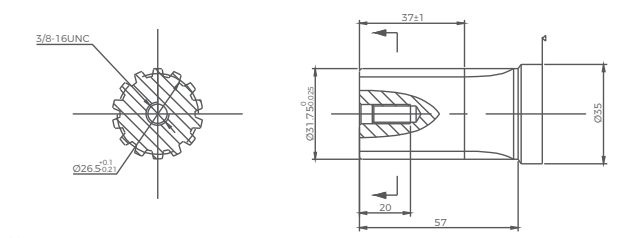
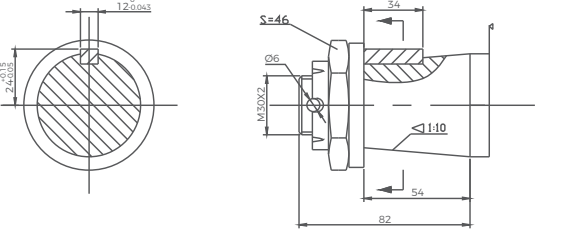
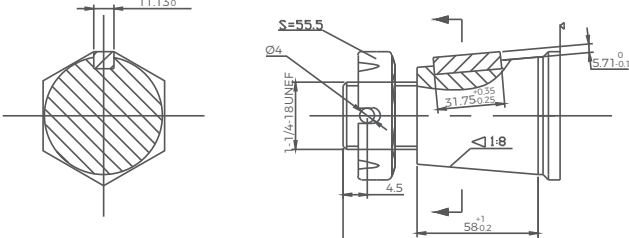
<p>SK</p>  <p>圆柱轴 Ø40 平键 12x8x70</p>	<p>SM</p>  <p>圆柱轴 Ø31.75 平键 7.96x7.96x40</p>
<p>SL</p>  <p>圆柱轴 Ø38.1 平键 9.525x9.525x57.15</p>	<p>R3</p>  <p>花键轴 14-DP 12/24</p>
<p>T6</p>  <p>锥轴 Ø45 平键 B12x8x28 螺母拧紧力矩: 500 ± 10 Nm</p>	<p>T7</p>  <p>锥轴 Ø45 平键 11.13x11.13x31.75 螺母拧紧力矩: 500 ± 10 Nm</p>

GT 轴伸尺寸参数

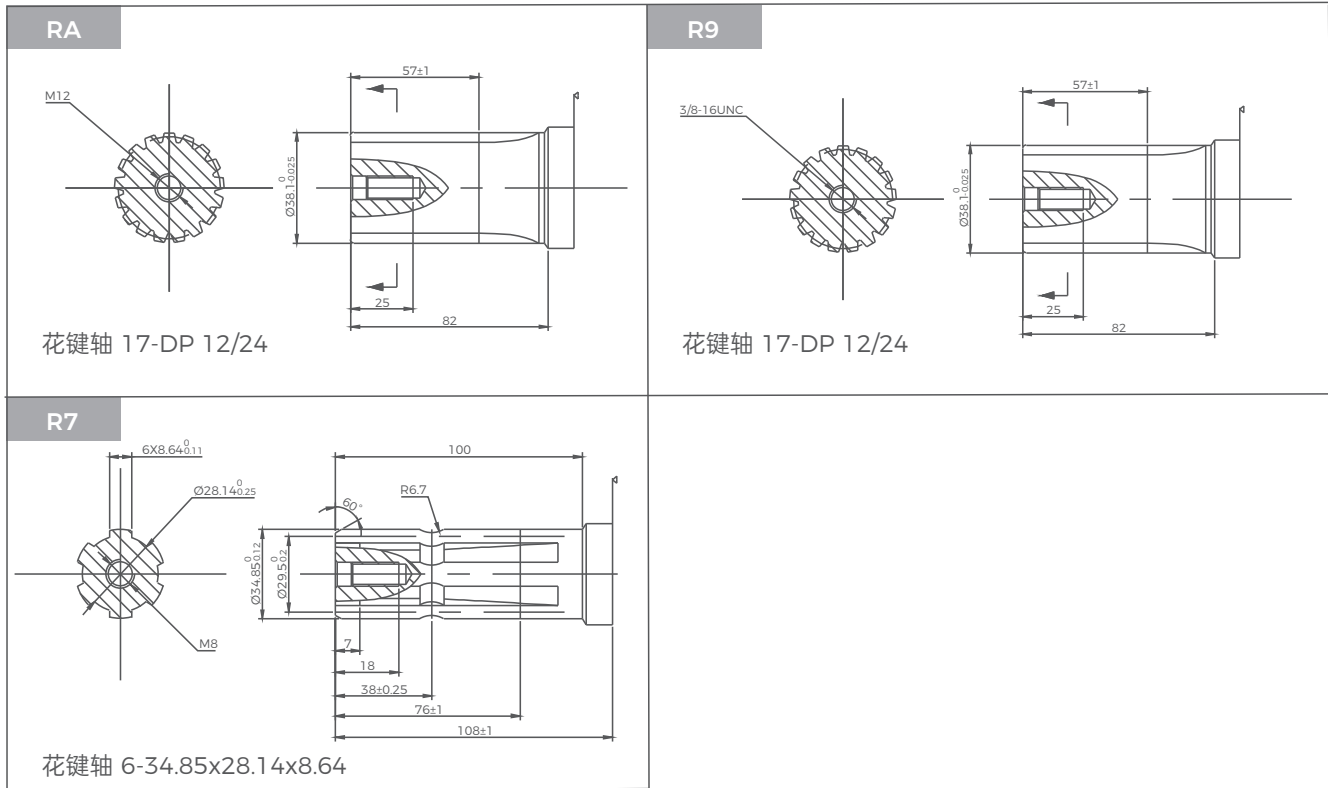

GT 摆线马达

输出轴密封圈允许承受的压力

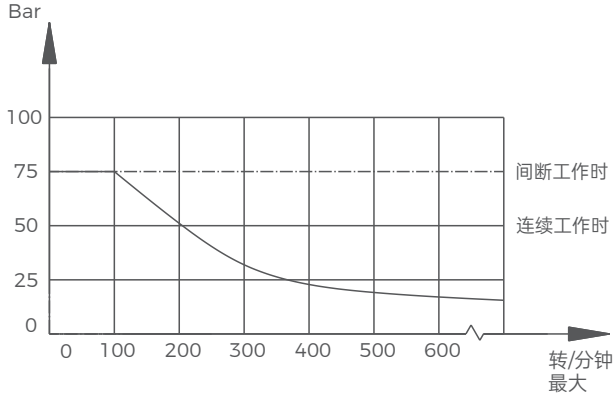

泄油口

在无外泄油管的使用中，输出轴密封圈上的压力微高于回油管路上的压力。当使用外泄油管时，输出轴密封圈上的压力则与外泄油管路中的压力相同。

轴旋转的标准方向：标准

当面对马达的轴端时，轴旋转：

当油口“A”增压时，顺时针方向旋转。

当油口“B”增压时，逆时针方向旋转。

轴向力和径向力

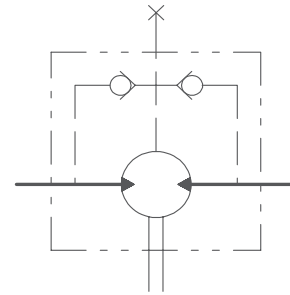
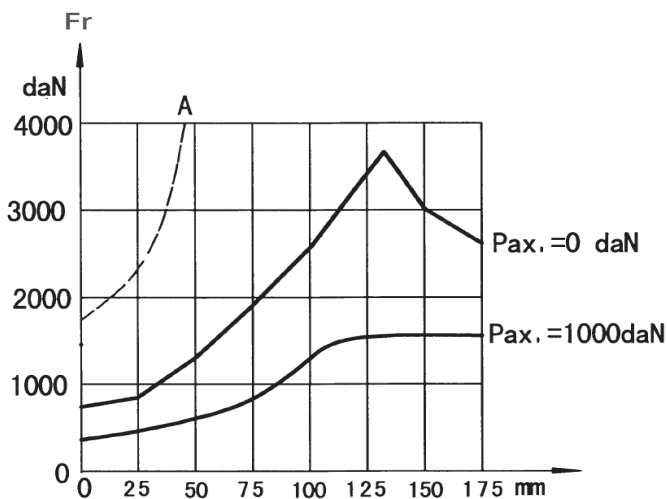

带有标准轴油封，单向阀且不使用泄油口连接的GT系列：轴上的压力永远不会超过回油管中的压力。

带有标准轴油封，单向阀和泄油口连接的GT系列：轴油封压力等于泄油管上的压力。

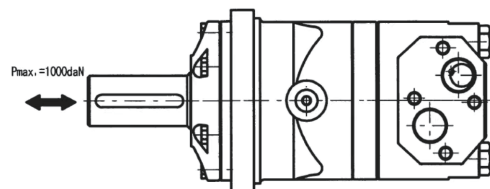
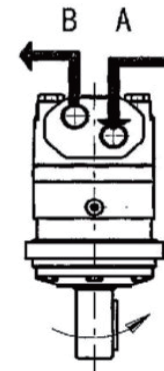

输出轴允许在高轴向力和径向力的圆锥轴承中运行，曲线“A”显示最大径向轴负载，任何超过该曲线中引用值的轴负载都将有断裂的危险，另外两条曲线适用于B10在200 RPM下的使用寿命为3000小时。