

Technical Information

Orbital Motors

GM / GP / GPH / GR / GRS / GH / GS / GT / GV

GFA / GGM / GKA / GKB / GKC / GWD / GBD





GUORUI HYDRAULICS

Keep the concept seeking excellence, GRH try our best to create more value for you with products and service.

Guorui Hydraulics

About GRH

GRH was established in 1986, focusing on providing customers with quality hydraulic components and solutions to hydraulic system in the applications of engineering machinery, mobile industries, agricultural machinery, aviation, mining, and other fields. Main products include gear pump, gear motor, flow divider, orbital motor, load sensing proportional valve, monoblock valve, sectional valve, manifold assembly and hydraulic power unit as well.

Long-term development strategy

Reducing emissions by new energy is one of GRH's long-term strategies. GRH will be providing innovative technologies, products, and services for the global development of new energy, moving towards a century development strategy, and writing a century-new chapter in the hydraulic field.



Innovation leads the future

Through a few decades of development, GRH has built an intelligent manufacturing factory, gathering international R&D talents, accumulating rich R&D and manufacturing experience, possessing independent intellectual property rights, continuously providing customers with new products and technologies, and creating value for all of the customers.

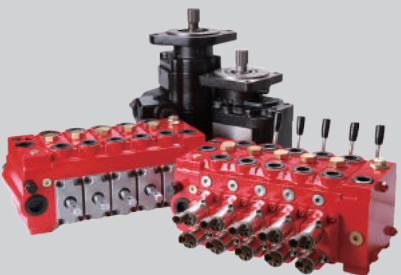

Orbital Motors

GM	GM Series Orbital Motors	05-12
	Speed 	2450 RPM
	Torque 	88 Nm
GP	GP Series Orbital Motors	13-26
	Speed 	1815 RPM
	Torque 	640 Nm
GPH	GPH Series Orbital Motors	27-39
	Speed 	1815 RPM
	Torque 	640 Nm
GR	GR Series Orbital Motors	40-49
	Speed 	970 RPM
	Torque 	690 Nm
GRS	GRS Series Orbital Motors	50-60
	Speed 	970 RPM
	Torque 	690 Nm
GH	GH Series Orbital Motors	61-68
	Speed 	445 RPM
	Torque 	1040 Nm
GS	GS Series Orbital Motors	69-80
	Speed 	1000 RPM
	Torque 	990 Nm
GT	GT Series Orbital Motors	81-92
	Speed 	775 RPM
	Torque 	1470 Nm

Orbital Motors

GV	GV Series Orbital Motors	93-101
	Speed	630 RPM
	Torque	2110 Nm
GFA	GFA Series Orbital Motors	102-112
	Speed	1141 RPM
	Torque	648 Nm
GGM	GGM Series Orbital Motors	113-120
	Speed	5000 RPM
	Torque	12.5 Nm
GKA	GKA Series Orbital Motors	121-128
	Speed	1215 RPM
	Torque	930 Nm
GKB	GKB Series Orbital Motors	129-137
	Speed	697 RPM
	Torque	1181 Nm
GKC	GKC Series Orbital Motors	138-143
	Speed	866 RPM
	Torque	1875 Nm
GWD	GWD Series Orbital Motors	144-150
	Speed	490 RPM
	Torque	1237 Nm
GBD	GBD Series Hydraulic Motor Brakes	151-153
	Speed	250 RPM
	Torque	1500 Nm

GM Series Hydraulic Motors

Options

- Flange connection
- Motor with needle roller bearing
- Side and rear ports
- Shaft seal for high and low pressure
- Straight, splined and tapered shafts
- Metric and BSPP ports
- Other special features

Applications

- Conveyors
- Feeding mechanism of robots and manipulators
- Metal working machines
- Textile machines
- Agricultural machines
- Food industries
- Lawn mower



General

Max. Displacement	cm ³ /rev [in ³ /rev]	50 [3.05]
Max. Speed	RPM	2440
Max. Torque	daNm [lb-in]	cont.: 4,5 [398] int.: 5,8 [513]
Max. Output	kW [HP]	3,2 [4.3]
Max. Pressure Drop	bar [PSI]	cont.: 105 [1500] int.: 140 [2030]
Max. Oil Flow	lpm [GPM]	25 [6.6]
Min. Speed	RPM	20
Pressure Fluid		Mineral based- HLP (DIN 51524) or HM (ISO 6743/4)
Temperature Range	°C [°F]	-40÷140 [-40÷284]
Optimal Viscosity Range	mm ² /s [SUS]	20÷75 [98÷347]
Filtration		ISO code: 20/16 (Min. recommended fluid filtration of 25 microns)

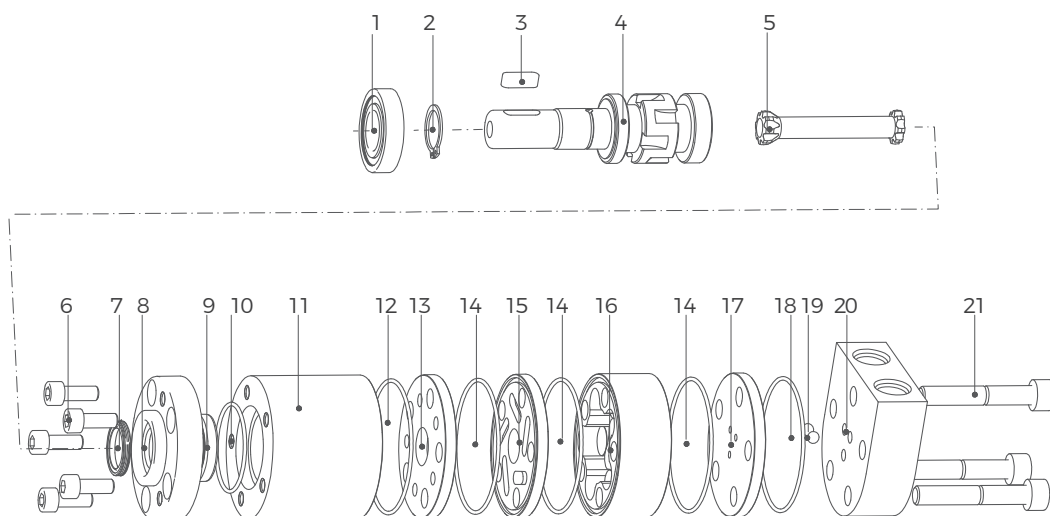

1 Tapered roller bearing
 2 Shaft retainer
 3 Paralled Key
 4 Output shaft

5 Transmission shaft
 6 Screw
 7 Anti-dust free ring
 8 Front Cover

9 Skeleton oil seal
 10 O-ring
 11 Housing
 12 O-ring

13 Spacer 1
 14 O-ring
 15 Spacer 2
 16 Rotor and stator

17 Balance plate
 18 O-ring seal
 19 Steel ball
 20 Rear cover
 21 Screw

Specifications

Type		GM8	GM12.5	GM20	GM32	GM40	GM50
Displacement, cm ³ /rev [in ³ /rev]		8.2[.50]	12.5[.77]	19.9[1.22]	31.6[1.93]	39.8[2.43]	50[3.08]
Max. Speed	Cont.	1950	1550	1000	630	500	400
RPM	Int.*	2450	1940	1250	800	630	500
Max. Torque	Cont.	1.1[95]	1.6[140]	2.5[220]	4.03501	4.5[400]	4.6[410]
daNm [lb-in]	Int.*	1.5[135]	2.3[200]	3.5[310]	5.7[500]	7.0[620]	8.8[780]
	Peak**	2.1[187]	3.3[293]	5.1[453]	6.4[568]	8.2[725]	10.0[885]
Max. Output	Cont.	1.8[2.4]	2.4[3.2]	2.4[3.2]	2.4[3.2]	2.2[3.0]	1.8[2.4]
kW [HP]	Int.*	2.6[3.5]	3.2[4.3]	3.2[4.3]	3.2[4.3]	3.2[4.3]	3.2[4.3]
Max. Pressure Drop	Cont.	100[1450]	100[1450]	100[1450]	100[1450]	90[1310]	70[1020]
bar [PSI]	Int.*	140[2030]	140[2030]	140[2030]	140[2030]	140[2030]	140[2030]
	Peak**	200[2900]	200[2900]	200[2900]	160[2900]	160[2900]	160[2900]
Max. Oil Flow	Cont.	16[4.2]	20[5.3]	20[5.3]	20[5.3]	20[5.3]	20[5.3]
lpm [GPM]	Int.*	20[5.3]	25[6.6]	25[6.6]	25[6.6]	25[6.6]	25[6.6]
Max. Inlet Pressure	Cont.	140[2030]	140[2030]	140[2030]	140[2030]	140[2030]	140[2030]
bar [PSI]	Int.*	175[2540]	175[2540]	175[2540]	175[2540]	175[2540]	175[2540]
	Peak**	225[3260]	225[3260]	225[3260]	225[3260]	225[3260]	225[3260]
Max. Return Pressure	Cont. 0-100 RPM	140[2030]	140[2030]	140[2030]	140[2030]	140[2030]	140[2030]
without Drain Line	Cont.100-400 RPM	105[1500]	105[1500]	105[1500]	105[1500]	105[1500]	105[1500]
bar [PSI]	Cont. 400-800 RPM	50[725]	50[725]	50[725]	50[725]	50[725]	50[725]
Max. Pressure	Cont. >800 RPM	20[290]	20[290]	20[290]	-	-	-
in Drain Line, bar [PSI]	int.* 0-max. RPM	140[2030]	140[2030]	140[2030]	140[2030]	140[2030]	140[2030]
Max. Return Pressure	Cont.	140[2030]	140[2030]	140[2030]	140[2030]	140[2030]	140[2030]
with Drain Line	Int.*	175[2540]	175[2540]	175[2540]	175[2540]	175[2540]	175[2540]
bar [PSI]	Peak**	225[3260]	225[3260]	225[3260]	225[3260]	225[3260]	225[3260]
Max. Starting Pressure with Unloaded Shaft, bar [PSI]		4[60]	4[60]	4[60]	4[60]	4[60]	4[60]
Min. Starting Torque	At max. press. drop Cont.	0.7[60]	1.2[105]	2.1[185]	3.4[300]	3.8[335]	4.1[365]
daNm [lb-in]	At max. press. drop Int.*	1.0[90]	1.7[150]	2.9[255]	4.8[425]	6.2[550]	7.9[700]
Min. Speed***, RPM		50	40	30	30	25	20
Weight, kg [lb] For "F" flange: +0,200 [441]	GM	1.9[4.2]	2.0[4.41]	2.1[4.63]	2.2[4.85]	2.3[5.07]	2.5[5.51]

Function Diagrams

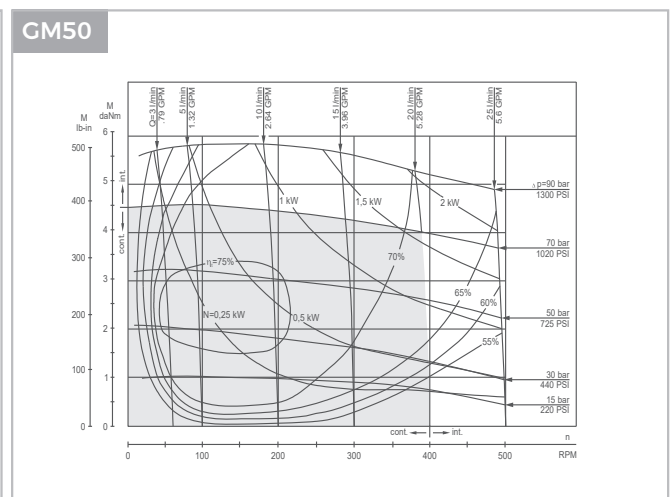
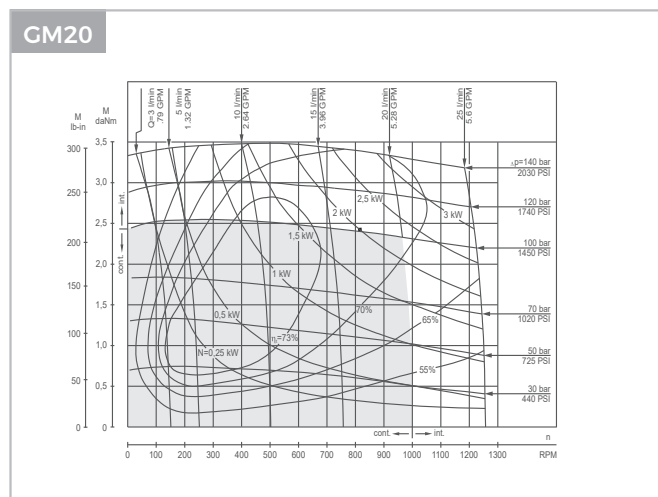
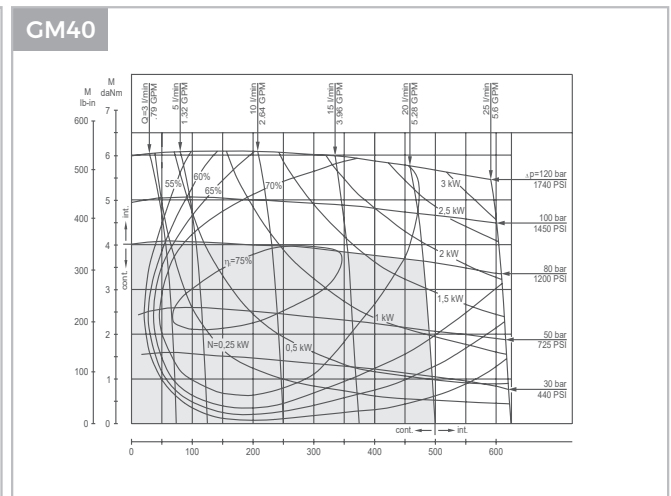
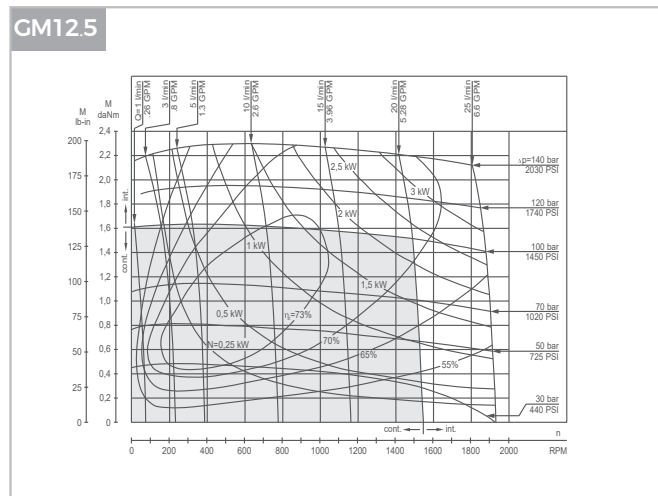
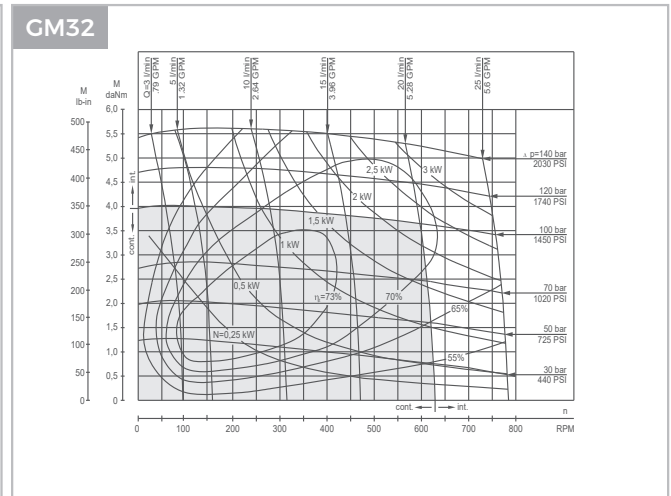
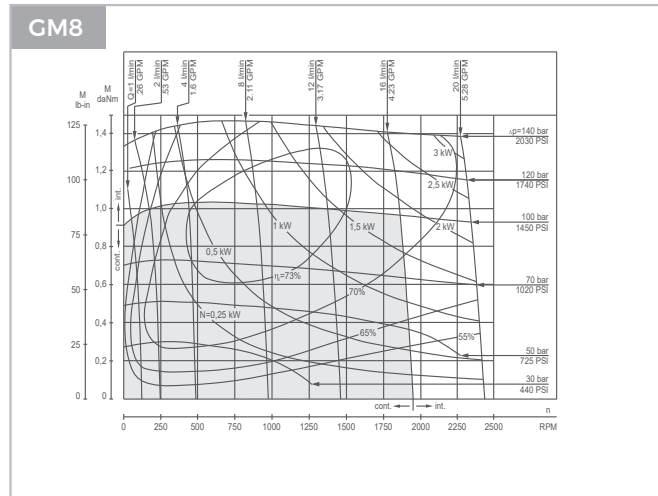

The function diagrams data is for average performance of randomly selected motors at backpressure. 5÷10 bar [72.5÷145 PSI] and oil with viscosity of 32 mm²/s [150 SUS] at 50°C [122 F].

GM Dimensions and Mountings

Model A

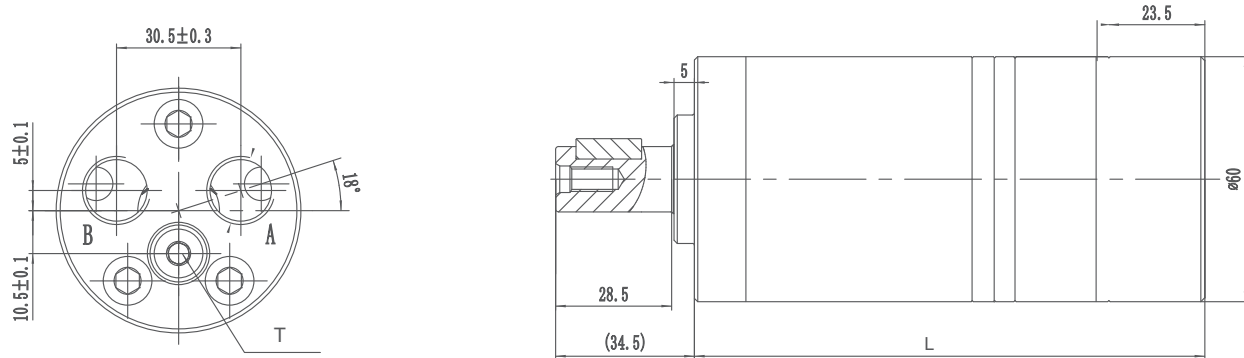

Model B

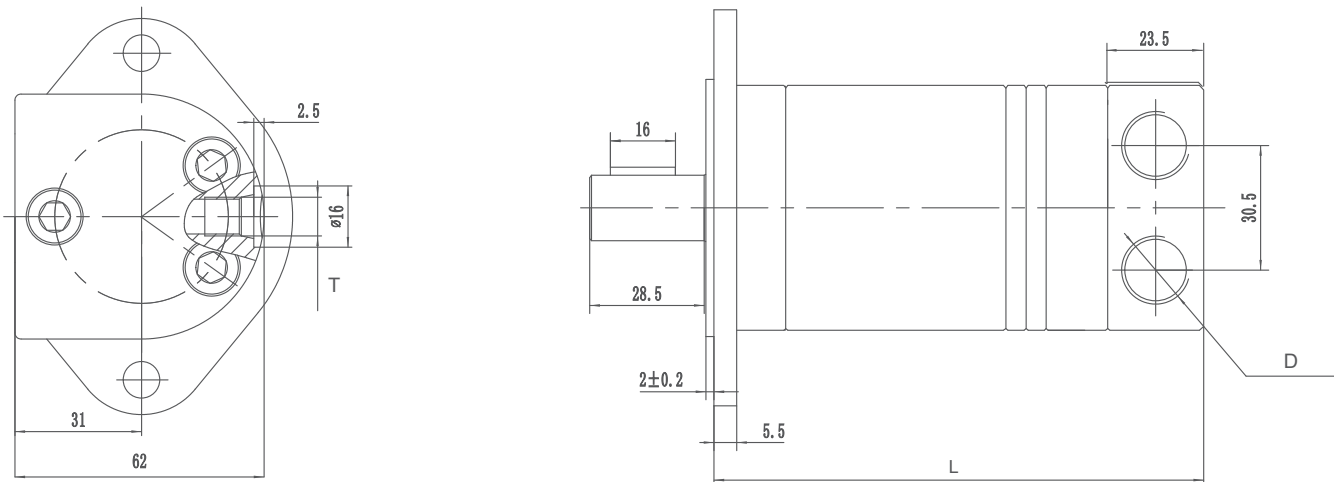

Model	Model A	Model B
	L	L
GM8	109	105
GM12.5	111	107
GM20	114	110
GM32	119	115
GM40	122	118
GM50	127	123

Mounting	GA	U8	GB	U9
	(depth)	(depth)	(depth)	(depth)
P(A, B)	G3/8 (12)	9/16-18UNF (12)	End port G3/8 (12)	End port 9/16-18UNF (12)
T	G1/8 (8)	3/8-24UNF (8)	G1/8 (8)	8-24UNF (8)

GM Flange Covers Dimensions

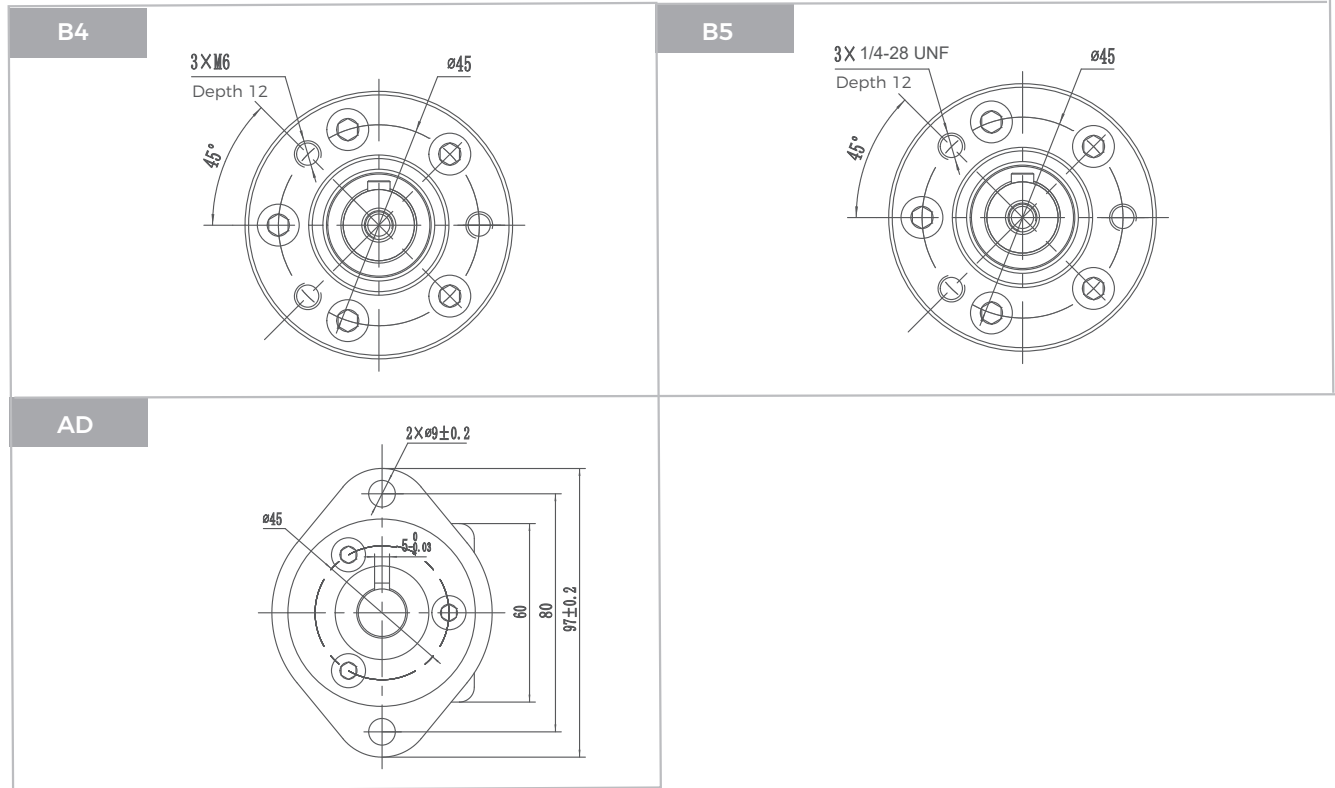

GM Shafts Dimensions

SS

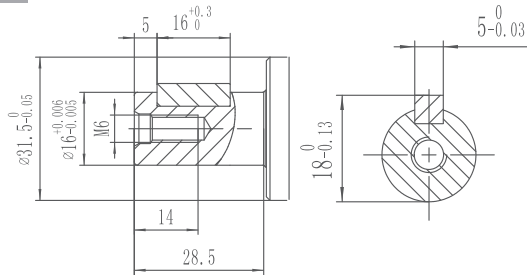

Straight shaft Ø16
Parallel key 5 x 5 x 16

ST

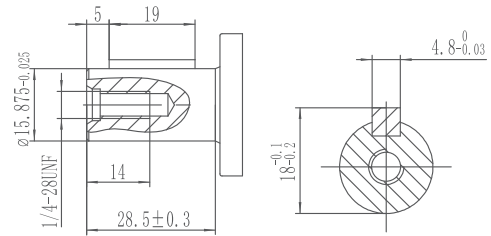

Straight shaft Ø15.875
Parallel key 4.8 x 4.8 x 19.05

RK

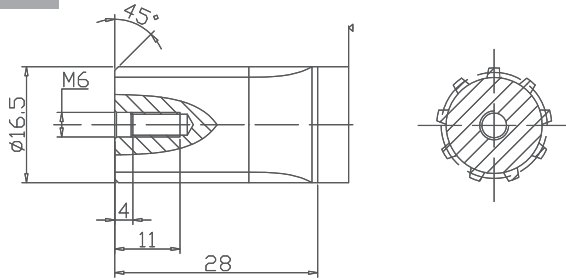

Splined shaft Ø16.5
B7 x 14 DIN5482

GM Series Hydraulic Motors

Permissible shaft seal pressure

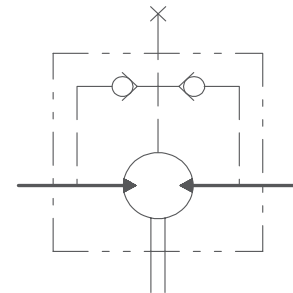
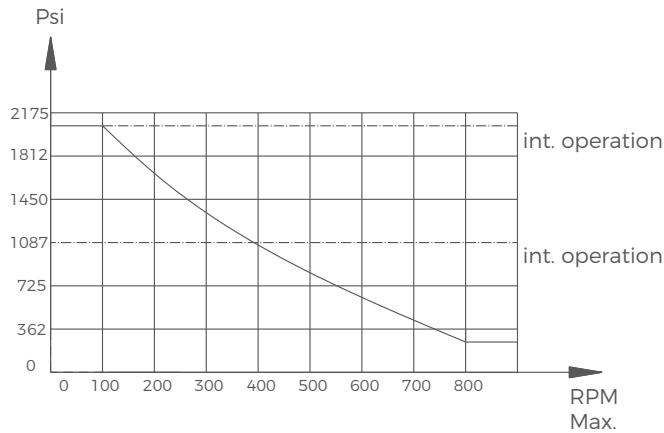

GM with standard shaft seal check valves and without use of drain connection: The pressure on the shaft seal never exceeds the pressure in the return line. GM with standard shaft seal, check valves and with drain connection: The shaft seal pressure equals the pressure on the drain line.

Drain Port

In applications without drain line, output shaft seal exceeds a bit of the pressure in the return line. In applications using the drain line, the pressure of output shaft seal equals the pressure in drain line.

Standard direction of shaft rotation: Standard

When facing shaft end of motor, shaft to rotate:
Clockwise. When port "A" is pressurized.
Counter-clockwise port "B" is pressurized.

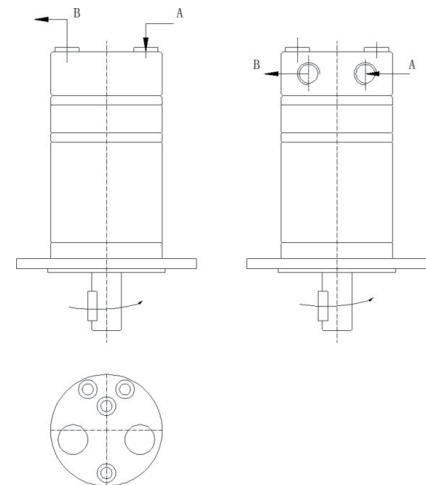

Axial and Radial force

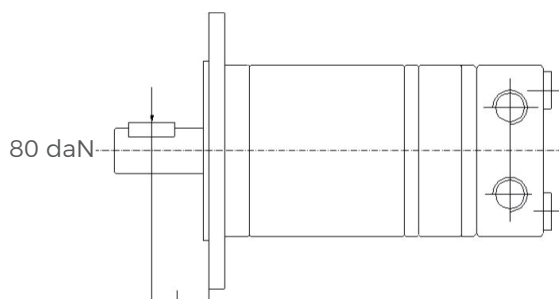

$$Fr = \frac{600}{n} * \frac{13040}{61.5 + L} \text{ (daN)}$$

Fr =Radial Force (daN)

L =Distance (mm)

n =Speed (rpm)

Rhomb flange L=15mm

Square flange L=20mm

GP Series Hydraulic Motors

Options

- Flange connection
- Motor with needle roller bearing
- Side and rear ports
- Shaft seal for high and low pressure
- Straight, splined and tapered shafts
- Metric and BSPP ports
- Other special features

Applications

- Conveyors
- Feeding mechanism of robots and manipulators
- Metal working machines
- Textile machines
- Agricultural machines
- Food industries
- Lawn mower







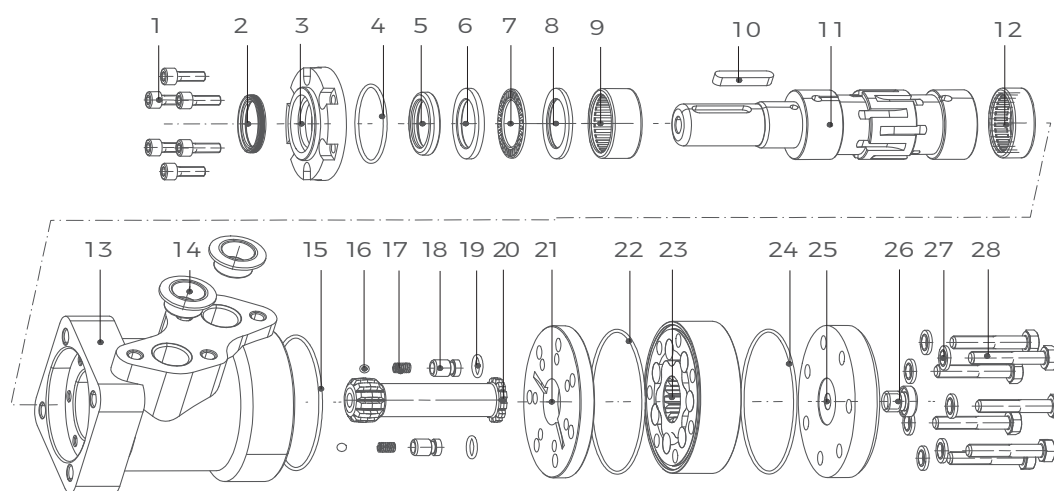



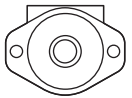
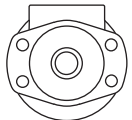
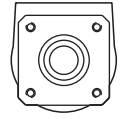

General

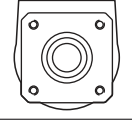
Max. Displacement	cm ³ /rev [in ³ /rev]	623.6 [38.05]
Max. Speed	RPM	1815
Max. Torque	daNm [lb-in]	cont.: 50 [5144] int.: 64 [5565]
Max. Output	kW [HP]	12.8 [17.1]
Max. Pressure Drop	bar [PSI]	cont.:140 [2030] int.:175 [2540]
Max. Oil Flow	lpm [GPM]	75 [19.8]
Min. Speed	RPM	10
Pressure Fluid		Mineral based- HLP [DIN 51524] or HM [ISO 6743/4]
Temperature Range	°C [°F]	-40÷140 [-40÷284]
Optimal Viscosity range	mm ² /s [SUS]	20÷75 [98÷347]
Filtration		ISO code 20/16 [Min. recommended fluid filtration of 25 microns]



1 Bolt	6 Bearing retainer	11 Output shaft	16 Steel ball	21 Spacer	26 Plug
2 Anti-dust ring	7 Flat bearing	12 Needle roller bearing	17 Spring	22 O-ring seal	27 Washer
3 Front cover	8 Bearing retainer	13 Housing	18 Check valve	23 Rotor and stator	28 Screw
4 O-ring seal	9 Needle roller bearing	14 Rubber plug	19 O-ring seal	24 O-ring seal	
5 Shaft seal	10 Parallel key	15 O-ring seal	20 Transmission shaft	25 Rear cover	

Ordering Code

GP SERIES	DISP	FLANGE	SHAFT	PORTS	ROTATION	PAINT	FUNCTION
CODE	DISP	CODE	FLANGE	CODE	PORTS	CODE	PAINT
025	25cm ³ /rev [1.52in ³ /rev]	A2	2-Hole SAE A, pilot Ø82.5×2.8 	G1	G1/2, G1/4 manifold 4×M8	A	No Paint
032	32cm ³ /rev [1.95in ³ /rev]			M1	M22×1.5M14×1.5, manifold 4×M8	B	Blue
040	40cm ³ /rev [2.44in ³ /rev]			U2	7/8-1UNF, 7/16-20UN manifold 4×5/16-18UNCF	C	Black
050	49.5cm ³ /rev [3.02in ³ /rev]	A4	4-Hole SAE A, pilot Ø82.5×2.8 	U1	7/8-14NPTF, 7/16 - 20UNF, manifold 4×5/16 - 18UNC	S	Silver grey
080	79.2cm ³ /rev [4.83in ³ /rev]			G2	PT (Rc) 1/2, PT (Rc) 1/4 manifold 4×M8		
100	99cm ³ /rev [6.04in ³ /rev]						
125	123.8cm ³ /rev [7.55in ³ /rev]	H4	4-3/8-16UNC square, pilot Ø44.4×2.8 	CODE	SHAFT	CODE	FUNCTION
160	158.4cm ³ /rev [9.66in ³ /rev]			S1	Shaft Ø25, parallel key 8×7×32 	A	Standard
200	198cm ³ /rev [12.1in ³ /rev]			S2	Shaft Ø25.4, parallel key 6.35×6.35×31.75 	N	Big radial force
250	247.5cm ³ /rev [15.1in ³ /rev]	H5	4-M10 square, pilot Ø44.4×2.8 	R1	Shaft Ø25.4, splined tooth SAE6B 	D	No case drain
315	316.8cm ³ /rev [19.3in ³ /rev]			S3	Shaft Ø25.4, parallel key 6.35×6.35×31.75 	F	Free running
400	396cm ³ /rev [24.16in ³ /rev]			S4	Shaft Ø32, parallel key 10×8×45 	L	Low speed
500	495cm ³ /rev [30.2in ³ /rev]			S5	Shaft Ø31.75, parallel key 7.96×7.96×31.75 	V	High temp.
630	623.6cm ³ /rev [38.05in ³ /rev]			T1	Tapered shaft Ø28.56, parallel key B5×5×14 	S	Low temp.
				R2	Shaft Ø31.75, splined tooth 14 - DP 12/24 	CODE	ROTATION
				R3	Long shaft Ø31.75,splined tooth 14 - DP 12/24 	A	Standard
				T2	Tapered shaft Ø31.75, paralle key 7.96×7.96×25.4 	R	Opposite

Specifications

Technical data for GP with Ø25 and 1" straight and 1" splined and Ø28.56 tapered shaft

Type		GP25	GP32	GP40	GP50	GP80	GP100	GP125
Displacement, cm ³ /rev [in ³ /rev]		25[1.52]	32[1.95]	40[2.44]	49.5[3.02]	79.2[4.83]	99[6.04]	123.8[7.55]
Max. Speed,	Cont.	1600	1560	1500	1210	755	605	486
RPM	Int*	1815	1720	1750	1515	945	755	605
Max. Torque	Cont.	3.3[290]	4.3[380]	6.2[550]	9.4[835]	15.1[1340]	19.3[1710]	23.7[2100]
daNm [lb-in]	Int*	4.7[415]	6.1[540]	8.2[730]	11.9[1050]	19.5[1725]	23.7[2100]	29.8[2640]
	Peak**	6.7[595]	8.6[760]	10.7[950]	14.3[1285]	22.4[1985]	27.5[2435]	36.5[3235]
Max. Output	Cont.	4.5[6.0]	5.8[7.8]	8.4[11.5]	10.1[13.5]	10.2[13.7]	10.5[14.1]	10.2[13.7]
kW [HP]	Int*	6.1[8.2]	7.8[10.5]	11.6[15.5]	12.2[16.1]	12.5[16.8]	12.8[17.1]	12[16.1]
Max. Pressure Drop	Cont.	100[1450]	100[1450]	120[1750]	140[2030]	140[2030]	140[2030]	140[2030]
bar [PSI]	Int*	140[2030]	140[2030]	155[2250]	175[2540]	175[2540]	175[2540]	175[2540]
	Peak**	225[3260]	225[3260]	225[3260]	225[3260]	225[3260]	225[3260]	225[3260]
Max. Oil Flow	Cont.	40[10.5]	50[13.2]	60[15.9]	60[15.9]	60[15.9]	60[15.9]	60[15.9]
lpm [GPM]	Int*	45[11.9]	55[14.5]	70[18.5]	75[19.8]	75[19.8]	75[19.8]	75[19.8]
Max. Inlet Pressure	Cont.	175[2540]	175[2540]	175[2540]	175[2540]	175[2540]	175[2540]	175[2540]
bar [PSI]	Int*	200[2900]	200[2900]	200[2900]	200[2900]	200[2900]	200[2900]	200[2900]
	Peak**	225[3260]	225[3260]	225[3260]	225[3260]	225[3260]	225[3260]	225[3260]
Max. Return Pressure	Cont.	175[2540]	175[2540]	175[2540]	175[2540]	175[2540]	175[2540]	175[2540]
without Drain Line	Int*	200[2900]	200[2900]	200[2900]	200[2900]	200[2900]	200[2900]	200[2900]
bar [PSI]	Peak**	225[3260]	225[3260]	225[3260]	225[3260]	225[3260]	225[3260]	225[3260]
Max. Starting Pressure		10[145]	10[145]	10[145]	10[145]	10[145]	10[145]	9[131]
with Unloaded Shaft, bar [PSI]								
Min. Starting Torque	At max. press. drop Cont.	3.0[265]	4.0[355]	5.4[480]	7.8[690]	13.2[1170]	16.6[1470]	20.7[1830]
daNm [lb-in]	At max. press. drop Int*	4.2[370]	5.6[500]	6.8[600]	10[885]	16.8[1490]	21[1860]	26.6[2360]
Min. Speed***, RPM		20	15	10	10	10	10	10
Weight, kg [lb] For								
Rear Port + 0.450 [992]	GP	5.6[12.3]	5.6[12.3]	5.7[12.6]	5.8[12.8]	5.9[13.2]	6.1[13.5]	6.2[13.7]

Specifications

Technical data for GP with $\varnothing 25$ and 1" straight and 1" splined and $\varnothing 28.56$ tapered shaft

Type		GP160	GP200	GP250	GP315	GP400	GP500	GP630
Displacement, cm ³ /rev [in ³ /rev]		158,4[9.66]	198[12.1]	247,5[15.1]	316,8[19.3]	396[24.16]	495[30.2]	623,6[38.05]
Max. Speed,	Cont	378	303	242	190	150	120	95
RPM	Int*	472	378	303	236	189	150	120
Max. Torque	Cont	31,3[2770]	36,6[3240]	38[3360]	38[3360]	36[3190]	39[3452]	44[3895]
daNm [lb-in]	Int*	37,8[3345]	45,6[4035]	58,3[5160]	56[4960]	59[5240]	57[5045]	64[5665]
	Peak**	43,8[3880]	55[4870]	68,5[6060]	85[7505]	85,4[7560]	78[6903]	82[7257]
Max. Output	Cont	10,1[13.5]	10[13.5]	7,5[10]	5,8[7.9]	4,6[6.2]	3,5[4.7]	3,3[4.4]
kW [HP]	Int*	12,1[16.2]	12[16.1]	12[16.1]	9[12.1]	7,8[10.5]	7,2[9.7]	5,6[7.5]
Max. Pressure Drop	Cont	140[2030]	140[2030]	110[1600]	90[1300]	70[1015]	60[870]	55[800]
bar [PSI]	Int*	175[2540]	175[2540]	175[2540]	140[2030]	115[1665]	90[1305]	80[1160]
	Peak**	225[3260]	225[3260]	225[3260]	225[3260]	180[2610]	130[1885]	110[1740]
Max. Oil Flow	Cont	60[15.9]	60[15.9]	60[15.9]	60[15.9]	60[15.9]	60[15.9]	60[15.9]
lpm [GPM]	Int*	75[19.8]	75[19.8]	75[19.8]	75[19.8]	75[19.8]	75[19.8]	75[19.8]
Max. Inlet Pressure	Cont	175[2540]	175[2540]	175[2540]	175[2540]	175[2540]	140[2030]	140[2030]
bar [PSI]	Int*	200[2900]	200[2900]	200[2900]	200[2900]	200[2900]	175[2540]	175[2540]
	Peak**	225[3260]	225[3260]	225[3260]	225[3260]	225[3260]	225[3260]	225[3260]
Max. Return Pressure	Cont	175[2540]	175[2540]	175[2540]	175[2540]	175[2540]	140[2030]	140[2030]
without Drain Line	Int*	200[2900]	200[2900]	200[2900]	200[2900]	200[2900]	175[2540]	175 [2540]
bar [PSI]	Peak**	225[3260]	225[3260]	225[3260]	225[3260]	225[3260]	225[3260]	225[3260]
Max. Starting Pressure		8[116]	7[100]	6[87]	5[73]	5[73]	5[73]	5[73]
with Unloaded Shaft, bar [PSI]								
Min. Starting Torque	At max. press. drop Cont	28,2[2500]	33,5[2950]	33,6[2970]	34,4[3045]	34,5[3050]	36[3180]	41,5[3670]
daNm [lb-in]	At max. press. drop Int*	35,5[3140]	42,6[3770]	54,2[4795]	61,9[5480]	60,8[5390]	54[4780]	62[5480]
Min. Speed***, RPM		10	10	10	10	10	10	10
Weight, kg [lb] For								
Rear Port + 0.450 [992]	GP	6,4[14.1]	6,6[14.6]	6,8[15]	7,1[15.6]	7,6[16.8]	8,9[20]	9,5[21.4]

Specifications

Technical data for GP with $\varnothing 31.75$ and $\varnothing 32$ shaft

Type		GP25	GP32	GP40	GP50	GP80	GP100	GP125
Displacement, cm ³ /rev [in ³ /rev]		25[1.52]	32[1.95]	40[2.44]	49.5[3.02]	79.2[4.83]	99[6.04]	123.8[7.55]
Max. Speed,	Cont	1600	1560	1500	1210	755	605	486
RPM	Int*	1815	1720	1750	1515	945	755	605
Max. Torque	Cont	3.3[290]	4.3[380]	6.2[550]	9.4[835]	15.1[1340]	19.3[1710]	23.7[2100]
daNm [lb-in]	Int*	4.7[415]	6.1[540]	8.2[730]	11.9[1050]	19.5[1725]	23.7[2100]	29.8[2640]
	Peak**	6.7[595]	8.6[760]	10.7[950]	14.3[1285]	22.4[1985]	27.5[2435]	36.5[3235]
Max. Output	Cont	4.5[6.0]	5.8[7.8]	8.4[11.5]	10.1[13.5]	10.2[13.7]	10.5[14.1]	10.2[13.7]
kW [HP]	Int*	6.1[8.2]	7.8[10.5]	11.6[15.5]	12.2[16.1]	12.5[16.8]	12.8[17.1]	12[16.1]
Max. Pressure Drop	Cont	100[1450]	100[1450]	120[1750]	140[2030]	140[2030]	140[2030]	140[2030]
bar [PSI]	Int*	140[2030]	140[2030]	155[2250]	175[2540]	175[2540]	175[2540]	175[2540]
	Peak**	225[3260]	225[3260]	225[3260]	225[3260]	225[3260]	225[3260]	225[3260]
Max. Oil Flow	Cont	40[10.5]	60[13.2]	60[15.9]	60[15.9]	60[15.9]	60[15.9]	60[15.9]
lpm [GPM]	Int*	45[11.9]	55[14.5]	70[18.5]	75[19.8]	75[19.8]	75[19.8]	75[19.8]
Max. Inlet Pressure	Cont	175[2540]	175[2540]	175[2540]	175[2540]	175[2540]	175[2540]	175[2540]
bar [PSI]	Int*	200[2900]	200[2900]	200[2900]	200[2900]	200[2900]	200[2900]	200[2900]
	Peak**	225[3260]	225[3260]	225[3260]	225[3260]	225[3260]	225[3260]	225[3260]
Max. Return Pressure	Cont	175[2540]	175[2540]	175[2540]	175[2540]	175[2540]	175[2540]	175[2540]
without Drain Line	Int*	200[2900]	200[2900]	200[2900]	200[2900]	200[2900]	200[2900]	200[2900]
bar [PSI]	Peak**	225[3260]	225[3260]	225[3260]	225[3260]	225[3260]	225[3260]	225[3260]
Max. Starting Pressure		10[145]	10[145]	10[145]	10[145]	10[145]	10[145]	9[131]
with Unloaded Shaft, bar [PSI]								
Min. Starting Torque		3.0[265]	4.0[355]	5.4[480]	7.8[690]	13.2[1170]	16.6[1470]	20.7[1830]
daNm [lb-in]	At max. press. drop Cont	4.2[370]	5.6[500]	6.8[600]	10[885]	16.8[1490]	21[1860]	26.6[2360]
Min. Speed***, RPM	At max. press. drop Int*	20	15	10	10	10	10	10
Weight, kg [lb] For Rear Port + 0.450 [992]	GP	5.6[12.3]	5.6[12.3]	5.7[12.6]	5.9[13]	6[13.2]	6.2[13.7]	6.3[13.9]

Specifications

Technical data for GP with $\varnothing 31.75$ and $\varnothing 32$ shaft

Type		GP160	GP200	GP250	GP315	GP400	GP500	GP630
Displacement, cm ³ /rev [in ³ /rev]		158,4[9.66]	198[12.1]	247,5[15.1]	316,8[19.3]	396[24.16]	495[30.2]	623,6[38.05]
Max. Speed,	Cont.	378	303	242	190	150	120	95
RPM	Int.*	472	378	303	236	189	150	120
Max. Torque	Cont.	31,3[2770]	36,6[3240]	47[4160]	48[4360]	50[4415]	39[3452]	44[3895]
daNm [lb-in]	Int.*	37,8[3345]	45,6[4035]	58,3[5160]	56[4960]	59[5240]	57[5045]	64[5665]
	Peak**	43,8[3880]	55[4870]	68,5[6060]	85[7505]	85,4[7560]	78[6903]	82[7257]
Max. Output	Cont.	10,1[13.5]	10[13.5]	9[12.1]	7,6[10.2]	6,2[8.3]	3,5[4.7]	3,3[4.4]
kW [HP]	Int.*	12,1[16.2]	12[16.1]	12[16.1]	9[12.1]	7,8[10.5]	7,2[9.7]	5,6[7.5]
Max. Pressure Drop	Cont.	140[2030]	140[2030]	140[2030]	120[1740]	95[1400]	60[870]	55[800]
bar [PSI]	Int.*	175[2540]	175[2540]	175[2540]	140[2030]	115[1670]	90[1305]	80[1160]
	Peak**	225[3260]	225[3260]	225[3260]	225[3260]	180[2610]	130[1885]	110[1740]
Max. Oil Flow	Cont.	60[15.9]	60[15.9]	60[15.9]	60[15.9]	60[15.9]	60[15.9]	60[15.9]
lpm [GPM]	Int.*	75[19.8]	75[19.8]	75[19.8]	75[19.8]	75[19.8]	75[19.8]	75[19.8]
Max. Inlet Pressure	Cont.	175[2540]	175[2540]	175[2540]	175[2540]	175[2540]	140[2030]	140[2030]
bar [PSI]	Int.*	200[2900]	200[2900]	200[2900]	200[2900]	200[2900]	175[2540]	175[2540]
	Peak**	225[3260]	225[3260]	225[3260]	225[3260]	225[3260]	225[3260]	225[3260]
Max. Return Pressure	Cont.	175[2540]	175[2540]	175[2540]	175[2540]	175[2540]	140[2030]	140[2030]
without Drain Line	Int.*	200[2900]	200[2900]	200[2900]	200[2900]	200[2900]	175[2540]	175[2540]
bar [PSI]	Peak**	225[3260]	225[3260]	225[3260]	225[3260]	225[3260]	225[3260]	225[3260]
Max. Starting Pressure		8[116]	7[100]	6[87]	5[73]	5[73]	5[73]	5[73]
with Unloaded Shaft, bar [PSI]								
Min. Starting Torque		28,2[2500]	33,5[2950]	42,8[3790]	40,50[45.8]	46,8[4140]	36[3180]	41,5[3670]
daNm [lb-in]	At max. press. drop Cont.	35,5[3140]	42,6[3770]	54,2[4795]	54,80[61.9]	60,8[5390]	54[4780]	62[5480]
Min. Speed***, RPM	At max. press. drop Int.*	10	10	10	10	10	10	10
Weight, kg [lb] For								
Rear Port + 0,450 [992]	GP	6[14.3]	6[14.8]	6,9[15.2]	7,2[15.9]	7,7[17]	9[19.9]	9[21.2]

Function Diagrams

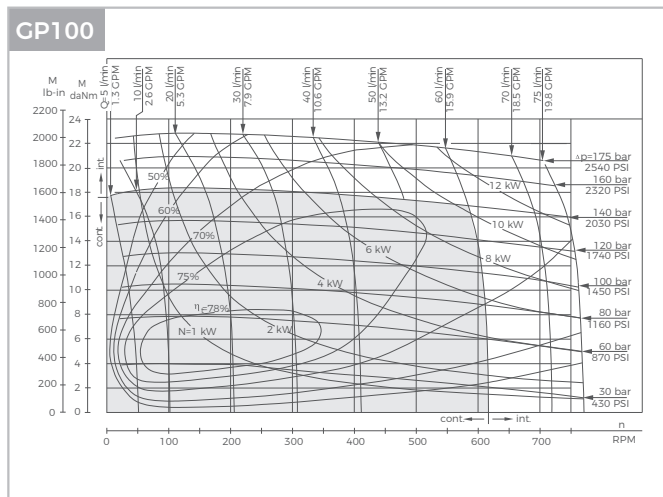
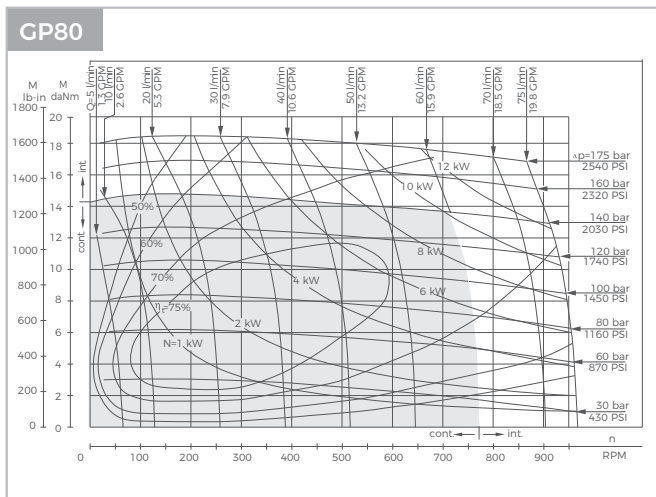
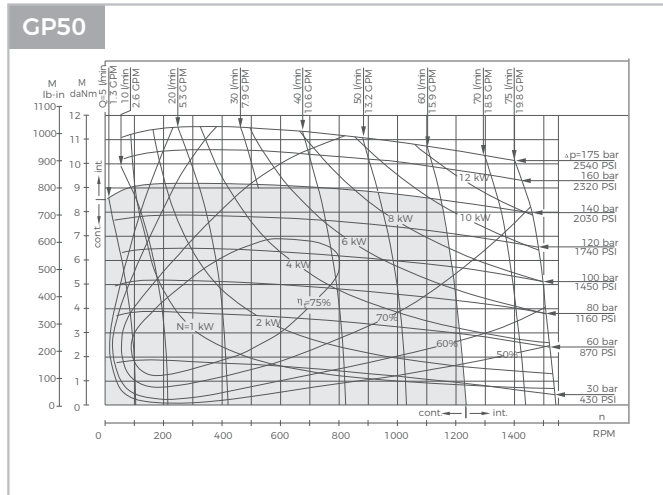
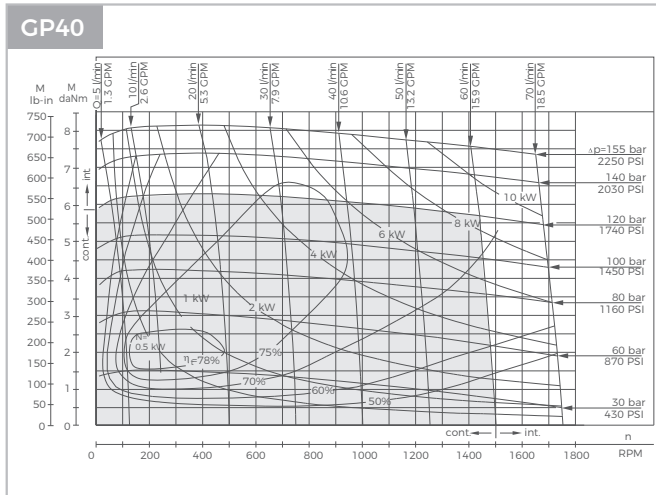
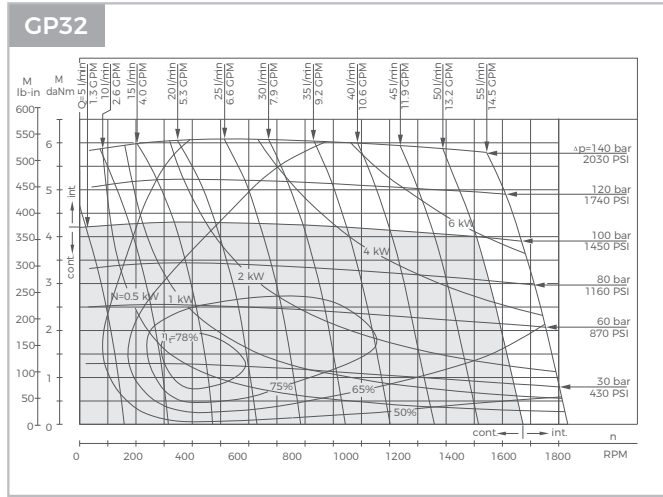
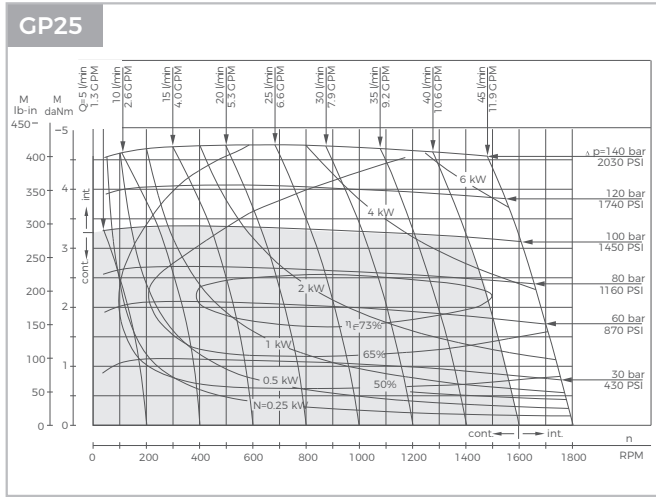

The function diagrams data is for average performance of randomly selected motors at backpressure. 5÷10 bar [72.5÷145 PSI] and oil with viscosity of 32 mm²/s [150 SUS] at 50°C [122°F].

Function Diagrams

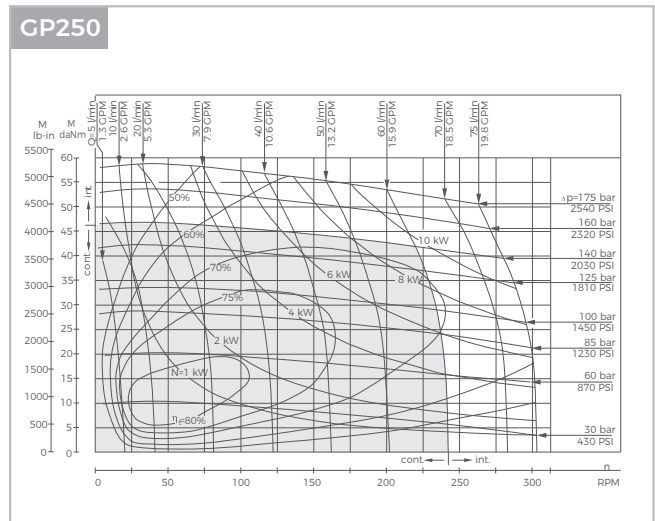
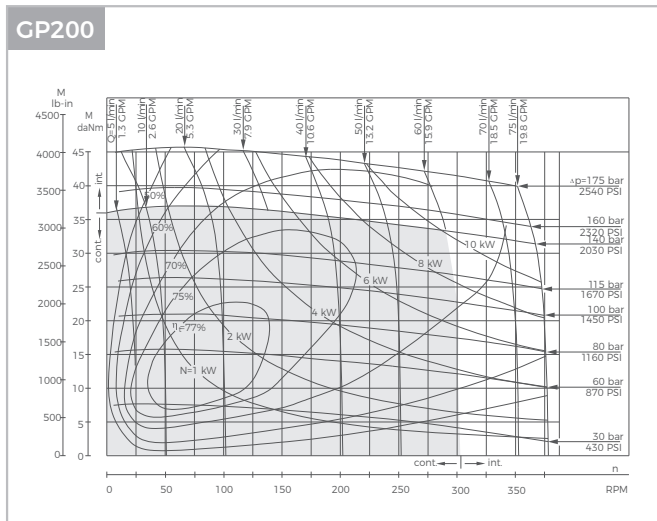
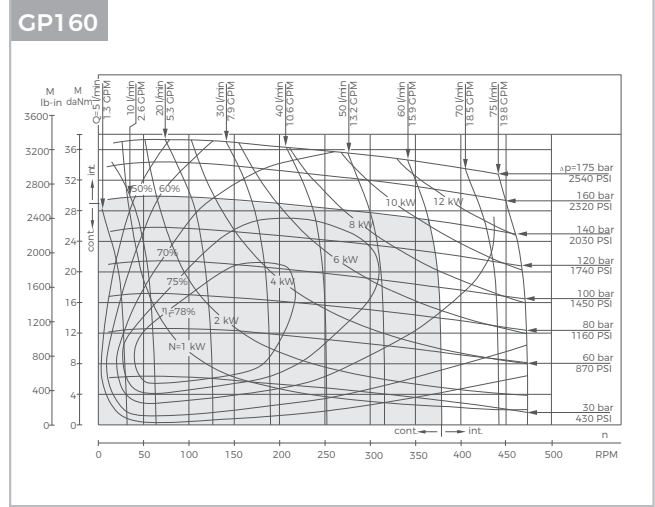
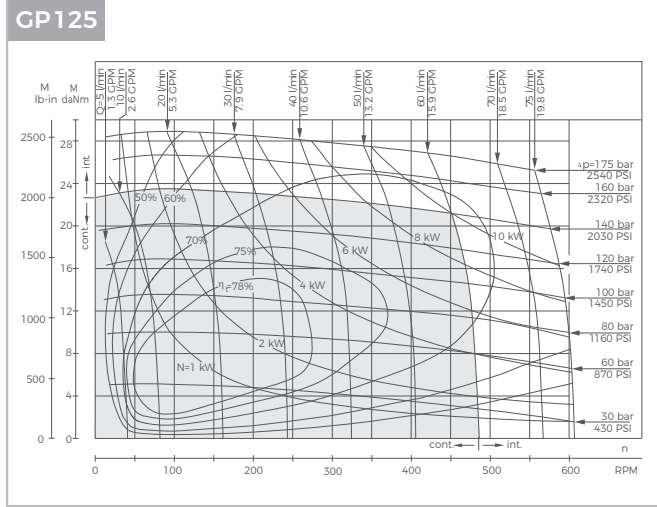

The function diagrams data is for average performance of randomly selected motors at backpressure. 5±10 bar [72.5±145 PSI] and oil with viscosity of 32 mm²/s [150 SUS] at 50°C [122°F].

Function Diagrams

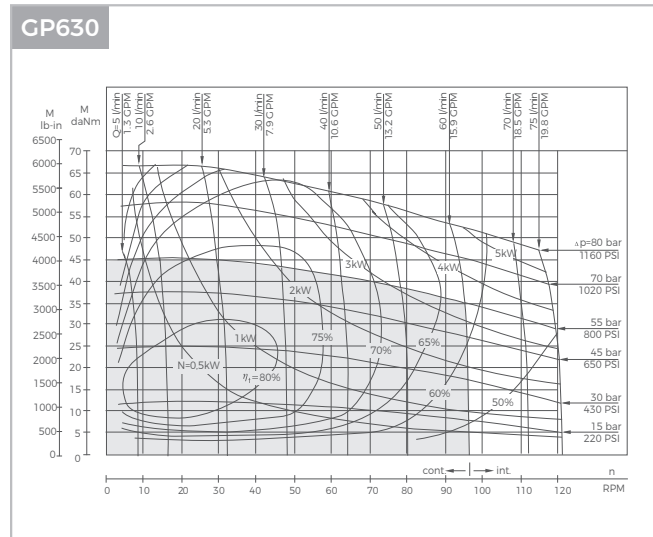
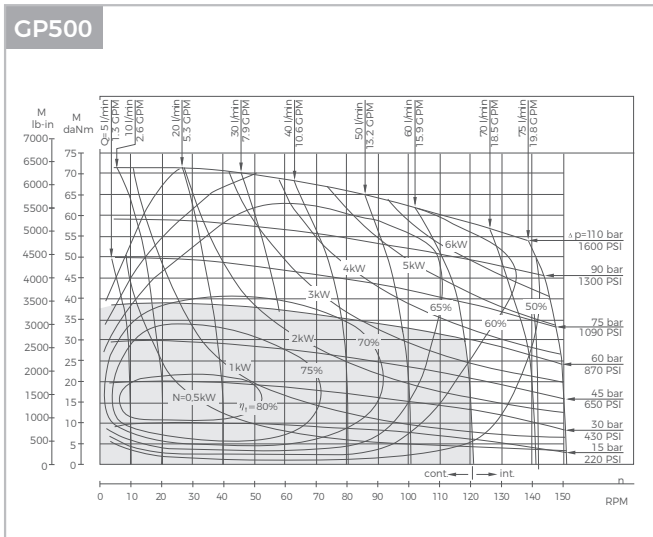
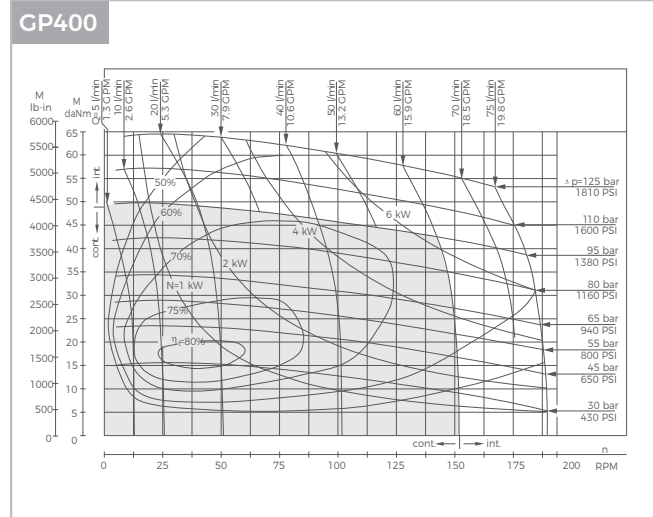
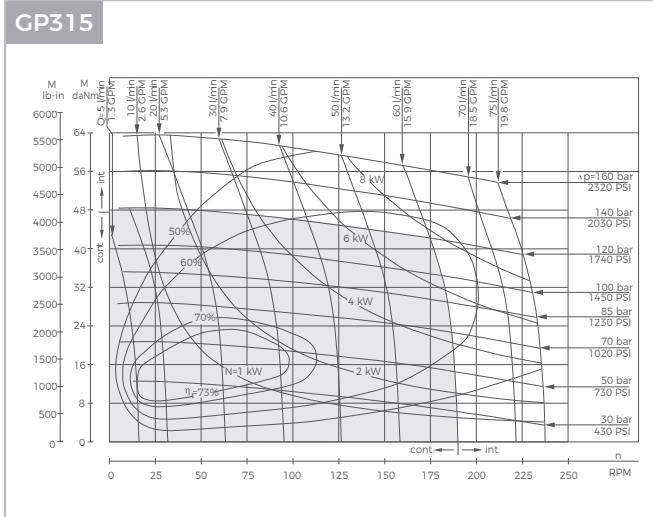

The function diagrams data is for average performance of randomly selected motors at backpressure. 5±10 bar [72.5÷145 PSI] and oil with viscosity of 32 mm²/s [150 SUS] at 50°C [122°F].

GP Dimensions and Mountings

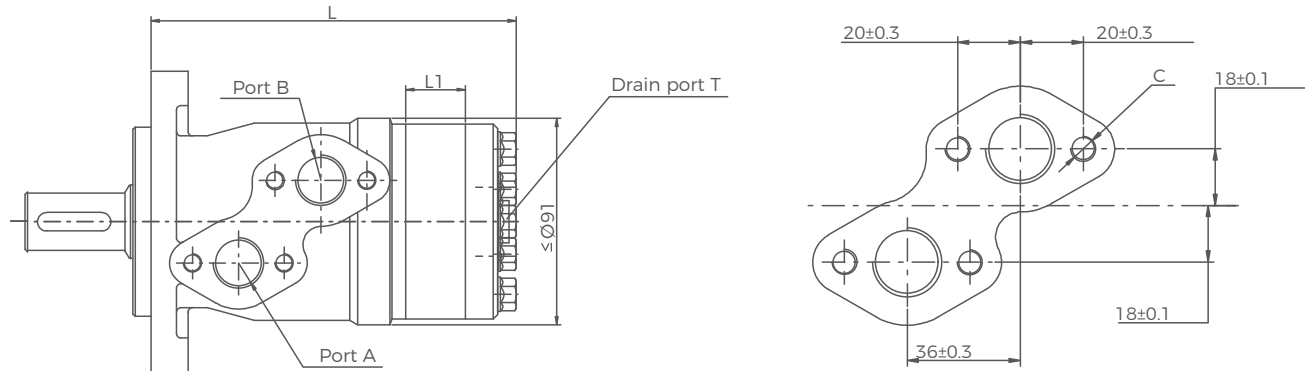

Model	L	L1
GP25	135	4.5
GP32	136	5.5
GP40	137	7
GP50	137	7
GP80	140.5	10.5
GP100	143	13
GP125	146	16
GP160	151	21
GP200	157	26
GP250	162	32
GP315	172	42
GP400	182	52
GP500	195	65
GP630	213	84

Mounting	G1 (depth)	M1 (depth)	U2 (depth)	U1 (depth)	G2 (depth)
P(A, B)	G1/2(15)	M22 x 1.5(15)	7/8-14 O-ring(17)	1/2-14NPTF(15)	PT(RC)1/2(15)
C	4-M8(13)	4-M8(13)	4-5/16-18UNC(13)	4-5/16-18UNC(13)	4-M8(13)
T	G1/4(12)	M14 x 1.5(12)	7/16-20UNF(12)	7/16-20UNF(12)	PT(RC)1/4(9.7)

GP Flange Covers Dimensions

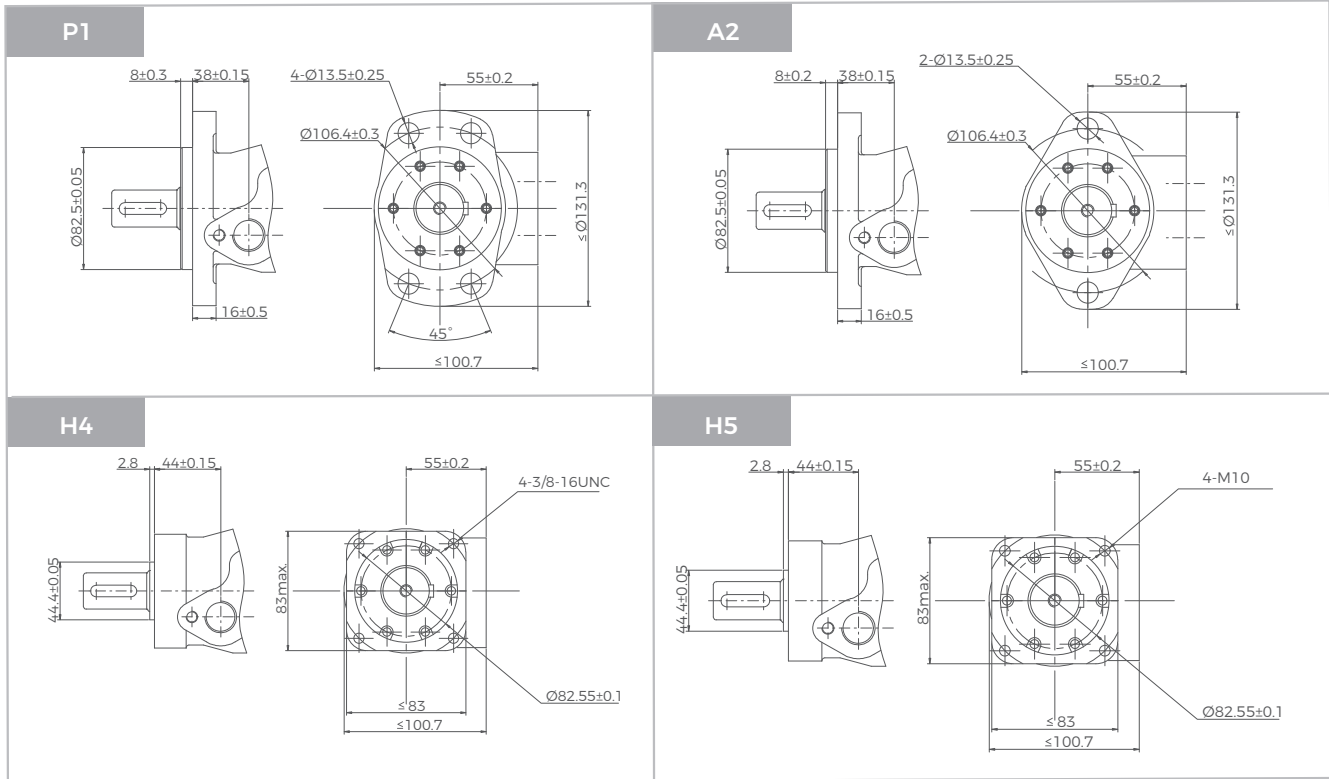

GP Shafts Dimensions

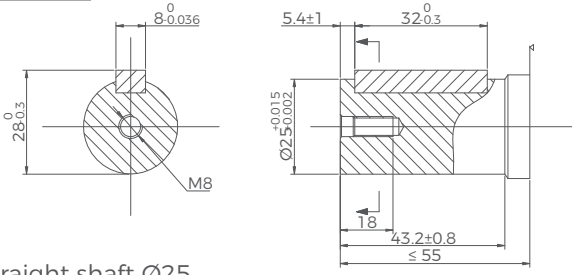
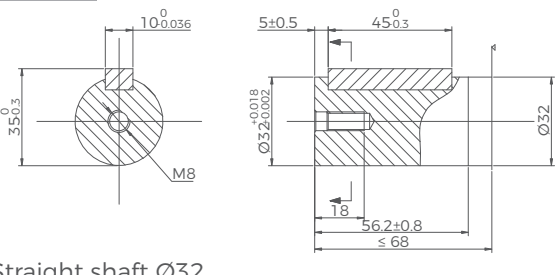
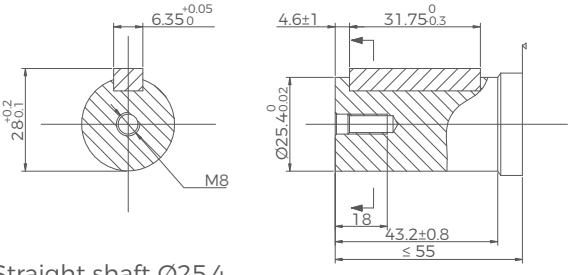
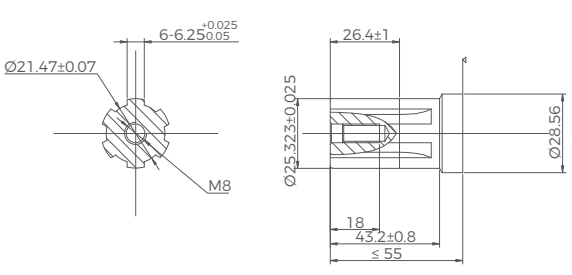
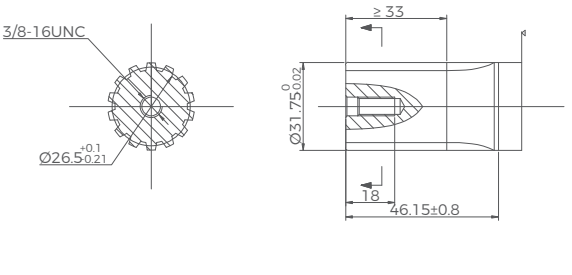
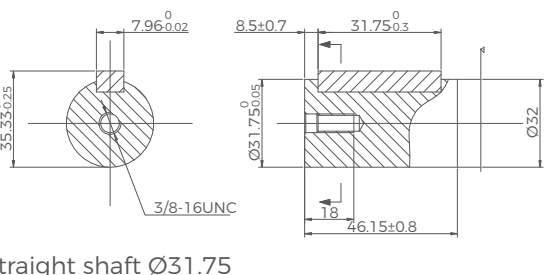
<p>S1</p>  <p>Straight shaft Ø25 Parallel key 8 x 7 x 32</p>	<p>S4</p>  <p>Straight shaft Ø32 Parallel key 10 x 8 x 45</p>
<p>S2</p>  <p>Straight shaft Ø25.4 Parallel key 6.35 x 6.35 x 31.75</p>	<p>R1</p>  <p>Splined shaft SAE 6B</p>
<p>R2</p>  <p>Splined shaft 14 - DP 12/24</p>	<p>S5</p>  <p>Straight shaft Ø31.75 Parallel key 7.96 x 7.96 x 31.75</p>

GP Shafts Dimensions

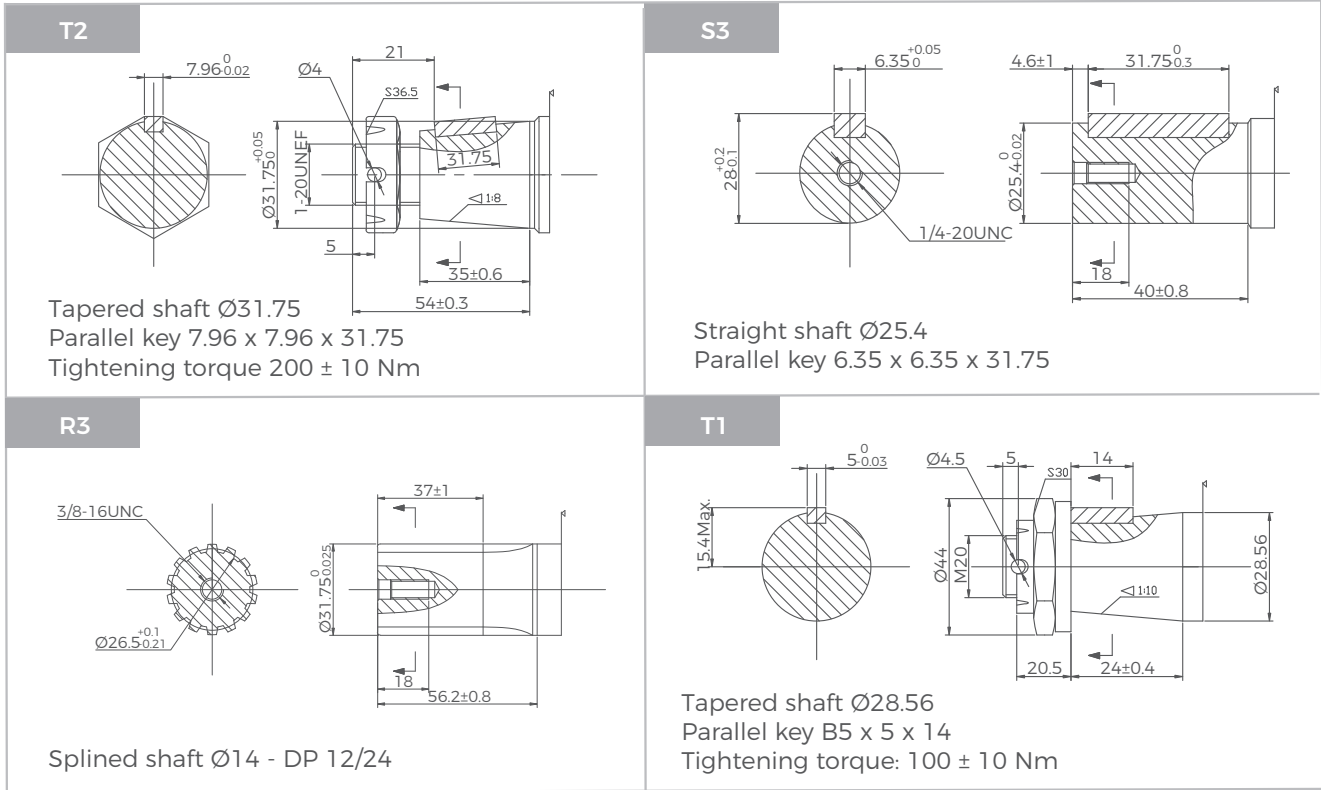

GP Series Hydraulic Motors

Permissible shaft seal pressure

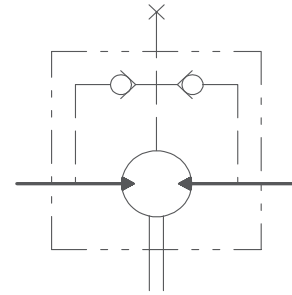
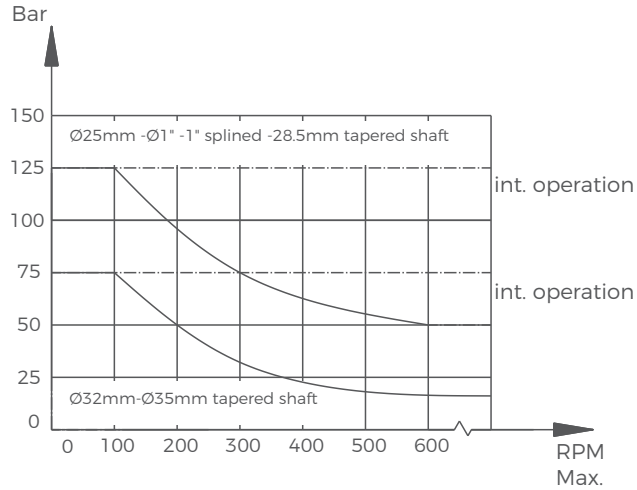

GP with standard shaft seal check valves and without use of drain connection: The pressure on the shaft seal never exceeds the pressure in the return line.

GP with standard shaft seal, check valves and with drain connection: The shaft seal pressure equals the pressure on the drain line.

Drain Port

In applications without drain line, output shaft seal exceeds a bit of the pressure in the return line. In applications using the drain line, the pressure of output shaft seal equals the pressure in drain line.

Standard direction of shaft rotation: Standard

When facing shaft end of motor, shaft to rotate:
Clockwise when port A is pressurized.
Counter-clockwise when port B is pressurized.

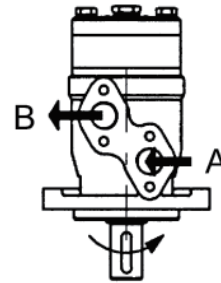

Output shaft stand radial force

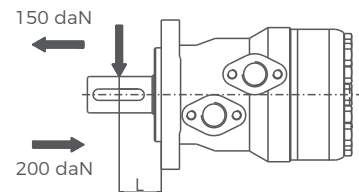
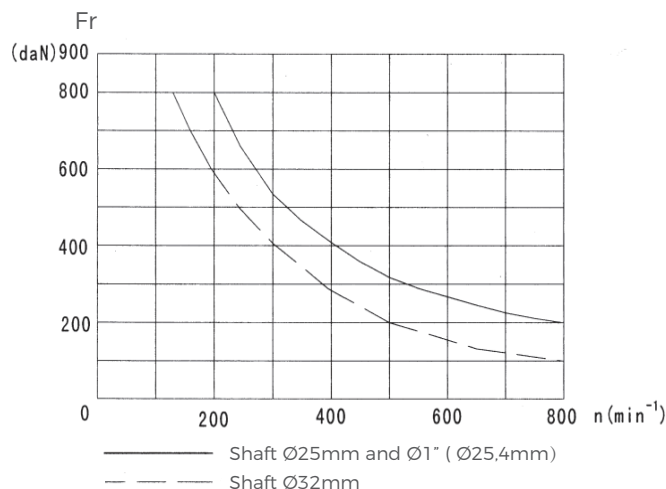

$$F_r = \frac{800}{n} * \frac{25000}{95 + L} \text{ (daN)}$$

F_r = Radial Force (daN)

L = Distance (mm)

n = Speed (rpm)

Rhomb flange $L = 30\text{mm}$

Square flange $L = 24\text{mm}$

GPH Series Hydraulic Motors

Options

- Flange connection
- Motor with needle roller bearing
- Speed sensing
- Side and bottom ports
- Shaft seal for high and low pressure
- Straight, splined and tapered shafts
- Metric and BSPP ports
- Other special features

Applications

- Conveyors
- Feeding mechanism of robots and manipulators
- Metal working machines
- Textile machines
- Agricultural machines
- Food industries
- Lawn mower



General

Max. Displacement	cm ³ /rev [in ³ /rev]	801,8 [48.91]
Max. Speed	RPM	630
Max. Torque	daNm [lb-in]	cont.:188 [16650] int.:211 [18650]
Max. Output	kW [HP]	64 [85,8]
Max. Pressure Drop	bar [PSI]	cont.: 200 [2900] int.: 240 [3480]
Max. Oil Flow	lpm [GPM]	240 [63.4]
Min. Speed	RPM	5
Pressure Fluid		Mineral based- HLP (DIN 51524) or HM (ISO 6743/4)
Temperature Range	°C [°F]	-40÷140 [-40÷284]
Optimal Viscosity Range	mm ² /s [SUS]	20÷75 [98÷347]
Filtration		ISO code 20/16 (Min. recommended fluid filtration of 25 microns)

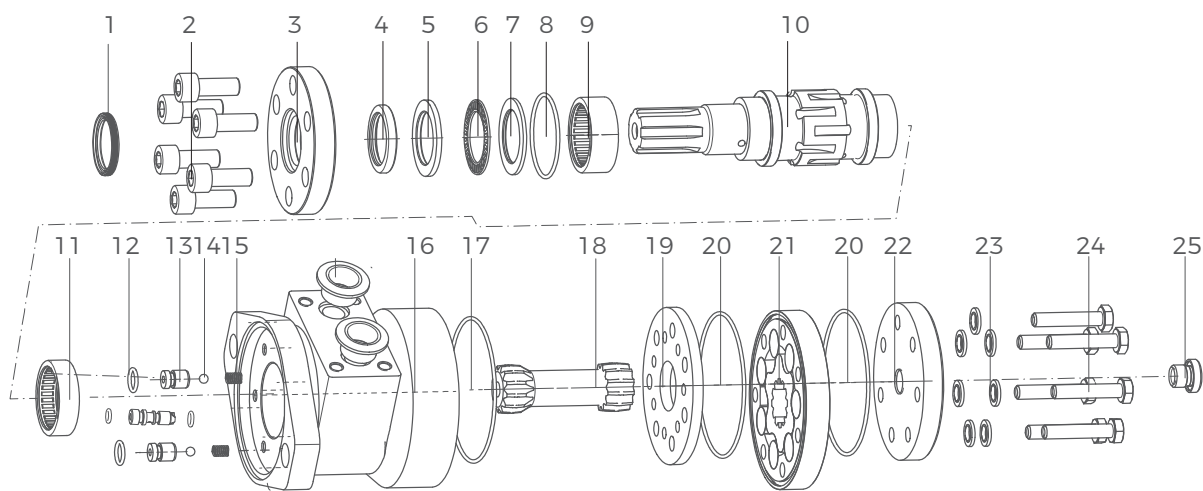

1 Anti-dust ring	6 Flat bearing	11 Needle roller bearing	16 Rubber plug	21 Stator assembly
2 Bolt	7 Bearing retainer	12 O-ring seal	17 Housing	22 Rear cover
3 Front cover	8 O-ring seal	13 Check valve	18 O-ring seal	23 Combination washer
4 Shaft seal	9 Needle roller bearing	14 Steel ball	19 Transmission shaft	24 Screw
5 Bearing retainer	10 Output shaft	15 Spring	20 Spacer	25 External drain plug

Specifications

Type		GPH25	GPH32	GPH40	GPH50	GPH80
Displacement, cm ³ /rev [in ³ /rev]		25[1.52]	32[1.95]	40[2.44]	49.5[3.02]	79.2[4.83]
Max. Speed,	Cont.	1600	1560	1500	1210	755
RPM	Int*	1815	1720	1750	1515	945
Max. Torque	Cont.	3,3[290]	4,3[380]	6,2[550]	9,4[835]	15,1[1340]
daNm [lb-in]	Int*	4,7[415]	6,1[540]	8,2[730]	11,9[1050]	19,5[1725]
	Peak**	6,7[595]	8,6[760]	10,7[950]	14,3[1285]	22,4[1985]
Max. Output	Cont.	4,5[6.0]	5,8[7.8]	8,4[11.5]	10,1[13.5]	10,2[13.7]
kW [HP]	Int*	6,1[8.2]	7,8[10.5]	11,6[15.5]	12,2[16.1]	12,5[16.8]
Max. Pressure Drop	Cont.	100[1450]	100[1450]	120[1750]	140[2030]	140[2030]
bar [PSI]	Int*	140[2030]	140[2030]	155[2250]	175[2540]	175[2540]
	Peak**	225[3260]	225[3260]	225[3260]	225[3260]	225[3260]
Max. Oil Flow	Cont.	40[10.5]	50[13.2]	60[15.9]	60[15.9]	60[15.9]
lpm [GPM]	Int*	45[11.9]	55[14.5]	70[18.5]	75[19.8]	75[19.8]
Max. Inlet Pressure	Cont.	175[2540]	175[2540]	175[2540]	175[2540]	175[2540]
bar [PSI]	Int*	200[2900]	200[2900]	200[2900]	200[2900]	200[2900]
	Peak**	225[3260]	225[3260]	225[3260]	225[3260]	225[3260]
Max. Return Pressure	Cont.	175[2540]	175[2540]	175[2540]	175[2540]	175[2540]
without Drain Line	Int*	200[2900]	200[2900]	200[2900]	200[2900]	200[2900]
bar [PSI]	Peak**	225[3260]	225[3260]	225[3260]	225[3260]	225[3260]
Max. Starting Pressure		10[145]	10[145]	10[145]	10[145]	10[145]
with Unloaded Shaft, bar [PSI]						
Min. Starting Torque	At max. press. drop Cont.	3,0[265]	4,0[355]	5,4[480]	7,8[690]	13,2[1170]
daNm [lb-in]	At max. press. drop Int*	4,2[370]	5,6[500]	6,8[600]	10[885]	16,8[1490]
Min. Speed***, RPM		20	15	10	10	10
Weight, kg [lb] For	GPH	5,6[12.3]	5,6[12.3]	5,7[12.6]	5,8[12.8]	5,9[13.2]
rear port + 0.450 [992]						

Specifications

Type		GPH100	GPH125	GPH160	GPH200
Displacement, cm ³ /rev [in ³ /rev]		99[6.04]	123,8[7.55]	158,4[9.66]	198[12.1]
Max. Speed,	Cont.	605	486	378	303
RPM	Int*	755	605	472	378
Max. Torque	Cont.	19,3[1710]	23,7[2100]	31,3[2770]	36,6[3240]
daNm [lb-in]	Int*	23,7[2100]	29,8[2640]	37,8[3345]	45,6[4035]
	Peak**	27,5[2435]	36,5[3235]	43,8[3880]	55[4870]
Max. Output	Cont.	10,5[14.1]	10,2[13.7]	10,1[13.5]	10[13.5]
kW [HP]	Int*	12,8[17.1]	12[16.1]	12,1[16.2]	12[16.1]
Max. Pressure Drop	Cont.	140[2030]	140[2030]	140[2030]	140[2030]
bar [PSI]	Int*	175[2540]	175[2540]	175[2540]	175[2540]
	Peak**	225[3260]	225[3260]	225[3260]	225[3260]
Max. Oil Flow	Cont.	60[15.9]	60[15.9]	60[15.9]	60[15.9]
lpm [GPM]	Int*	75[19.8]	75[19.8]	75[19.8]	75[19.8]
Max. Inlet Pressure	Cont.	175[2540]	175[2540]	175[2540]	175[2540]
bar [PSI]	Int*	200[2900]	200[2900]	200[2900]	200[2900]
	Peak**	225[3260]	225[3260]	225[3260]	225[3260]
Max. Return Pressure	Cont.	175[2540]	175[2540]	175[2540]	175[2540]
without Drain Line	Int*	200[2900]	200[2900]	200[2900]	200[2900]
bar [PSI]	Peak**	225[3260]	225[3260]	225[3260]	225[3260]
Max. Starting Pressure		10[145]	9[131]	8[116]	7[100]
with Unloaded Shaft, bar [PSI]					
Min. Starting Torque	At max. press. drop Cont.	16,6[1470]	20,7[1830]	28,2[2500]	33,5[2950]
daNm [lb-in]	At max. press. drop Int*	21[1860]	26,6[2360]	35,5[3140]	42,6[3770]
Min. Speed***, RPM		10	10	10	10
Weight, kg [lb] For	GPH	6,1[13.5]	6,2[13.7]	6,4[14.1]	6,6[14.6]
rear port + 0,450 [992]					

Specifications

Type		GPH250	GPH315	GPH400	GPH500	GPH630
Displacement, cm ³ /rev [in ³ /rev]		247,5[15.1]	316,8[19.3]	396[24.16]	495[30.2]	623,6[38.05]
Max. Speed,	Cont.	242	190	150	120	95
RPM	Int*	303	236	189	150	120
Max. Torque	Cont.	38[3360]	38[3360]	36[3190]	39[3452]	44[3895]
daNm [lb-in]	Int*	58,3[5160]	56[4960]	59[5240]	57[5045]	64[5665]
	Peak**	68,5[6060]	85[7505]	85,4[7560]	78[6903]	82[7257]
Max. Output	Cont.	7,5[10]	5,8[7.9]	4,6[6.2]	3,5[4.7]	3,3[4.4]
kW [HP]	Int*	12[16.1]	9[12.1]	7,8[10.5]	7,2[9.7]	5,6[7.5]
Max. Pressure Drop	Cont.	110[1600]	90[1300]	70[1015]	60[870]	55[800]
bar [PSI]	Int*	175[2540]	140[2030]	115[1665]	90[1305]	80[1160]
	Peak**	225[3260]	225[3260]	180[2610]	130[1885]	110[1740]
Max. Oil Flow	Cont.	60[15.9]	60[15.9]	60[15.9]	60[15.9]	60[15.9]
lpm [GPM]	Int*	75[19.8]	75[19.8]	75[19.8]	75[19.8]	75[19.8]
Max. Inlet Pressure	Cont.	175[2540]	175[2540]	175[2540]	140[2030]	140[2030]
bar [PSI]	Int*	200[2900]	200[2900]	200[2900]	175[2540]	175[2540]
	Peak**	225[3260]	225[3260]	225[3260]	225[3260]	225[3260]
Max. Return Pressure	Cont.	175[2540]	175[2540]	175[2540]	140[2030]	140[2030]
without Drain Line	Int*	200[2900]	200[2900]	200[2900]	175[2540]	175[2540]
bar [PSI]	Peak**	225[3260]	225[3260]	225[3260]	225[3260]	225[3260]
Max. Starting Pressure						
with Unloaded Shaft, bar [PSI]		6[87]	5[73]	5[73]	5[73]	5[73]
Min. Starting Torque	At max. press. drop Cont.	33,6[2970]	34,4[3045]	34,5[3050]	36[3180]	41,5[3670]
daNm [lb-in]	At max. press. drop Int*	54,2[4795]	61,9[5480]	60,8[5390]	54[4780]	62[5480]
Min. Speed***, RPM		10	10	10	10	10
Weight, kg [lb] For rear port + 0,450 [992]	GPH	6,8[15]	7,1[15.6]	7,6[16.8]	8,9[20]	9,5[21.4]

Function Diagrams

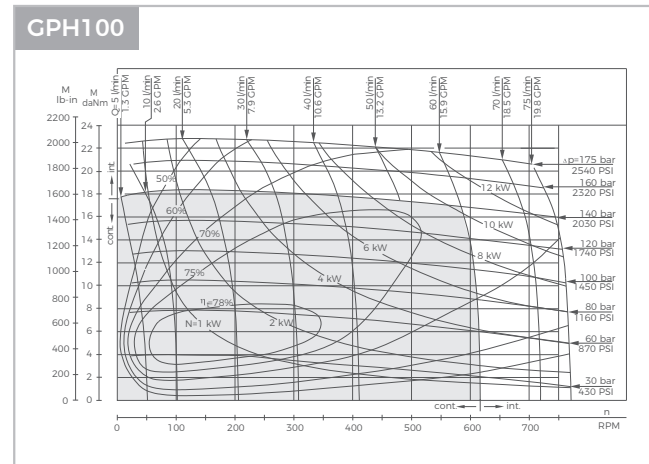
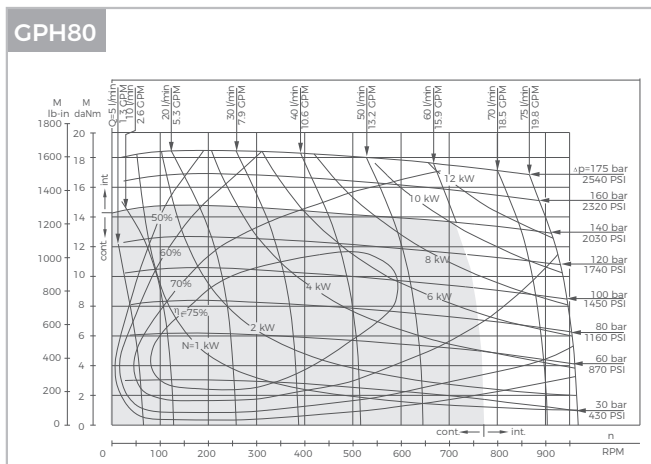
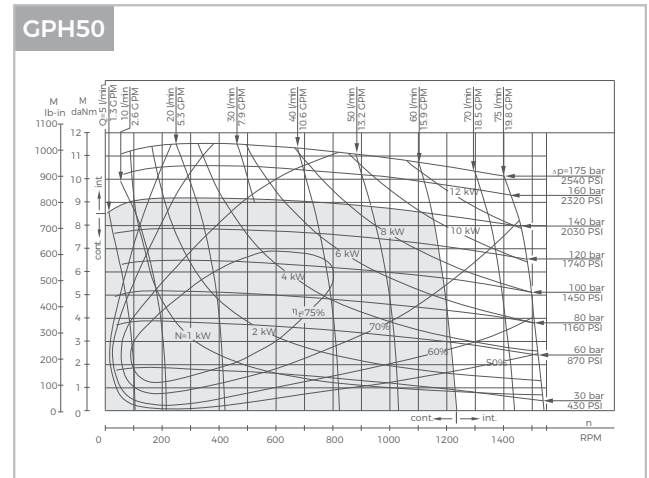
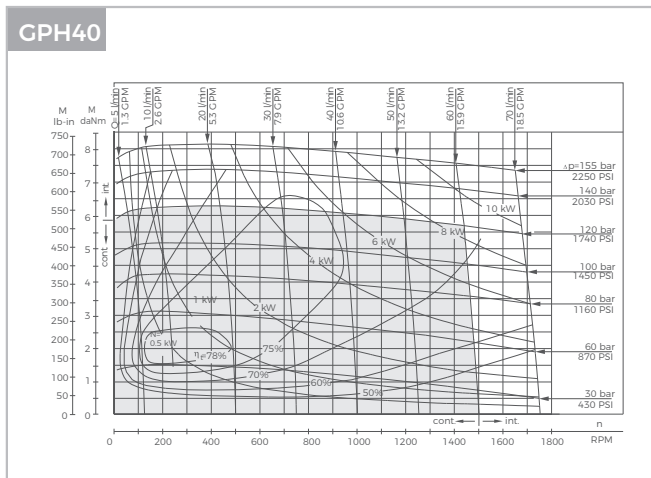
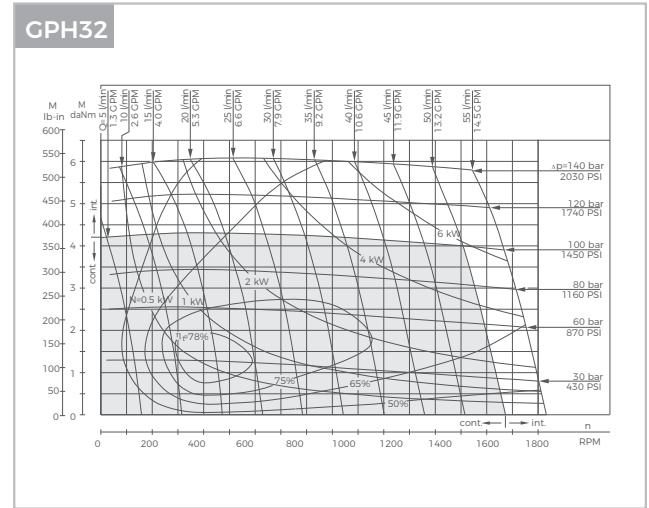
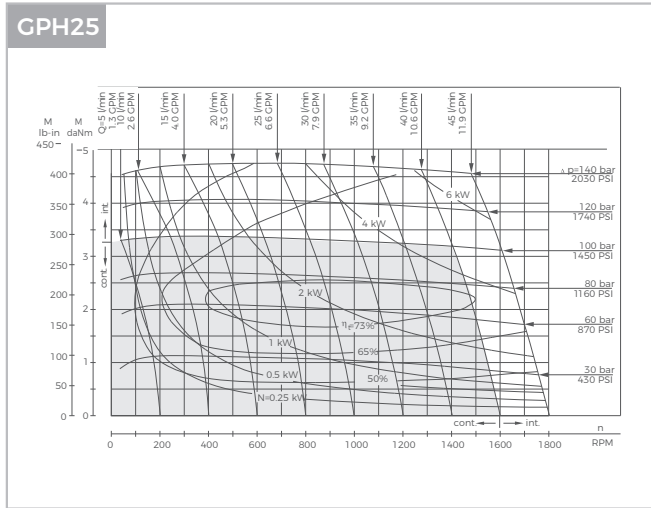

The function diagrams data is for average performance of randomly selected motors at backpressure. 5÷10 bar [72.5÷145 PSI] and oil with viscosity of 32 mm²/s [150 SUS] at 50°C [122°F].

Function Diagrams

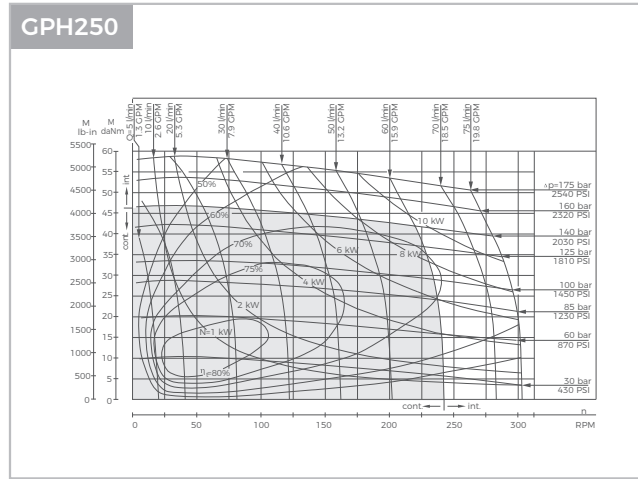
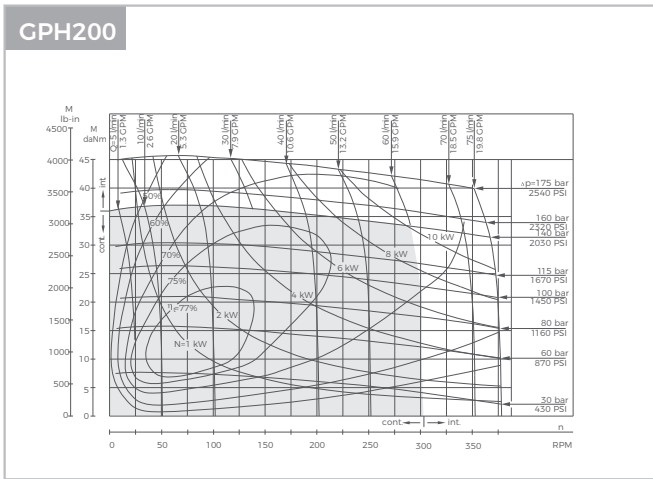
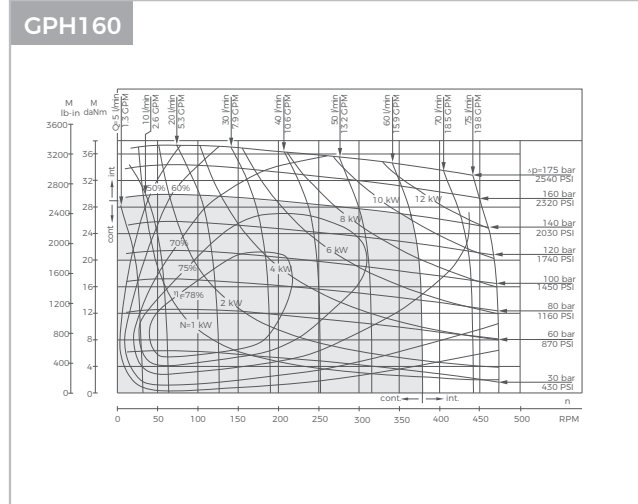
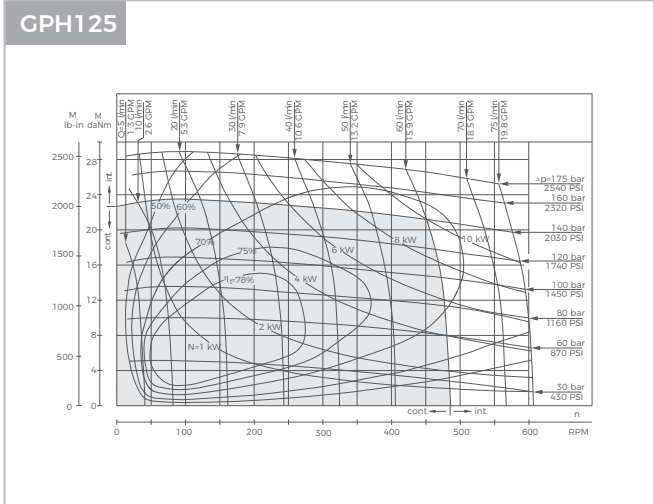

The function diagrams data is for average performance of randomly selected motors at backpressure. 5±10 bar [72.5±145 PSI] and oil with viscosity of 32 mm²/s [150 SUS] at 50°C [122°F].

Function Diagrams

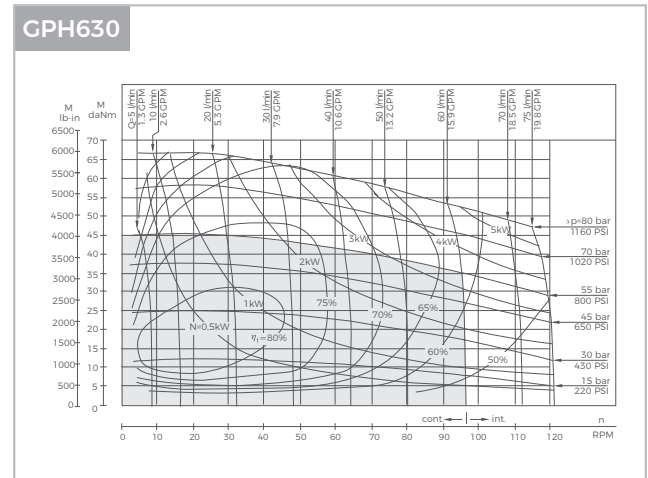
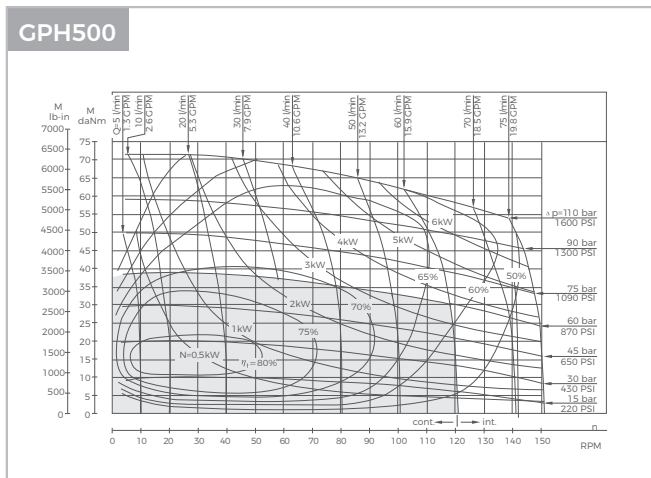
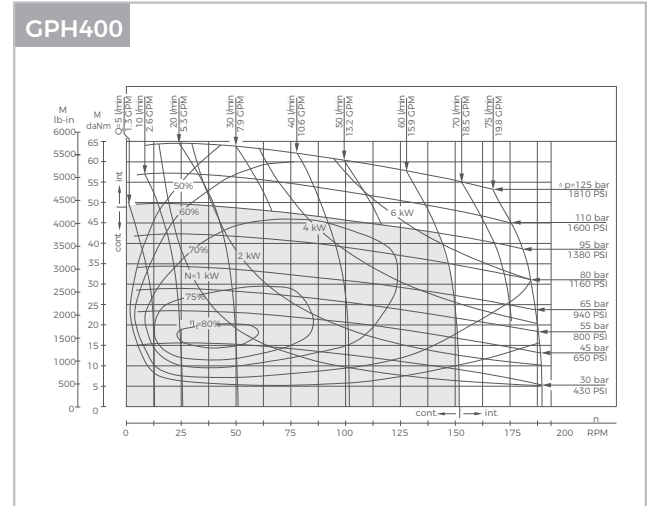
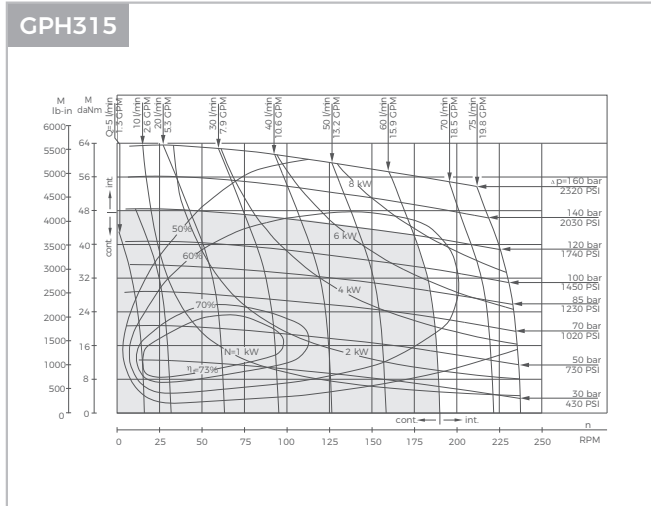

The function diagrams data is for average performance of randomly selected motors at backpressure. 5±10 bar [72.5÷145 PSI] and oil with viscosity of 32 mm²/s [150 SUS] at 50°C [122°F].

GPH Dimensions and Mountings

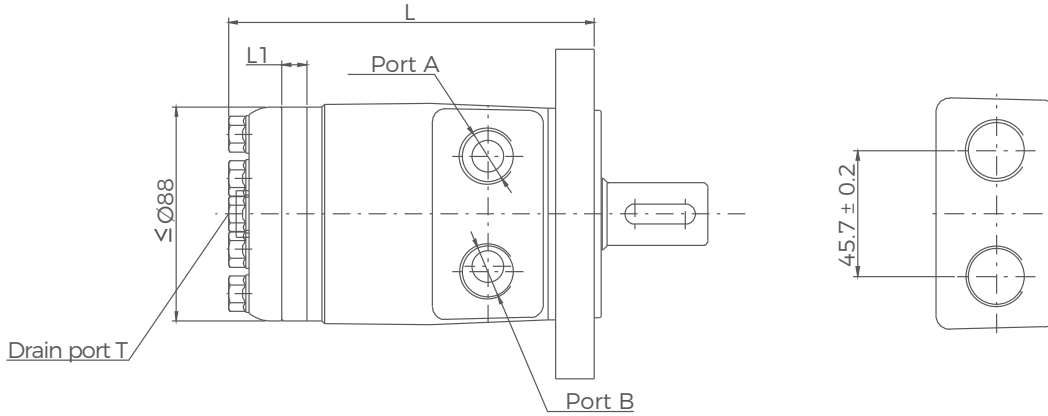

Model	L	L1
GPH40	136	5.5
GPH50	137	7
GPH80	144.5	10.5
GPH100	147	13
GPH125	150	16
GPH160	155	21
GPH200	160	26
GPH250	166	32
GPH315	176	42
GPH400	186	52
GPH500	199	65
GPH630	203	84

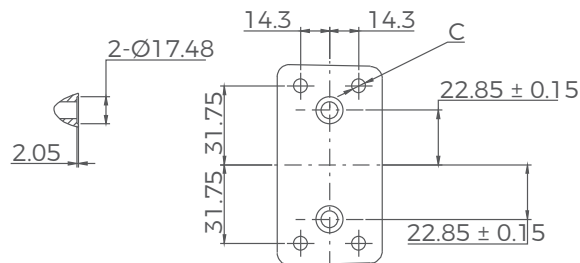

Mounting	G7 (depth)	U9 (depth)	UA (depth)	U3 (depth)	G8 (depth)	D1 (depth)	D2 (depth)
P(A, B)	G1/2(15)	7/8-14 O-ring(17)	1/2-14NPTF(15)	3/4-16 O-ring(15)	PT(RC)1/2(15)	$\varnothing 10$	$\varnothing 10$
T	G1/4(12)	7/16-20UNF(12)	7/16-20UNF(12)	7/16-20UNF(12)	PT(RC)1/4(9.7)	7/16-20UNF(12)	G1/4(12)
C	—	—	—	—	—	4-5/16-18UNC(13)	4-M8(13)

GPH Flange Covers Dimensions

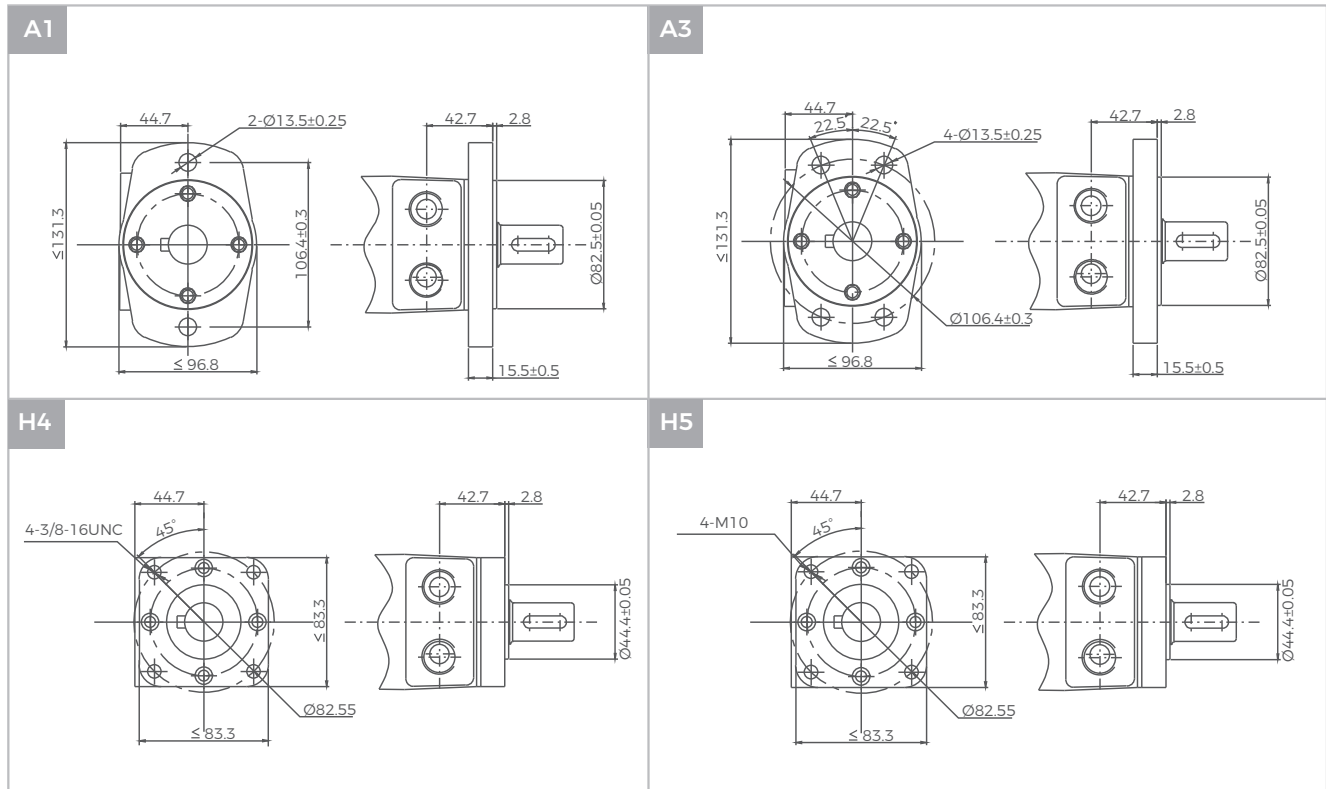

GPH Shafts Dimensions

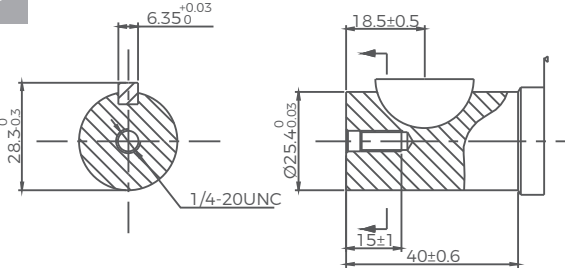
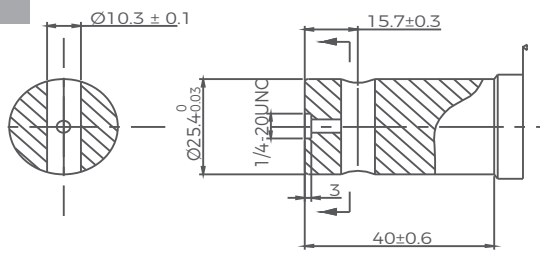
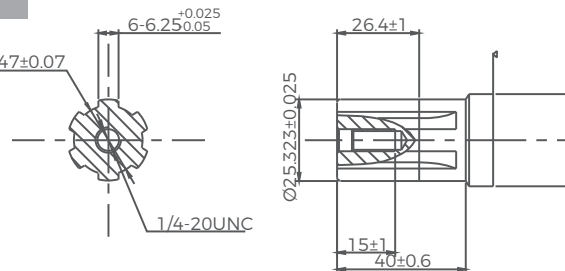
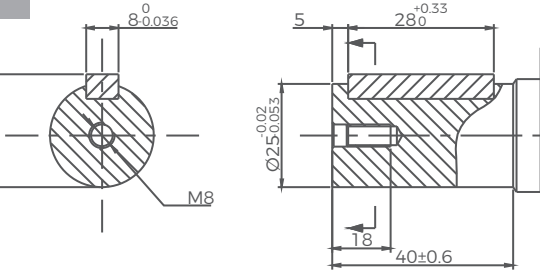
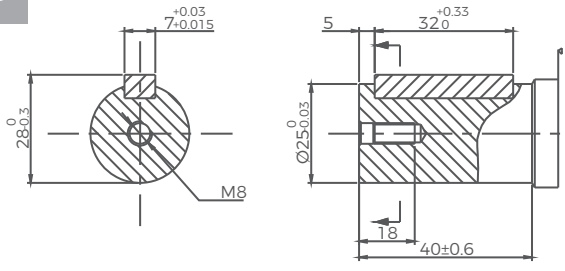
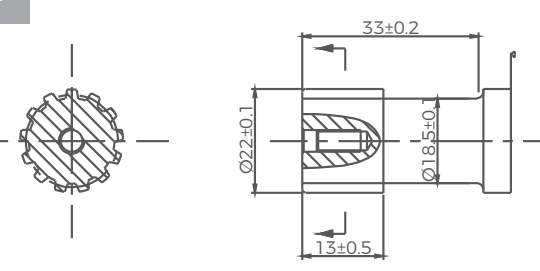
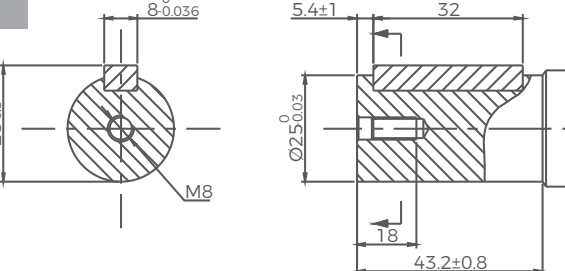
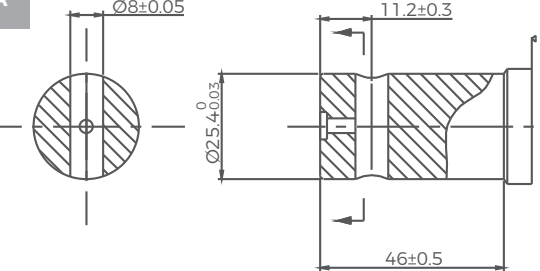
<p>S6</p>  <p>Straight shaft $\text{Ø}25.4$ Woodruff key 25.4 x 6.35</p>	<p>S9</p>  <p>Straight shaft $\text{Ø}25.4$ Pin hole $\text{Ø}10.3$</p>
<p>R4</p>  <p>Splined shaft SAE 6B</p>	<p>SC</p>  <p>Straight shaft $\text{Ø}25$ Parallel key 8 x 7 x 28</p>
<p>SD</p>  <p>Straight shaft $\text{Ø}25$ Parallel key 7 x 7 x 32</p>	<p>R5</p>  <p>Splined shaft 13-DP 16/32</p>
<p>S7</p>  <p>Straight shaft $\text{Ø}25$ Parallel key 8 x 7 x 32</p>	<p>SA</p>  <p>Straight shaft $\text{Ø}25.4$ Pin hole $\text{Ø}8$</p>

GPH Shafts Dimensions

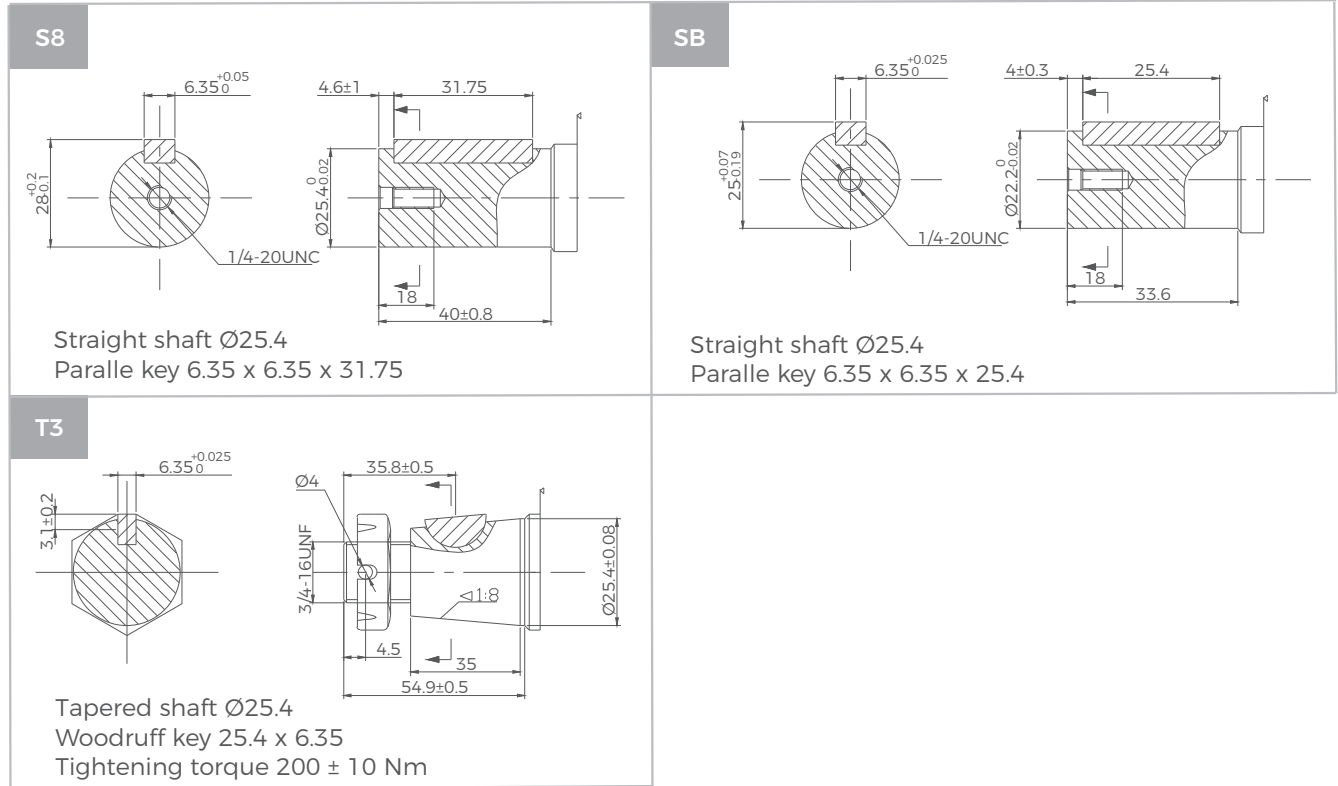

GPH Series Hydraulic Motors

Permissible shaft seal pressure

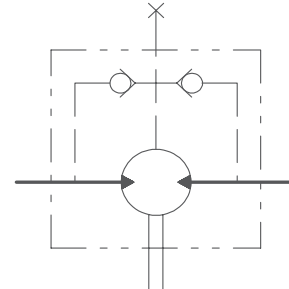
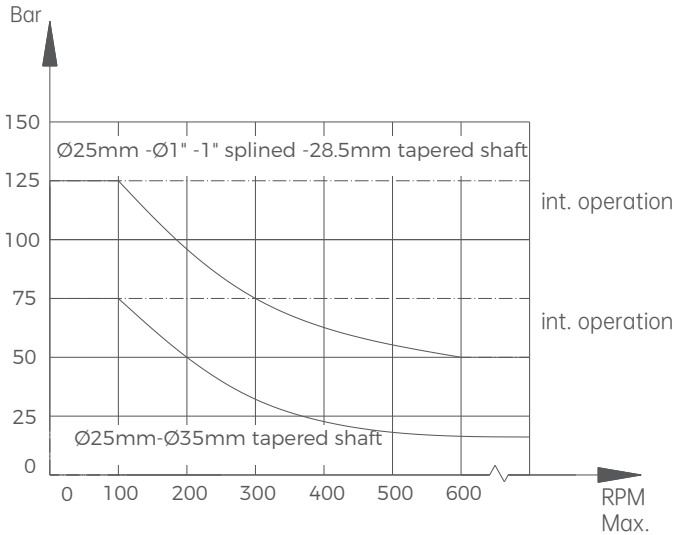

GPH with standard shaft seal check valves and without use of drain connection: The pressure on the shaft seal never exceeds the pressure in the return line.

GPH with standard shaft seal, check valves and with drain connection: The shaft seal pressure equals the pressure on the drain line.

Drain Port

In applications without drain line, output shaft seal exceeds a bit of the pressure in the return line. In applications using the drain line, the pressure of output shaft seal equals the pressure in drain line.

Standard direction of shaft rotation: Standard

When facing shaft end of motor, shaft to rotate:
 Clockwise. When port A is pressurized.
 Counter-clockwise. When port B is pressurized.

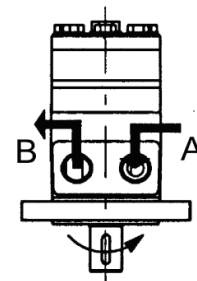

Output shaft stand radial force

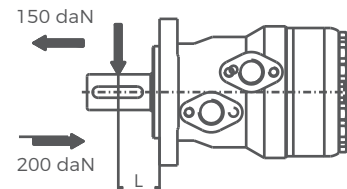
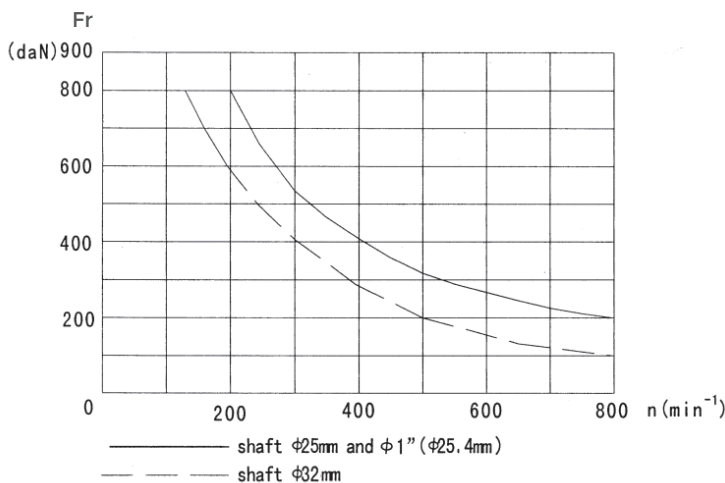

$$Fr = \frac{800}{n} * \frac{25000}{95 + L} \text{ (daN)}$$

Fr = Radial Force (daN)

L = Distance (mm)

n = Speed (rpm)

Rhomb-flange L = 30mm

Square-flange L = 24mm

GR Series Hydraulic Motors

Options

- Flange connection
- Motor with needle bearing
- Side and rear ports
- Straight, splined and tapered shafts
- Shaft seal for high and low pressure
- Metric and BSPP ports
- Speed sensing
- Other special features

Applications

- Conveyors
- Feeding mechanism of robots and manipulators
- Metal working machines
- Textile machines
- Agricultural machines
- Food industries
- Lawn mower







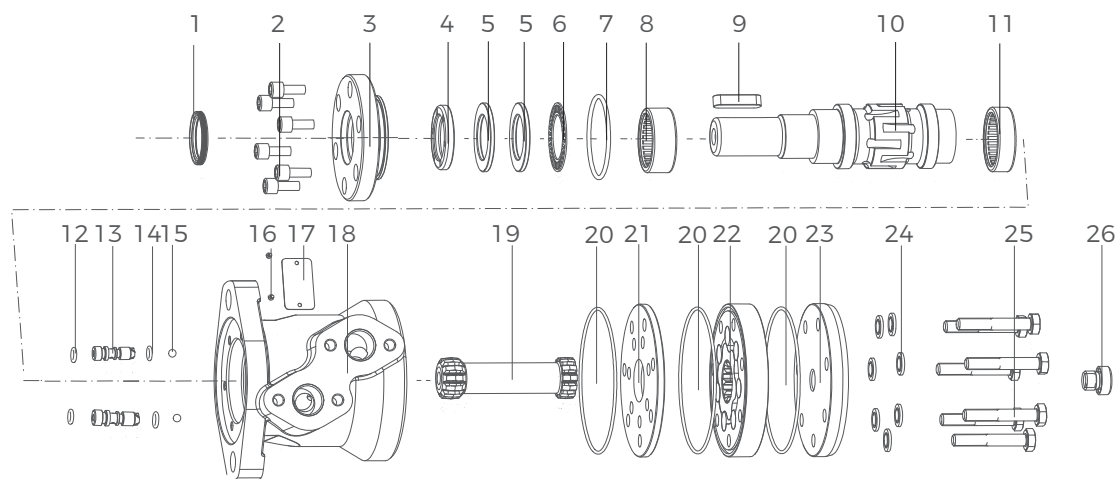

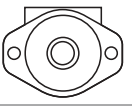
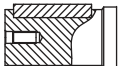
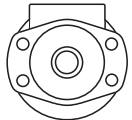

General

Max. Displacement	cm ³ /rev [in ³ /rev]	397 [24.4]
Max. Speed	RPM	970
Max. Torque	daNm [lb-in]	cont.:61 [5400] int.:69 [6100]
Max. Output	kW [HP]	15 [20.1]
Max. Pressure Drop	bar [PSI]	cont.:175 [2540] int.:200 [2900]
Max. Oil Flow	lpm [GPM]	75 [20]
Min. Speed	RPM	10
Pressure fluid		Mineral based- HLP (DIN 51524) or HM (ISO 6743/4)
Temperature Range	°C [°F]	-40÷140 [-40÷284]
Optimal Viscosity range	mm ² /s [SUS]	20÷75 [98÷347]
Filtration		ISO code: 20/16 (Min. recommended fluid filtration of 25 microns)

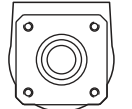

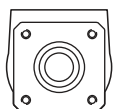
- | | | | | |
|---------------------------|-------------------------|--------------------------|-----------------------|------------------------|
| 1 Anti-dust ring | 6 Needle roller bearing | 11 Needle roller bearing | 16 Nameplate rivet | 21 Spacer |
| 2 Bolt | 7 O-ring seal | 12 O-ring seal | 17 Nameplate | 22 Rotor and stator |
| 3 Front cover | 8 Needle roller bearing | 13 Check valve | 18 Housing | 23 Rear cover |
| 4 Pressure resistant seal | 9 Parallel Key | 14 O-ring seal | 19 Transmission shaft | 24 Washer |
| 5 Retainer | 10 Output shaft | 15 Steel ball | 20 O-ring seal | 25 Bolt |
| | | | | 26 External drain plug |

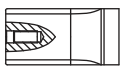
Ordering Code

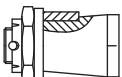
GR SERIES		DISP	FLANGE		SHAFT	PORTS		ROTATION	PAINT	FUNCTION	
CODE	DISP	CODE	FLANGE	CODE	SHAFT	CODE	PORTS	CODE	PAINT	CODE	FUNCTION
50	51.5cm ³ /rev [3.14in ³ /rev]	A2	2-Ø13.5 SAE A pilot Ø82.5×2.8 	S1	Ø25, parallel key 8×7×32 	G1	G1/2, G1/4 manifold 4×M8	A	No Paint	A	Standard
80	80.3cm ³ /rev [4.90in ³ /rev]	A4	4-Ø13.5 SAE A pilot Ø82.5×2.8 	S2	Ø25.4, parallel key 6.35×6.35×31.75 	M1	M22×1.5, M14×1.5 manifold 4×M8	B	Blue	N	Big radial force
100	99.8cm ³ /rev [6.09in ³ /rev]	H4	4-3/8-16 square, pilot Ø44.4×2.8 	R1	Ø25.4, splined tooth SAE 6B 	U2	7/8-14UNF O-ring, 7/16-20UNF manifold 4×5/16-18UNC	C	Black	D	No case drain
125	125.7cm ³ /rev [7.67in ³ /rev]	H5	4-M10 square, pilot Ø44.4×2.8 	S3	Short: Ø25.4, parallel key 6.35×6.35×31.75 	U1	1/2-14NPTF, 7/16-20UNF manifold 4×5/16-18UNC	S	Silver grey	F	Free running
160	159.6cm ³ /rev [9.74in ³ /rev]			S4	Ø32, parallel key 10×8×45 	G2	PT(Rc)1/2, PT(Rc)1/4 manifold 4×M8			L	Low speed
200	199.8cm ³ /rev [12.19in ³ /rev]			R2	Ø31.75, splined tooth 14-DP 12/24 					V	High temp.
250	250.1cm ³ /rev [15.26in ³ /rev]			S5	Ø31.75, parallel key 7.96×7.96×31.75 					S	Low temp.
315	315.7cm ³ /rev [19.26in ³ /rev]			T1	Tapered Ø28.56, parallel key B5×5×14 						
400	397cm ³ /rev [24.4in ³ /rev]										

Specifications

Type		GR50	GR80	GR100	GR125	GR160
Displacement, cm ³ /rev [in ³ /rev]		51,5[3.14]	80,3[4.90]	99,8[6.09]	125,7[7.67]	159,6[9.74]
Max. Speed,	Cont.	775	750	600	457	375
RPM	Int.*	970	940	750	600	470
Max. Torque	Cont.	10[900]	20[1770]	24[2125]	30[2655]	39[3450]
daNm [lb-in]	Int.*	13[1150]	22[1947]	28[2480]	34[3010]	43[3805]
	Peak**	17[1505]	27[2390]	32[2832]	37[3275]	46[4070]
Max. Output	Cont.	7[9.5]	12,5[17]	13[17.4]	12,5[16.8]	11,5[15.4]
kW [HP]	Int.*	8,5[11.9]	15[20.1]	15[20.1]	14,5[19.5]	14[18.8]
Max. Pressure Drop	Cont.	140[2030]	175[2540]	175[2540]	175[2540]	175[2540]
bar [PSI]	Int.*	175[2540]	200[2900]	200[2900]	200[2900]	200[2900]
	Peak**	225[3260]	225[3260]	225[3260]	225[3260]	225[3260]
Max. Oil Flow	Cont.	40[10.5]	60[15.8]	60[15.8]	60[15.8]	60[15.8]
lpm [GPM]	Int.*	50[13.2]	75[19.8]	75[19.8]	75[19.8]	75[19.8]
Max. Inlet Pressure	Cont.	175[2540]	175[2540]	175[2540]	175[2540]	175[2540]
bar [PSI]	Int.*	200[2900]	200[2900]	200[2900]	200[2900]	200[2900]
	Peak**	225[3260]	225[3260]	225[3260]	225[3260]	225[3260]
Max. Return Pressure	Cont.	175[2540]	175[2540]	175[2540]	175[2540]	175[2540]
without Drain Line	Int.*	200[2900]	200[2900]	200[2900]	200[2900]	200[2900]
bar [PSI]	Peak**	225[3260]	225[3260]	225[3260]	225[3260]	225[3260]
Max. Starting Pressure		10[145]	10[145]	10[145]	9[130]	7[102]
with Unloaded Shaft, bar [PSI]						
Min. Starting Torque	At max. press. drop Cont.	8[710]	15[1330]	20[1770]	25[2215]	32[2832]
daNm [lb-in]	At max. press. drop Int.*	10[85]	17[1505]	23[2035]	28[2480]	37[3275]
Min. Speed***, RPM		10	10	10	10	10
Weight, kg [lb] For						
rear port + 0,650 [1.433]	GR	6,8[15]	6,9[15.2]	7,2[15.9]	7,3[16.1]	7,5[15.2]

Specifications

Type		GR200	GR250	GR315	GR400
Displacement, cm ³ /rev [in ³ /rev]		199,8[12.19]	250,13[15.26]	315,7[19.26]	397[24.4]
Max. Speed,	Cont.	300	240	194	150
RPM	Int.*	375	300	240	190
Max. Torque	Cont.	45[4000]	54[4780]	55[4870]	61[5400]
daNm [lb-in]	Int.*	50[4425]	61[5400]	69[6110]	69[6110]
	Peak**	56[4960]	71[6280]	84[7435]	87[7770]
Max. Output	Cont.	11[4.8]	10[20.13.4]	9[12]	7,8[10.5]
kW [HP]	Int.*	13[17.4]	12[16.1]	10[13.4]	10,6[14.2]
Max. Pressure Drop	Cont.	175[2540]	175[2540]	135[1960]	110[1600]
bar [PSI]	Int.*	200[2900]	200[2900]	200[2900]	200[2900]
	Peak**	225[3260]	225[3260]	225[3260]	225[3260]
Max. Oil Flow	Cont.	60[15.8]	60[15.8]	60[15.8]	60[15.8]
lpm [GPM]	Int.*	75[19.8]	75[19.8]	75[19.8]	75[19.8]
Max. Inlet Pressure	Cont.	175[2540]	175[2540]	175[2540]	175[2540]
bar [PSI]	Int.*	200[2900]	200[2900]	200[2900]	200[2900]
	Peak**	225[3260]	225[3260]	225[3260]	225[3260]
Max. Return Pressure	Cont.	175[2540]	175[2540]	175[2540]	175[2540]
without Drain Line	Int.*	200[2900]	200[2900]	200[2900]	200[2900]
bar [PSI]	Peak**	225[3260]	225[3260]	225[3260]	225[3260]
Max. Starting Pressure		5[73]	4[58]	3[44]	3[44]
with Unloaded Shaft, bar [PSI]					
Min. Starting Torque	At max. press. drop Cont.	41[3630]	50[4425]	50[4425]	50[4425]
daNm [lb-in]	At max. press. drop Int.*	46[4070]	55[4870]	66[5840]	61[5400]
Min. Speed***, RPM		10	10	10	10
Weight, kg [lb] For					
rear port + 0,650 [1.433]	GR	8,1[18.9]	8,5[18.7]	9,2[20.3]	9,9[21.8]

Function Diagrams

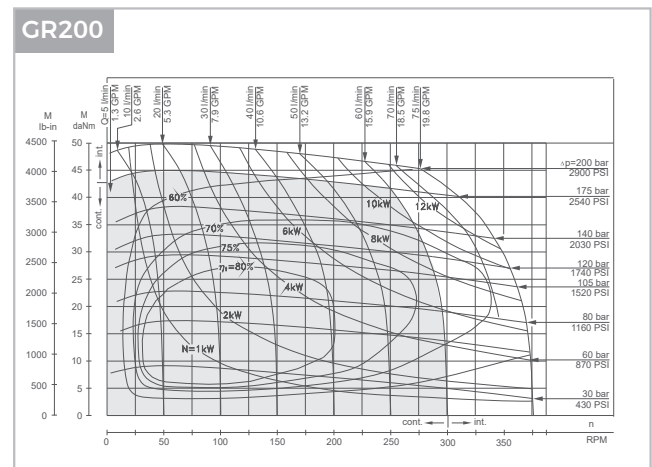
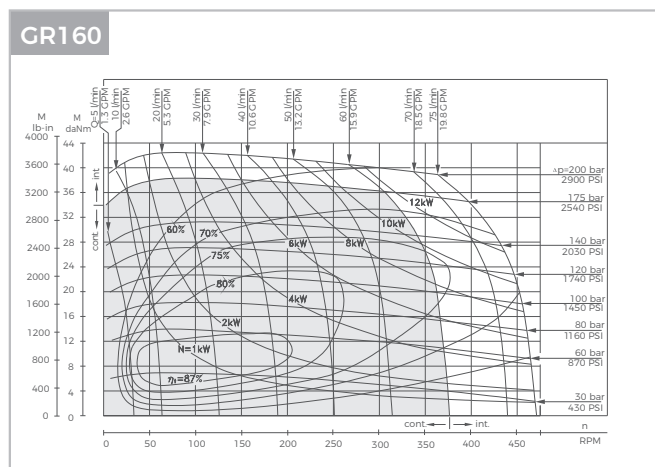
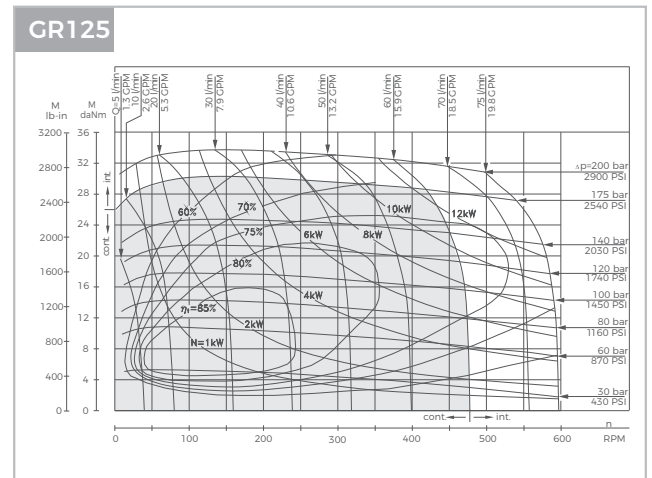
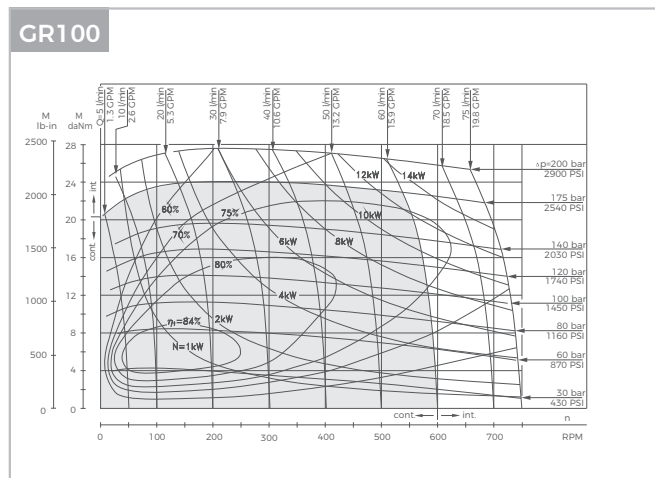
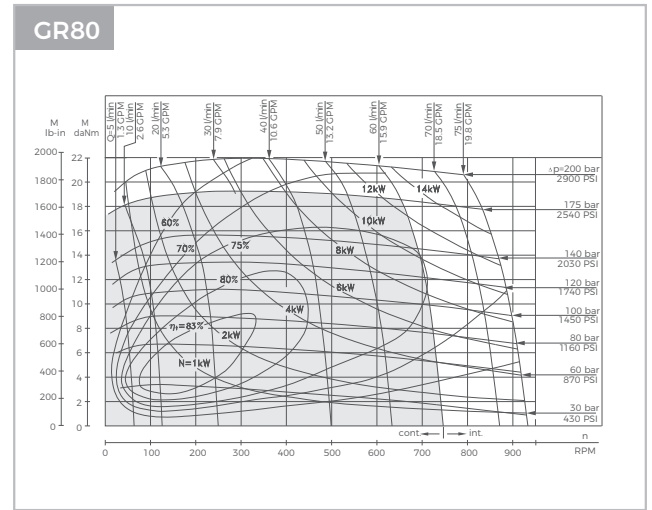
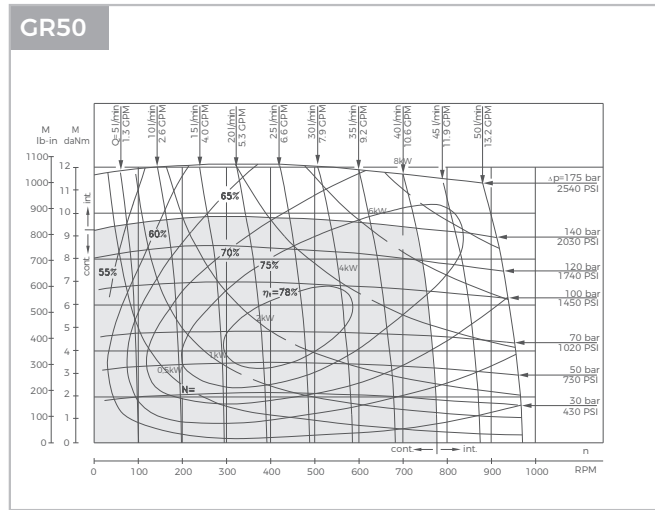

The function diagrams data is for average performance of randomly selected motors at backpressure. 5±10 bar [72.5÷145 PSI] and oil with viscosity of 32 mm²/s [150 SUS] at 50°C [122°F].

Function Diagrams

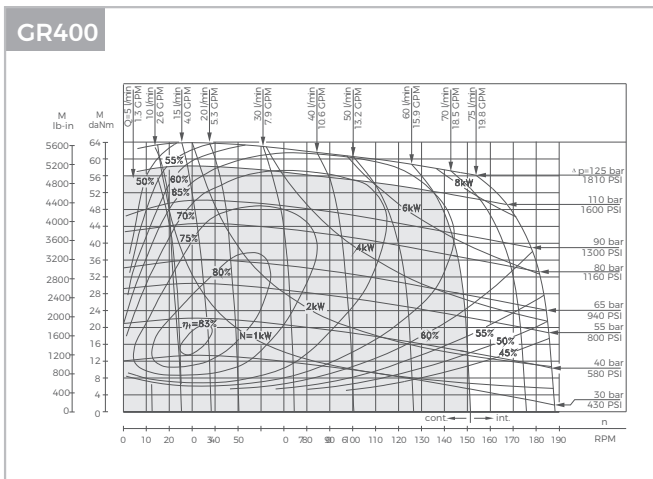
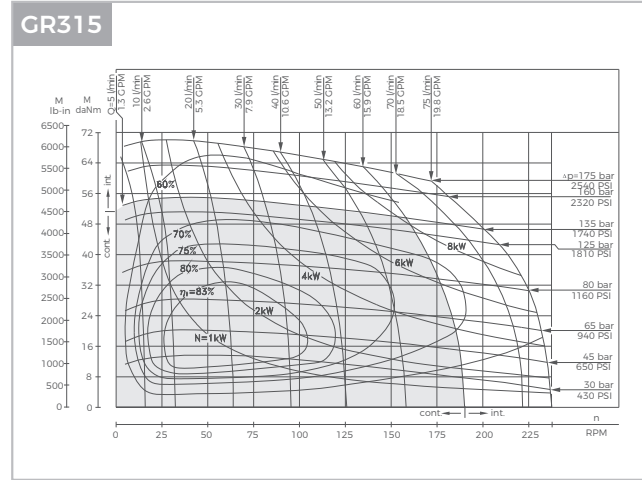
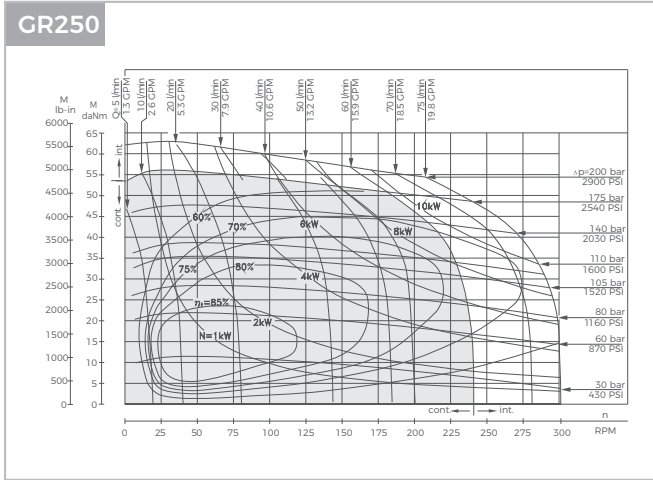

The function diagrams data is for average performance of randomly selected motors at backpressure. 5÷10 bar [72.5÷145 PSI] and oil with viscosity of 32 mm²/s [150 SUS] at 50°C [122°F].

GR Dimensions and Mountings

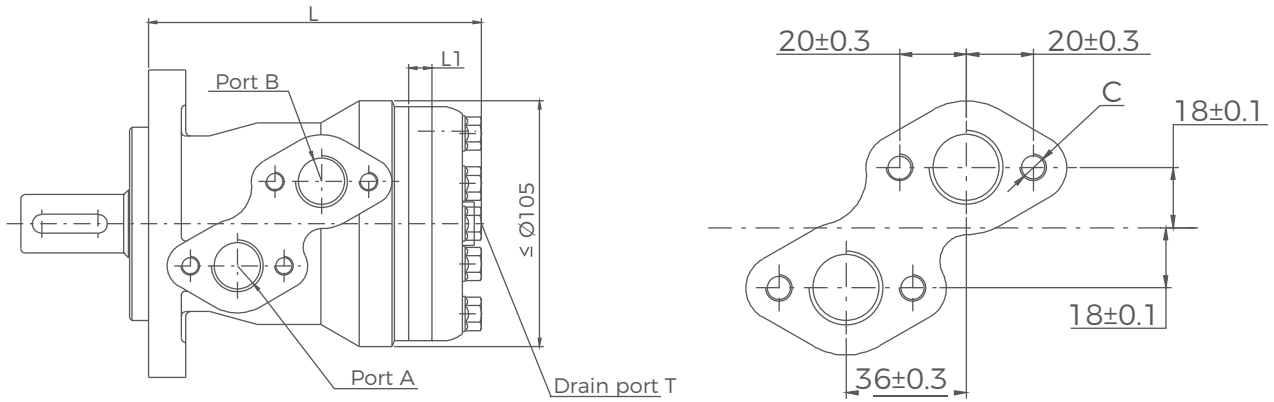

Model	L	L1
GR50	140	10
GR80	146	16
GR100	150	20
GR125	155	25
GR160	161.5	30.5
GR200	170	38.1
GR250	180	50
GR315	192	62
GR400	207	76

Mounting	G1 (depth)	M1 (depth)	U2 (depth)	U1 (depth)	G2 (depth)
P(A, B)	G1/2(15)	M22x1.5(15)	7/8-14 O-ring(17)	1/2-14NPTF(15)	PT(RC)1/2(15)
T	G1/4(12)	M14x1.5(12)	7/16-20UNF(12)	7/16-20UNF(12)	PT(RC)1/4(9.7)
C	4-M8(13)	4-M8(13)	4-5/16-18UNC(13)	4-5/16-18UNC(13)	4-M8(13)

GR Flange Covers Dimensions

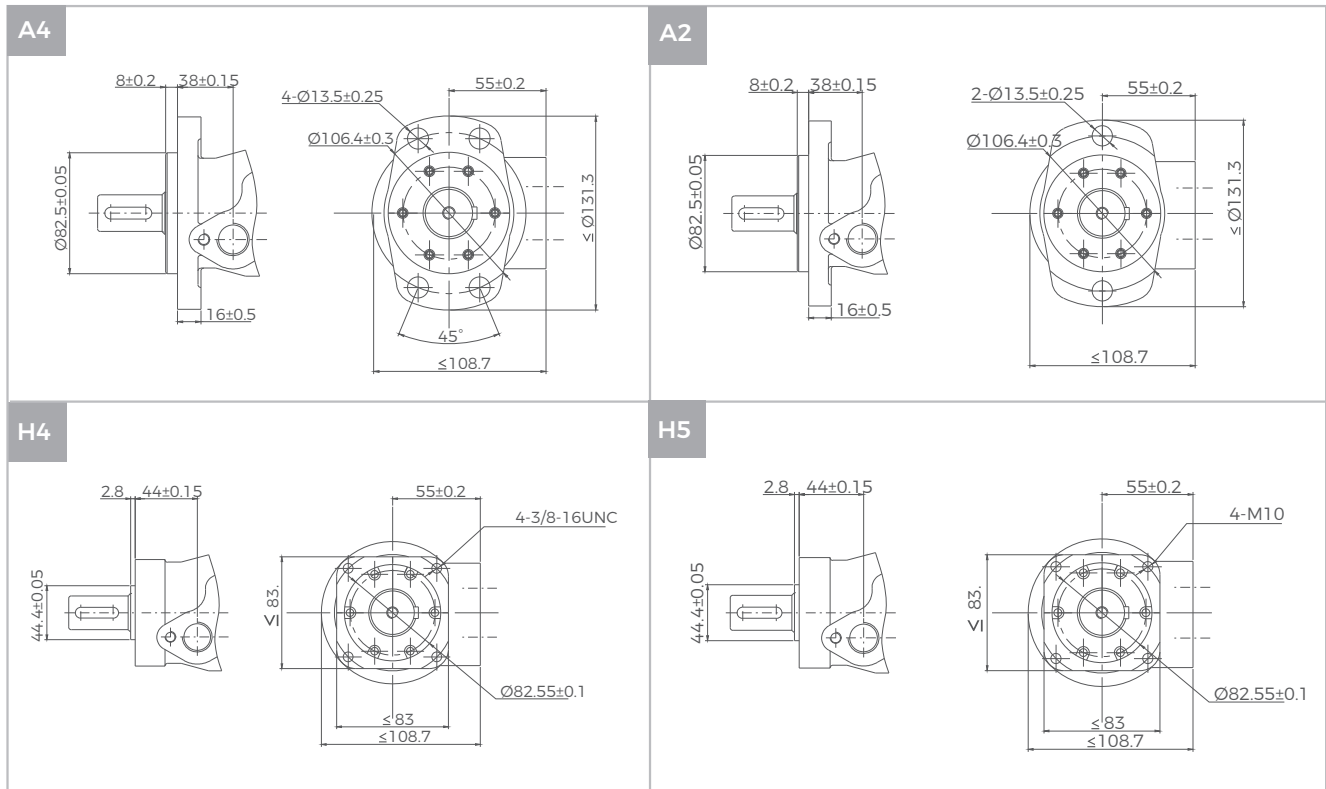

GR Shafts Dimensions

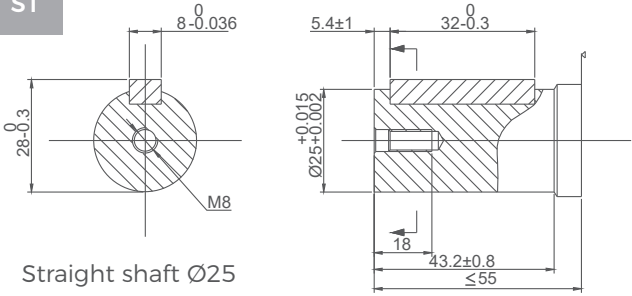
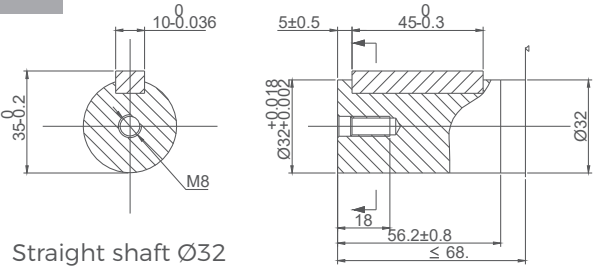
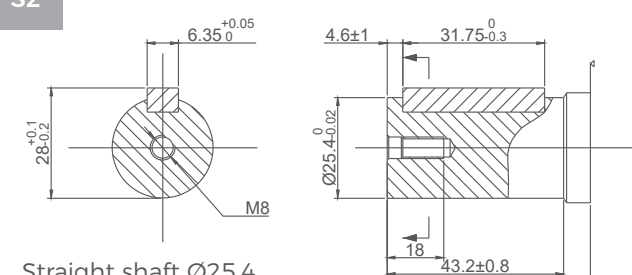
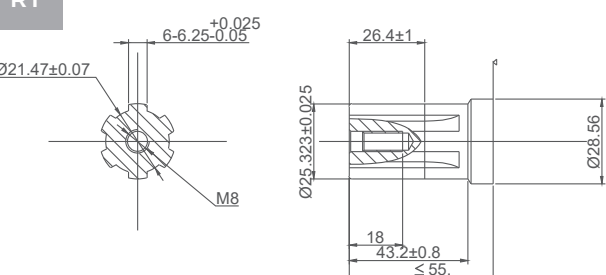
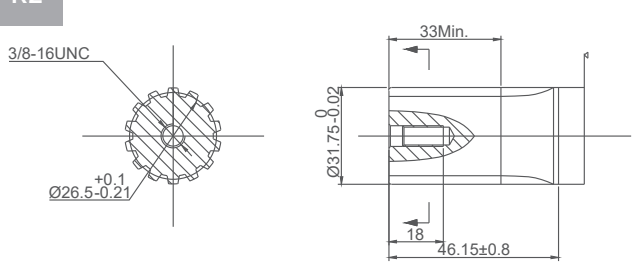
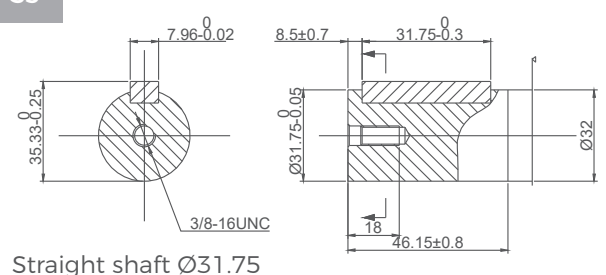
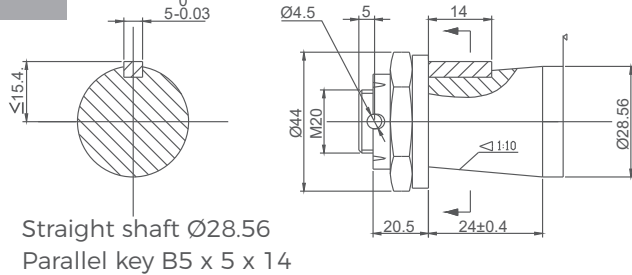
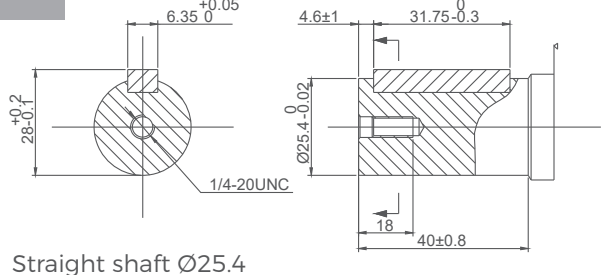
<p>S1</p>  <p>Straight shaft Ø25 Parallel key 8 x 7 x 32</p>	<p>S4</p>  <p>Straight shaft Ø32 Parallel key 10 x 8 x 45</p>
<p>S2</p>  <p>Straight shaft Ø25.4 Parallel key 6.35 x 6.35 x 31.75</p>	<p>R1</p>  <p>Splined shaft SAE 6B</p>
<p>R2</p>  <p>Splined shaft 14-DP 12/24</p>	<p>S5</p>  <p>Straight shaft Ø31.75 Parallel key 7.96 x 7.96 x 31.75</p>
<p>T1</p>  <p>Straight shaft Ø28.56 Parallel key B5 x 5 x 14 Tightening torque 100 ± 10Nm</p>	<p>S3</p>  <p>Straight shaft Ø25.4 Parallel key 6.35 x 6.35 x 31.75</p>

GR Series Hydraulic Motors

Permissible shaft seal pressure

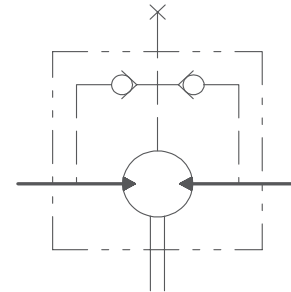
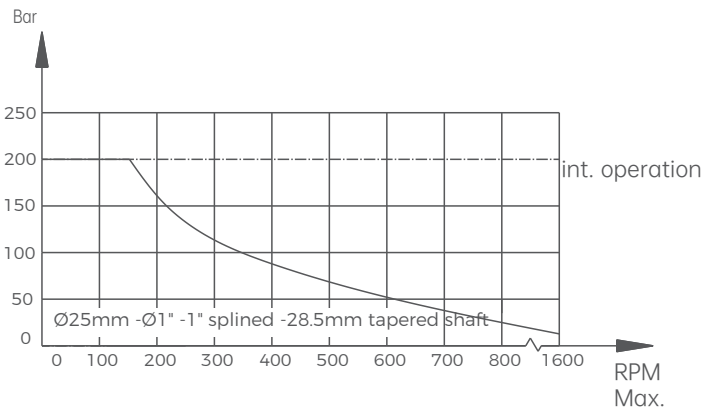

GR with standard shaft seal check valves and without use of drain connection: The pressure on the shaft seal never exceeds the pressure in the return line.

GR with standard shaft seal, check valves and with drain connection: The shaft seal pressure equals the pressure on the drain line.

Drain Port

In applications without drain line, output shaft seal exceeds a bit of the pressure in the return line. In applications using the drain line, the pressure of output shaft seal equals the pressure in drain line.

Standard direction of shaft rotation: Standard

When facing shaft end of motor, shaft to rotate:
Clockwise. When port "A" is pressurized.
Counter-clockwise port "B" is pressurized.

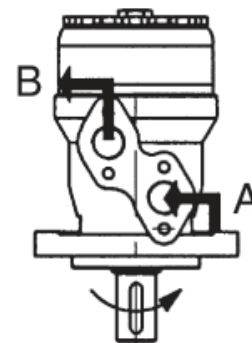

Output shaft stand radial force

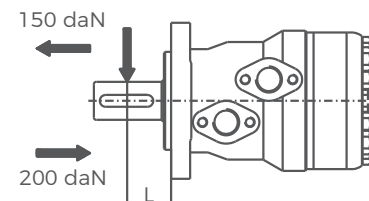
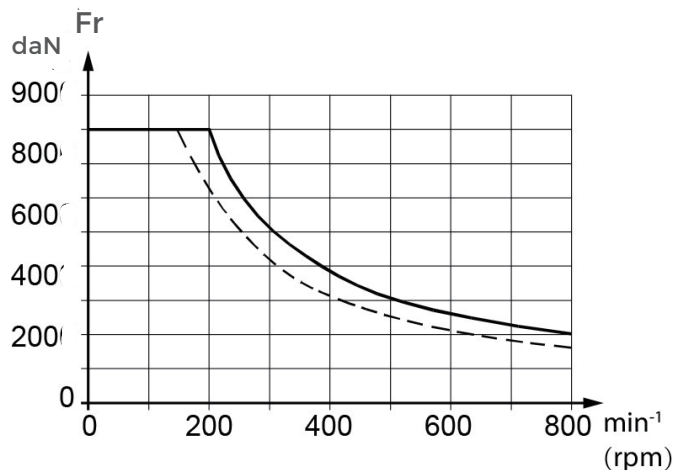

$$Fr = \frac{800}{n} * \frac{25000}{95 + L} \text{ (daN)}$$

Fr = Radial Force (daN)

L = Distance (mm)

n = Speed (rpm)

Rhomb-flange L = 30mm

Square-flange L = 24mm

GRS Series Hydraulic Motors

Options

- Flange connection
- Motor with needle bearing
- Side and rear ports
- Straight, splined and tapered shafts
- Shaft seal for high and low pressure
- Metric and BSPP ports
- Speed sensing
- Other special features

Applications

- Conveyors
- Feeding mechanism of robots and manipulators
- Metal working machines
- Textile machines
- Agricultural machines
- Food industries
- Lawn mower







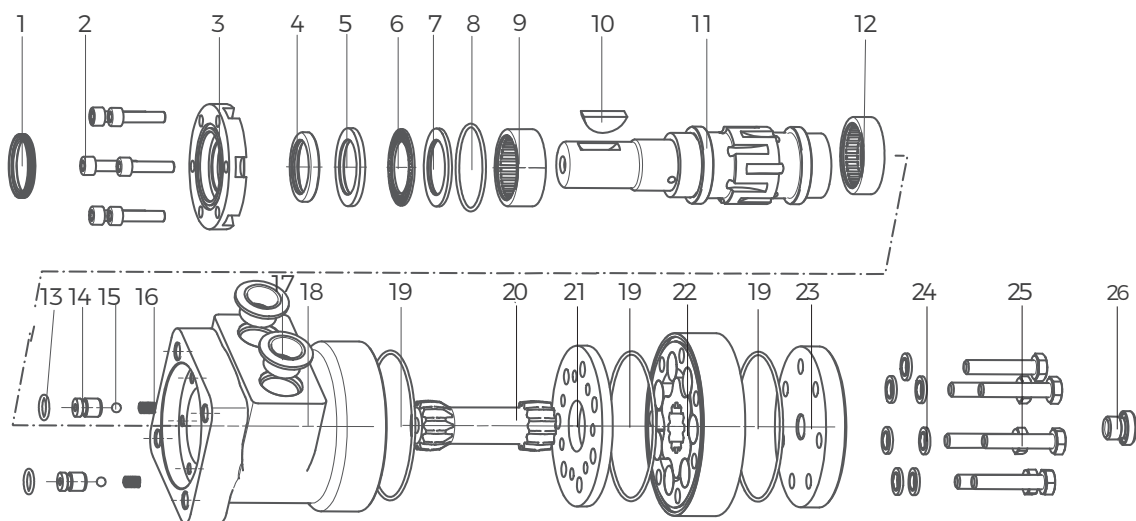







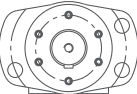

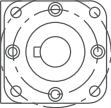
General

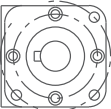
Max. Displacement	cm ³ /rev [in ³ /rev]	397 [24.4]
Max. Speed	RPM	970
Max. Torque	daNm [lb-in]	cont.: 61 [5400] int.: 69 [6100]
Max. Output	kW [HP]	15 [20.1]
Max. Pressure Drop	bar [PSI]	cont.: 175 [2540] int.: 200 [2900]
Max. Oil Flow	lpm [GPM]	75 [20]
Min. Speed	RPM	10
Operating Fluid		Mineral based- HLP (DIN 51524) or HM (ISO 6743/4)
Temperature Range	°C [°F]	-40÷140 [-40÷284]
Optimal Viscosity range	mm ² /s [SUS]	20÷75 [98÷347]
Filtration		ISO code: 20/16 (Min. recommended fluid filtration of 25 microns)



- | | | | | |
|------------------|-------------------------|--------------------------|------------------------------|------------------------|
| 1 Anti-dust ring | 6 Bearing | 11 Output shaft | 16 Spring | 21 Spacer |
| 2 Bolt | 7 Retainer | 12 Needle roller bearing | 17 Oil-resistant rubber plug | 22 Stator assembly |
| 3 Front Cover | 8 O-ring seal | 13 O-ring seal | 18 Housing | 23 Rear cover |
| 4 Shaft seal | 9 Needle roller bearing | 14 Check valve | 19 O-ring seal | 24 Washer |
| 5 Retainer | 10 woodruff key | 15 Steel ball | 20 Transmission shaft | 25 Bolt |
| | | | | 26 External drain plug |

Ordering Code

GRS SERIES		DISP		FLANGE		SHAFT		PORTS		ROTATION		PAINT		FUNCTION	
CODE	DISP	CODE	FLANGE	CODE	PORTS	CODE	SHAFT	CODE	PAINT	CODE	FUNCTION	CODE	ROTATION		
50	51.5cm ³ /rev [3.14in ³ /rev]	A2	2-Hole SAE A, pilot Ø82.5×2.8 	G7	G1/2, G1/4	S6	Ø25.4, woodruff key Ø25.4 × 6.35 	A	No Paint	A	Standard				
80	80.3cm ³ /rev [4.90in ³ /rev]	A3	4-Hole SAE A, pilot Ø82.5×2.8 	U9	7/8-14UNF O-ring, 7/16-20UNF	R4	Ø25.4, splined tooth SAE 6B 	B	Blue	N	Big radial force				
100	99.8cm ³ /rev [6.09in ³ /rev]	H4	4-Hole square, pilot Ø44.4×2.8 	UA	1/2-14NPTF, 7/16-20UNF	S7	Ø25.4, parallel key 8×7 ×32 	C	Black	D	No case drain				
125	125.7cm ³ /rev [7.67in ³ /rev]	H5	4-Hole square, pilot Ø44.4×2.8 	G8	PT(Rc) 1/2, PT(Rc) 1/4	S8	Ø25.4, parallel key 6.35×6.35×31.75 	S	Silver grey	F	Free running				
160	159.6cm ³ /rev [9.74in ³ /rev]			D1	Ø10 O-ring, 7/16-20UNF manifold 4×5/16-18UNC	S9	Ø25.4, pin hole Ø10.3 			L	Low speed				
200	199.8cm ³ /rev [12.19in ³ /rev]			D2	Ø10 O-ring, G1/4 manifold 4×M8	SA	Ø25.4, pin hole Ø8 			V	High temp.				
250	250.1cm ³ /rev [15.26in ³ /rev]			M2	M18×1.5, M10×1	SB	Ø22.2, parallel key 6.35×6.35×25.4 			S	Low temp.				
315	315.7cm ³ /rev [19.26in ³ /rev]			M3	M20×1.5, M10×1	R5	Ø22.2, splined tooth 13-DP 16/32 								
400	397cm ³ /rev [24.4in ³ /rev]			M4	M22×1.5, M10×1	T3	Tapered shaft Ø25.4 woodruff key Ø25.4×6.35 								
						SC	Ø25, parallel key 8×7×32 								
						SD	Ø25, parallel key 7×7×32 								

Specifications

Type		GRS50	GRS80	GRS100	GRS125	GRS160
Displacement, cm ³ /rev [in ³ /rev]	Cont.	51,5[3.14]	80,3[4.90]	99,8[6.09]	125,7[7.67]	159,6[9.74]
Max. Speed,	Int.*	775	750	600	457	375
RPM	Cont.	970	940	750	600	470
Max. Torque	Int.*	10[900]	20[1770]	24[2125]	30[2655]	39[3450]
daNm [lb-in]	Peak**	13[1150]	22[1947]	28[2480]	34[3010]	43[3805]
	Cont.	17[1505]	27[2390]	32[2832]	37[3275]	46[4070]
Max. Output	Int.*	7[9.5]	125[17]	13[17.4]	125[16.8]	115[15.4]
kW [HP]	Cont.	85[11.9]	15[20.1]	15[20.1]	145[19.5]	14[18.8]
Max. Pressure Drop	Int.*	140[2030]	175[2540]	175[2540]	175[2540]	175[2540]
bar [PSI]	Peak**	175[2540]	200[2900]	200[2900]	200[2900]	200[2900]
	Cont.	225[3260]	225[3260]	225[3260]	225[3260]	225[3260]
Max. Oil Flow	Int.*	40[10.5]	60[15.8]	60[15.8]	60[15.8]	60[15.8]
lpm [GPM]	Cont.	50[13.2]	75[19.8]	75[19.8]	75[19.8]	75[19.8]
Max. Inlet Pressure	Int.*	175[2540]	175[2540]	175[2540]	175[2540]	175[2540]
bar [PSI]	Peak**	200[2900]	200[2900]	200[2900]	200[2900]	200[2900]
	Cont.	225[3260]	225[3260]	225[3260]	225[3260]	225[3260]
Max. Return Pressure	Int.*	175[2540]	175[2540]	175[2540]	175[2540]	175[2540]
without Drain Line	Peak**	200[2900]	200[2900]	200[2900]	200[2900]	200[2900]
bar [PSI]		225[3260]	225[3260]	225[3260]	225[3260]	225[3260]
Max. Starting Pressure		10[145]	10[145]	10[145]	9[130]	7[102]
with Unloaded Shaft, bar [PSI]						
Min. Starting Torque	At max. press. drop Cont.	8[710]	15[1330]	20[1770]	25[2215]	32[2832]
daNm [lb-in]	At max. press. drop Int.*	10[885]	17[1505]	23[2035]	28[2480]	37[3275]
Min. Speed***, RPM		10	10	10	10	10
Weight, kg [lb] For rear port + 0,650 [1.433]	GRS	6,9[15.2]	7[15.4]	7,3[16.1]	7,4[16.3]	7,6[15.4]

Specifications

Type		GRS200	GRS250	GRS315	GRS400
Displacement, cm ³ /rev [in ³ /rev]	Cont.	199,8[12.19]	250,1[15.26]	315,7[19.26]	397[24.4]
Max. Speed,	Int.*	300	240	190	150
RPM	Cont.	375	300	240	190
Max. Torque	Int.*	45[4000]	54[4780]	55[4870]	61[5400]
daNm [lb-in]	Peak**	50[4425]	61[5400]	69[6110]	69[6110]
	Cont.	56[4960]	71[6280]	84[7435]	87[7700]
Max. Output	Int.*	11[14.8]	10[13.4]	9[12]	78[10.5]
kW [HP]	Cont.	13[17.4]	12[16.1]	10[13.4]	106[14.2]
Max. Pressure Drop	Int.*	175[2540]	175[2540]	135[1960]	110[1600]
bar [PSI]	Peak**	200[2900]	200[2900]	175[2540]	140[2030]
	Cont.	225[3260]	225[3260]	225[3260]	225[3260]
Max. Oil Flow	Int.*	60[15.8]	60[15.8]	60[15.8]	60[15.8]
lpm [GPM]	Cont.	75[19.8]	75[19.8]	75[19.8]	75[19.8]
Max. Inlet Pressure	Int.*	175[2540]	175[2540]	175[2540]	175[2540]
bar [PSI]	Peak**	200[2900]	200[2900]	200[2900]	200[2900]
	Cont.	225[3260]	225[3260]	225[3260]	225[3260]
Max. Return Pressure	Int.*	175[2540]	175[2540]	175[2540]	175[2540]
without Drain Line	Peak**	200[2900]	200[2900]	200[2900]	200[2900]
bar [PSI]		225[3260]	225[3260]	225[3260]	225[3260]
Max. Starting Pressure					
with Unloaded Shaft, bar [PSI]		5[73]	4[58]	3[44]	3[44]
Min. Starting Torque	At max. press. drop Cont.	41[3630]	50[4425]	50[4425]	50[4425]
daNm [lb-in]	At max. press. drop Int.*	46[4070]	55[4870]	66[5840]	61[5400]
Min. Speed***, RPM		10	10	10	10
Weight, kg [lb] For					
rear port + 0,650 [1.433]	GRS	8,1[18.9]	8,5[18.7]	9,2[20.3]	9,9[21.8]

Function Diagrams

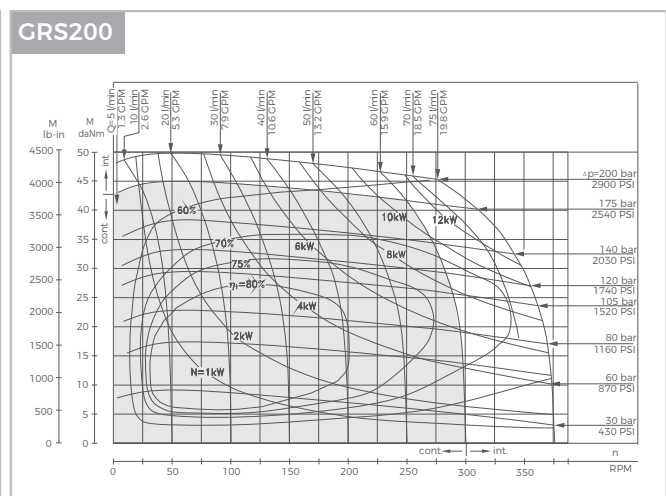
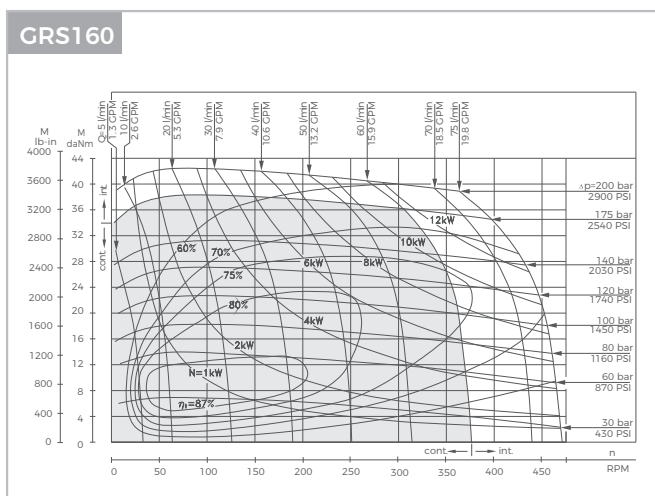
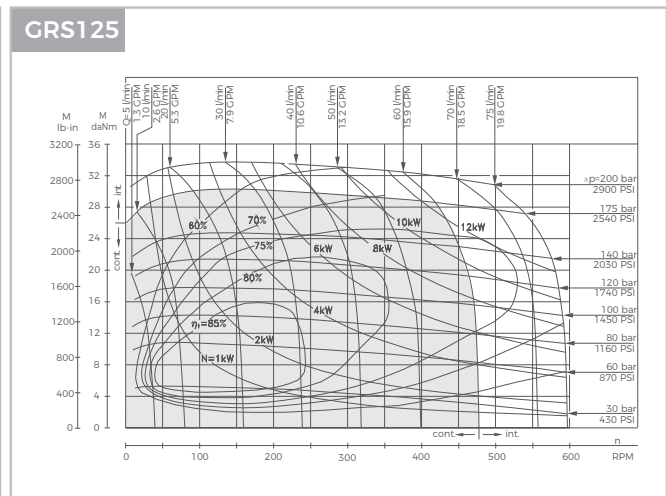
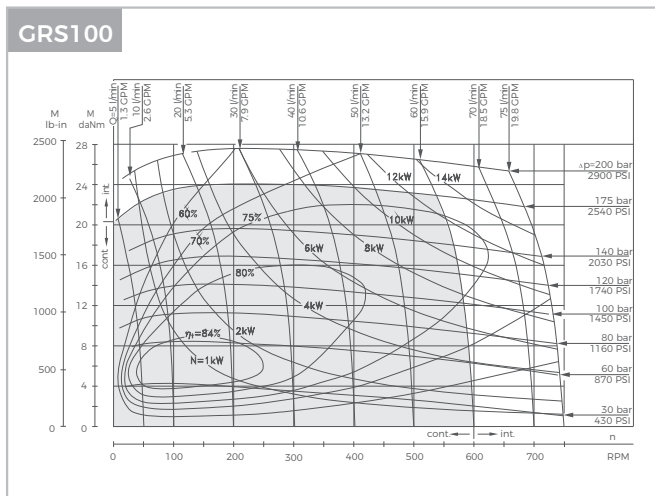
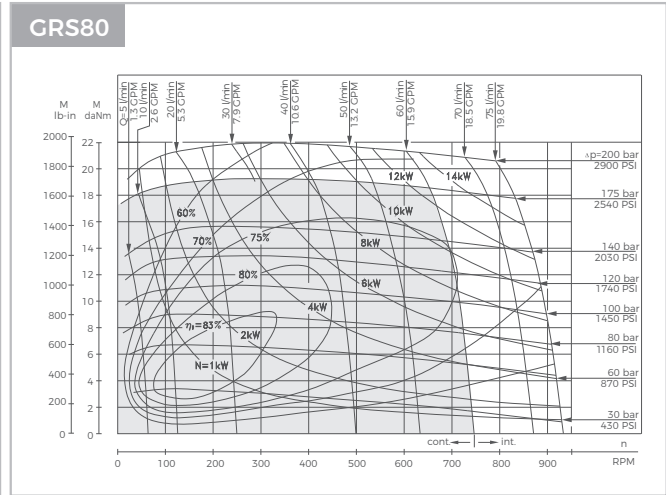
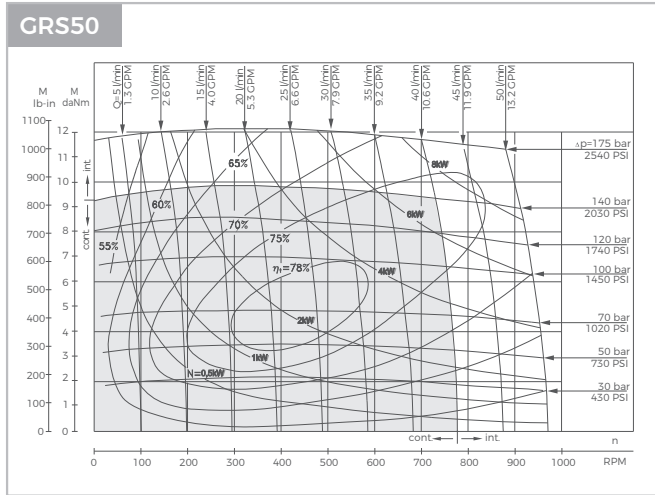

The function diagrams data is for average performance of randomly selected motors at backpressure. 5÷10 bar [72.5÷145 PSI] and oil with viscosity of 32 mm²/s [150 SUS] at 50°C [122°F].

Function Diagrams

GR250

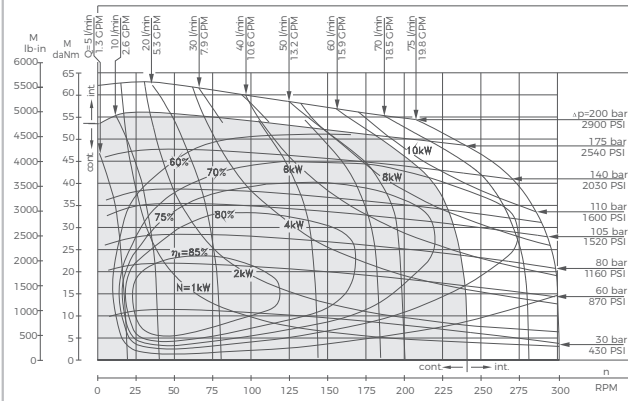

GRS315

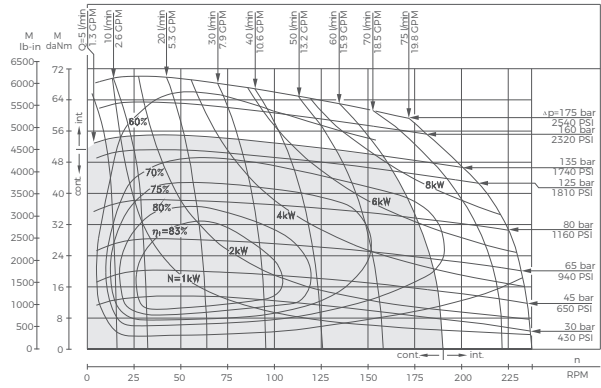

GRS400

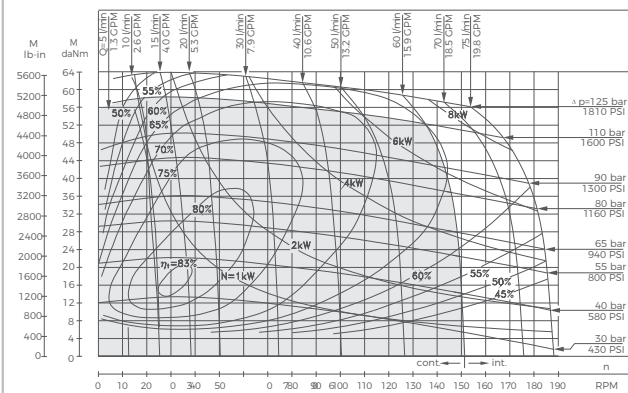

The function diagrams data is for average performance of randomly selected motors at backpressure. 5÷10 bar [72.5÷145 PSI] and oil with viscosity of 32 mm²/s [150 SUS] at 50°C [122°F].

GRS Dimensions and Mountings

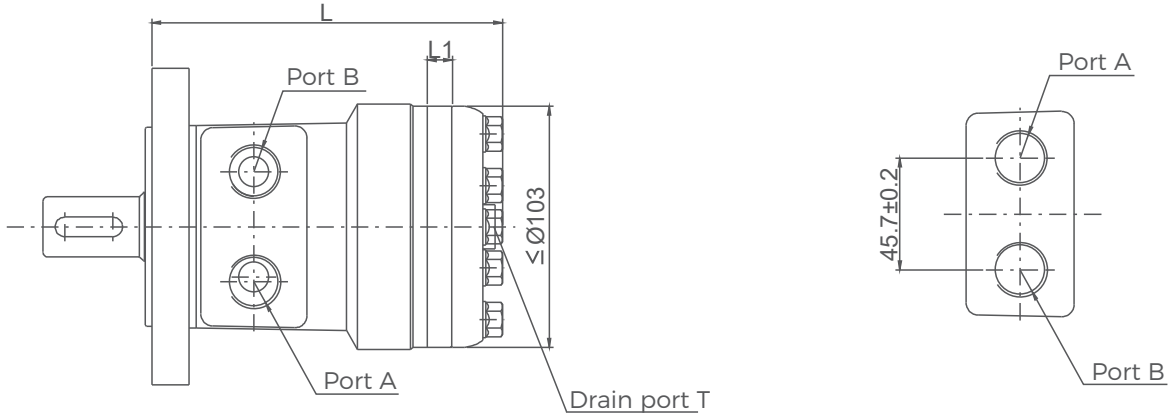

Model	L	L1
GRS50	146	10
GRS80	152	16
GRS100	156	20
GRS125	161	25
GRS160	166.5	30.5
GRS200	174	38.1
GRS250	186	50
GRS315	198	62
GRS400	213	76

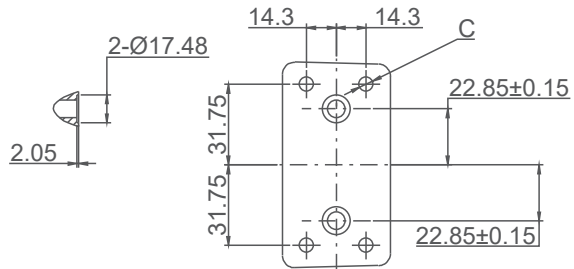

Mounting	G7 (depth)	U9 (depth)	UA (depth)	G8 (depth)	M2 (depth)	M3 (depth)	M4 (depth)	D1 (depth)	D2 (depth)
P(A, B)	G1/2(15)	7/8-14 O-ring(17)	1/2-14NPTF(15)	PT(RC)1/2(15)	M18 x 1.5(15)	M20 x 1.5(15)	M22 x 1.5(15)	10	10
T	G1/4(12)	7/16-20UNF(12)	7/16-20UNF(12)	PT(RC)1/4(9.7)	M10 x 1(12)	M10 x 1(12)	M10 x 1(12)	7/16-20UNF(12)	G1/4(12)
C	—	—	—	—	—	—	—	4-5/16-18UNC(13)	4-M8(13)

GRS Flange Covers Dimensions

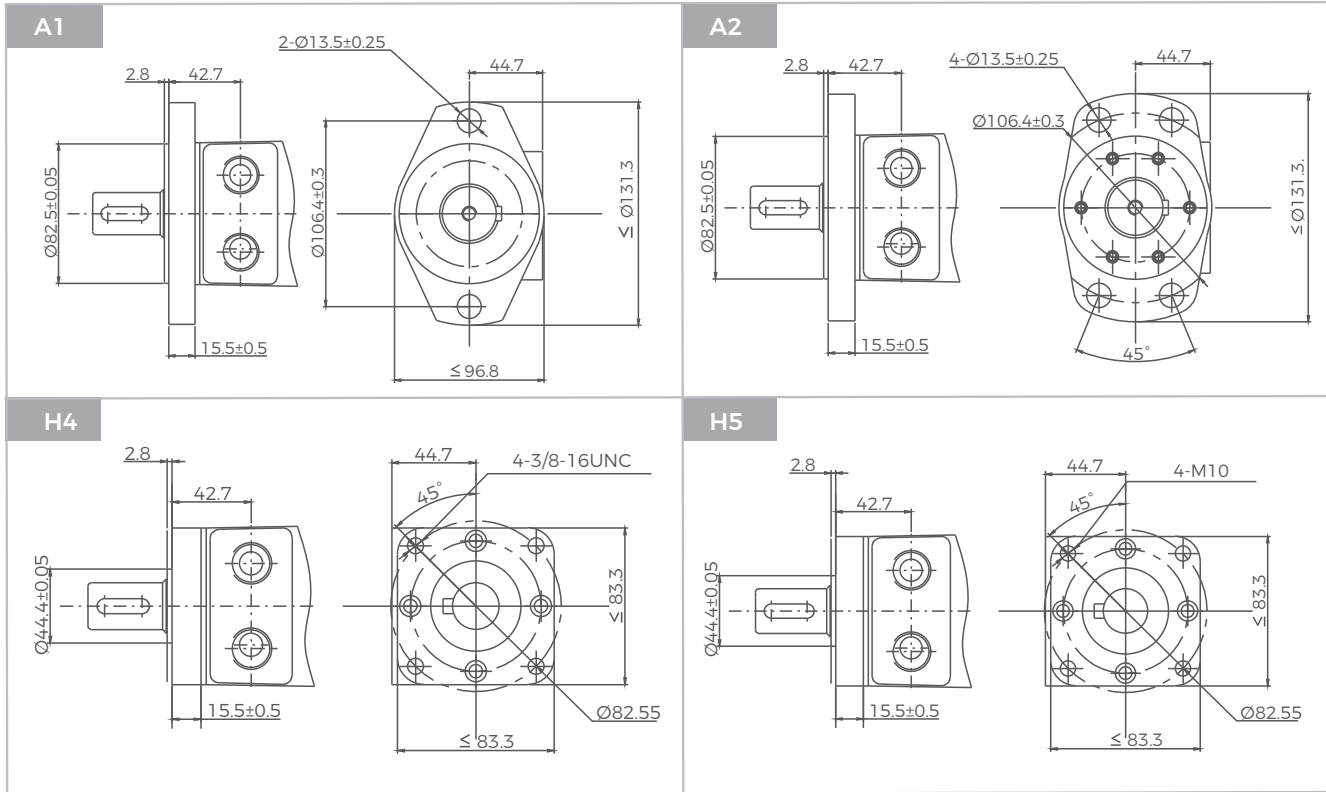

GRS Shafts Dimensions

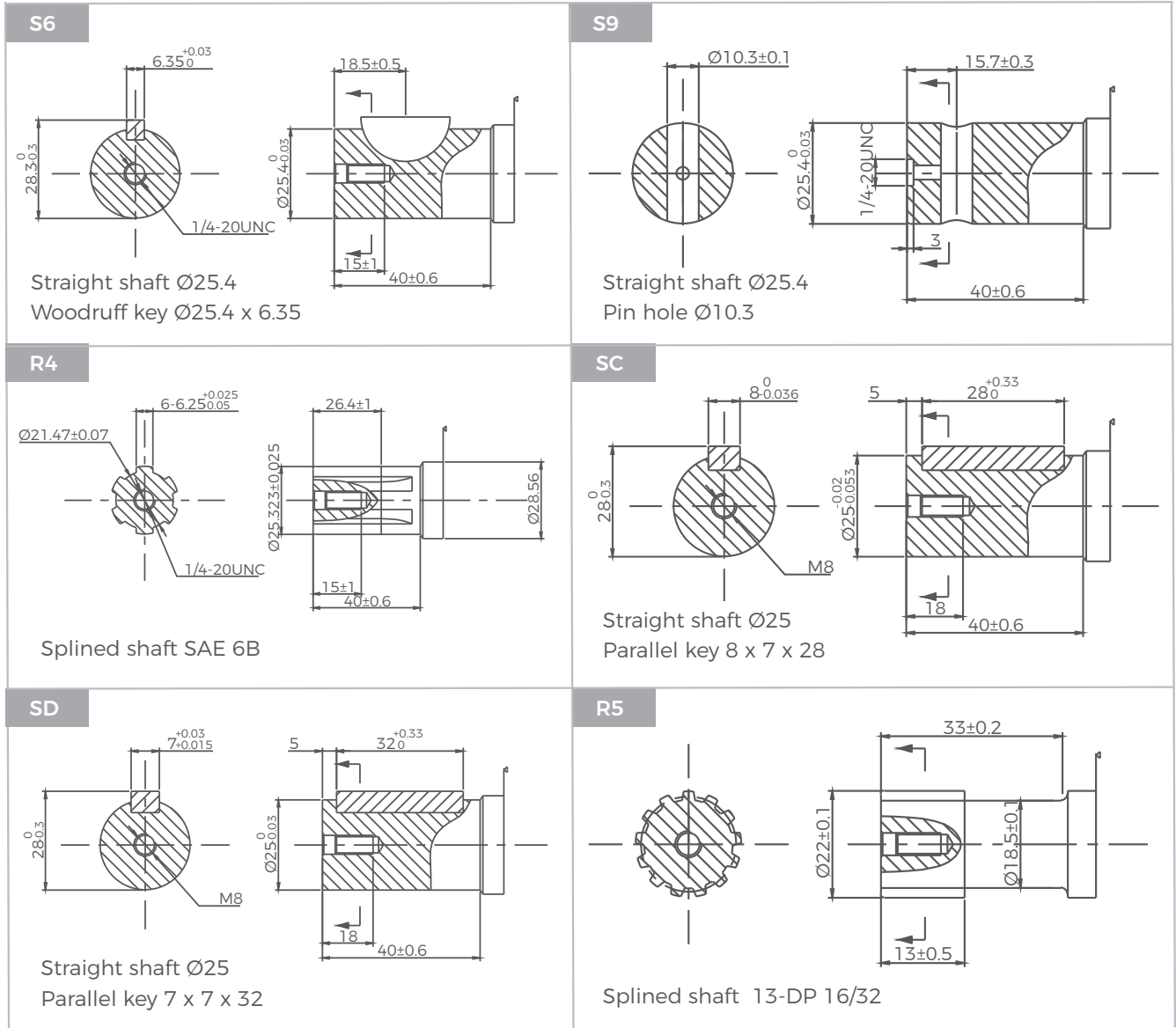

GRS Shafts Dimensions

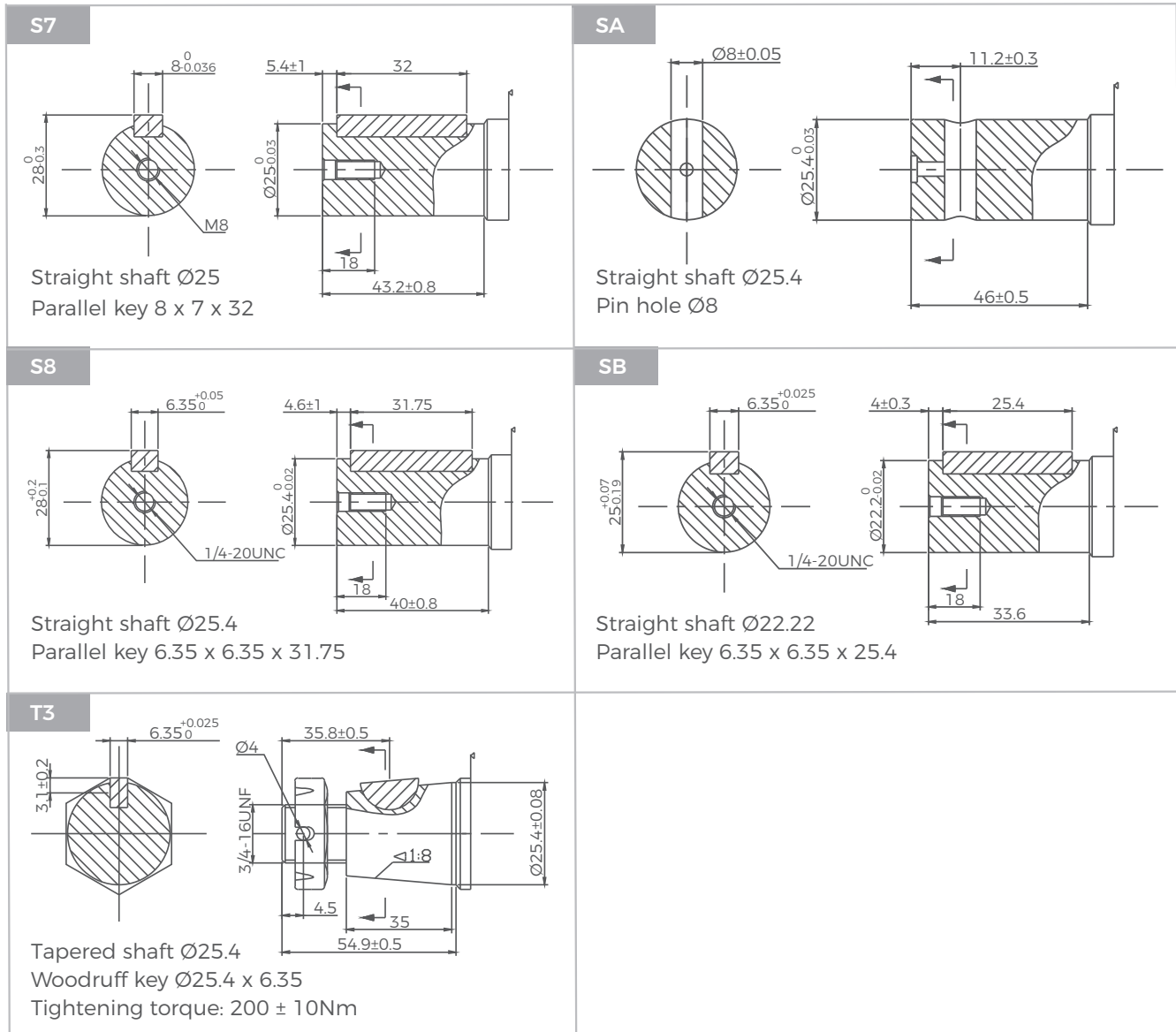

GRS Series Hydraulic Motors

Permissible shaft seal pressure

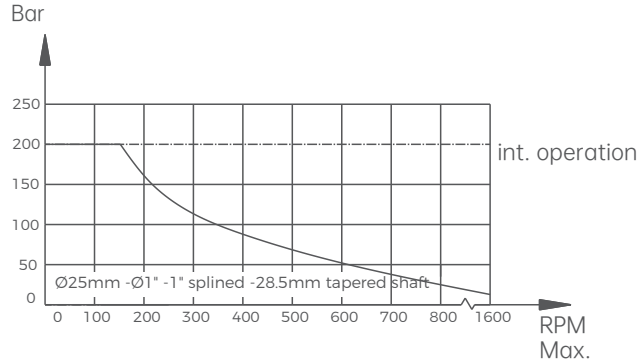

Drain Port

In applications without drain line, output shaft seal exceeds a bit of the pressure in the return line. When applications use the drain line, the pressure of output shaft seal equals the pressure in drain line.

Standard direction of shaft rotation: Standard

When facing shaft end of motor, shaft to rotate:
Clockwise when port "A" is pressurized.
Counter-clockwise port "B" is pressurized.

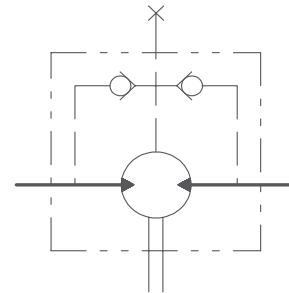

GRS with standard shaft seal, check valves and without use of drain connection: The pressure on the shaft seal never exceeds the pressure in the return line.
GRS with standard shaft seal, check valves and with drain connection: The shaft seal pressure equals the pressure on the drain line.

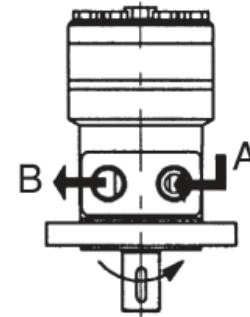

Output shaft stand radial force

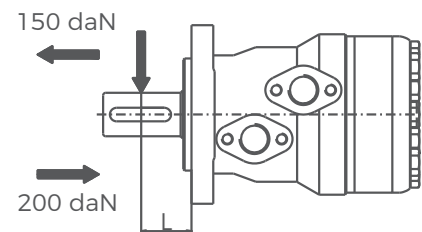
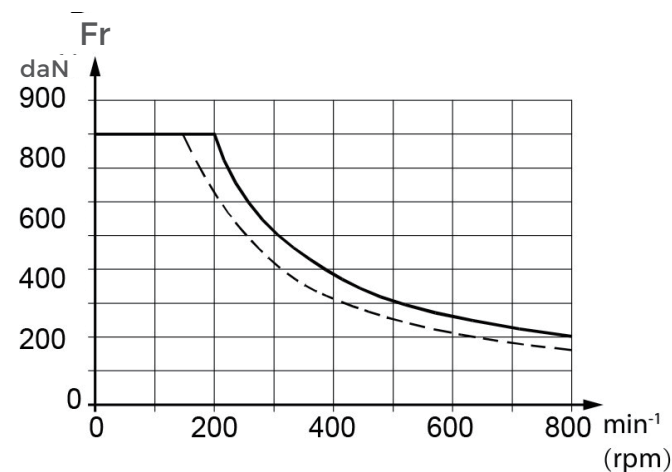

$$Fr = \frac{800}{n} * \frac{25000}{95 + L} \text{ (daN)}$$

Fr = Radial Force (daN)

L = Distance (mm)

n = Speed (rpm)

Rhomb-flange L = 30mm

Square-flange L = 24mm

GH Series Hydraulic Motors

Options

- Flange connection
- Straight, splined and tapered shafts
- Metric and BSPP ports
- Other special features

Applications

- Conveyors
- Feeding mechanism of robots and manipulators
- Metal working machines
- Textile machines
- Agricultural machines
- Food industries
- Mining machines



General

Max. Displacement	cm ³ /rev [in ³ /rev]	502,4 [30.7]
Max. Speed	RPM	445
Max. Torque	daNm [lb-in]	cont.: 84 [7434] int.: 104 [9204]
Max. Output	kW [HP]	18,5 [24.8]
Max. Pressure Drop	bar [PSI]	cont.: 175 [2540] int.: 200 [2900]
Max. Oil Flow	lpm [GPM]	90 [23.78]
Min. Speed	RPM	5
Pressure fluid		Mineral based- HLP (DIN 51524) or HM (ISO 6743/4)
Temperature Range	°C [°F]	-40÷140 [-40÷284]
Optimal Viscosity range	mm ² /s [SUS]	20÷75 [98÷347]
Filtration		ISO code: 20/16 (Min. recommended fluid filtration of 25 microns)

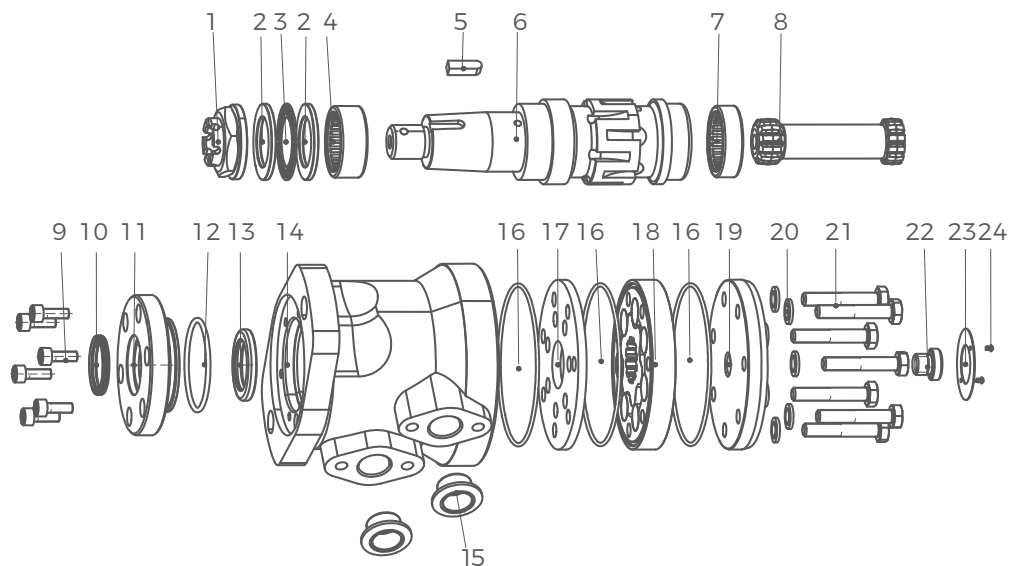





- 1 Slotted nuts
- 2 Bearing retainer
- 3 Thrust needle roller bearing
- 4 Needle roller bearings
- 5 Parallel Key
- 6 Output shaft

- 7 Thrust needle roller bearing
- 8 Transmission shaft
- 9 Screw
- 10 Skeleton anti-dust ring
- 11 Front cover
- 12 O-ring

- 13 Pressure Resistant Oil Seal
- 14 Housing
- 15 Oil port plug cap
- 16 O-ring
- 17 Spacer
- 18 Rotor and stator

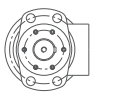
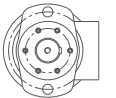
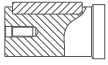
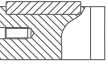
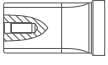
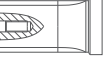
- 19 Rear cover
- 20 Washer
- 21 Rear cover bolts
- 22 Plug
- 23 Nameplate
- 24 Rivets

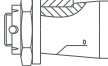
Ordering Code

GH SERIES		DISP	FLANGE		SHAFT	PORTS		ROTATION	PAINT	FUNCTION	
CODE		DISP	CODE	FLANGE	CODE	PORTS		CODE	PAINT	CODE	ROTATION
200		201.3cm ³ /rev [12.9in ³ /rev]	A5	2- Ø13.5 SAE A pilot Ø82.5×6 	G1	G1/2, G1/4 Manifold 4×M8		A	No paint	A	Standard
250		252cm ³ /rev [15.4in ³ /rev]			M1	M22×1.5, M14×1.5 Manifold 4×M8		B	Blue	R	Opposite
315		314.9cm ³ /rev [19.2in ³ /rev]			A6	4- Ø13.5 SAE A pilot Ø82.5×6 	U2	7/8-14UNF O-ring, 7/16-20UNF Manifold 4×5/16-18UNC		C	Black
400		396.8cm ³ /rev [24.2in ³ /rev]	U1	1/2-14 NPTF, 7/16-20UNF Manifold 4×5/16-18UNC			S	Silver grey			
500		502.4cm ³ /rev [30.7in ³ /rev]	G2	PT (Rc) 1/2, PT (Rc) 1/4 Manifold 4×M8							
					CODE	SHAFT				CODE	FUNCTION
					S4	Ø32 parallel key 10×8×45 				A	Standard
					SF	Ø35 parallel key 10×8×45 				N	Big radial force
					R3	Ø31.75 splined tooth 14-DP 12/24 				D	No drain
					R6	Long Ø31.75 splined tooth 14-DP 12/24 				F	Free running
					SG	Ø31.5 parallel key 7.96×7.96×31.75 				L	Low speed
					T4	Tapered Ø35 parallel key B6×6×20 				V	High temp.
					R4	Ø25.4 SAE 6B 				S	Low temp.
					SH	Ø35 parallel key 10×8×45 					

Specifications

Type		GH200	GH250	GH315	GH400	GH500
Displacement, cm ³ /rev [in ³ /rev]		201,3[12.3]	252[15.4]	314,9[19.2]	396,8[24.2]	502,4[30.7]
Max. Speed,	Cont.	370	295	235	185	150
RPM	Int.*	445	350	285	225	180
Max. Torque	Cont.	51[4510]	61[5398]	74[6548]	84[7434]	82[7257]
daNm [lb-in]	Int.*	58[5130]	70[6195]	82[7257]	98[8673]	104[9204]
	Peak**	64[5064]	79[6992]	98[8673]	109[9647]	117[10350]
Max. Output	Cont.	16[21]	16[21]	14[18.7]	12,5[16.7]	11[14.7]
kW [HP]	Int.*	18,5[24.8]	18,5[24.8]	15,5[20.7]	15[20.1]	14[18.7]
Max. Pressure Drop	Cont.	175[2540]	175[2540]	175[2540]	155[2240]	125[1810]
bar [PSI]	Int.*	200[2900]	200[2900]	200[2900]	190[2750]	160[2320]
	Peak**	225[3260]	225[3260]	225[3260]	210[3045]	180[2610]
Max. Oil Flow	Cont.	75[19.81]	75[19.81]	75[19.81]	75[19.81]	75[19.81]
lpm [GPM]	Int.*	90[23.78]	90[23.78]	90[23.78]	90[23.78]	90[23.78]
Max. Inlet Pressure	Cont.	200[2900]	200[2900]	200[2900]	200[2900]	200[2900]
bar [PSI]	Int.*	225[3260]	225[3260]	225[3260]	225[3260]	225[3260]
	Peak**	250[3626]	250[3626]	250[3626]	250[3626]	250[3626]
Max. Starting Pressure with Unloaded Shaft, bar [PSI]		5[72]	5[72]	5[72]	5[72]	5[72]
Min. Starting Torque	At max. press. drop Cont.	39[3450]	52[4600]	66[5840]	72[6370]	72[6370]
daNm [lb-in]	At max. press. drop Int.*	45[3980]	59[5221]	73[6460]	88[7788]	88[7788]
Min. Speed**, RPM		10	10	8	5	5
Weight, kg [lb]	GH	10,5[23.2]	11[24.3]	11,5[25.4]	12,3[27.1]	13[28.7]

Function Diagrams

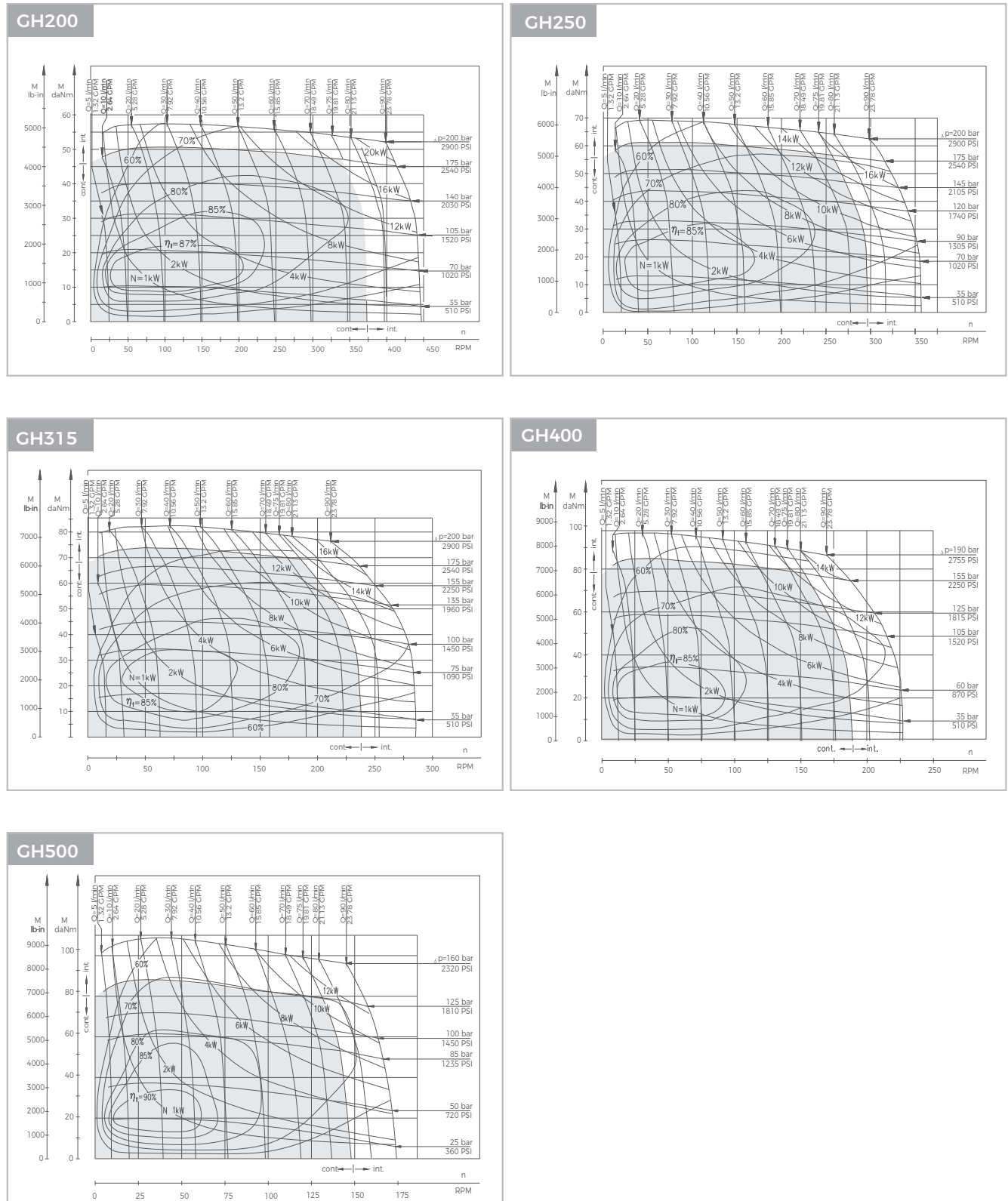

The function diagrams data is for average performance of randomly selected motors at backpressure. 5÷10 bar [72.5÷145 PSI] and oil with viscosity of 32 mm²/s [150 SUS] at 50°C [122°F].

GH Dimensions and Mountings

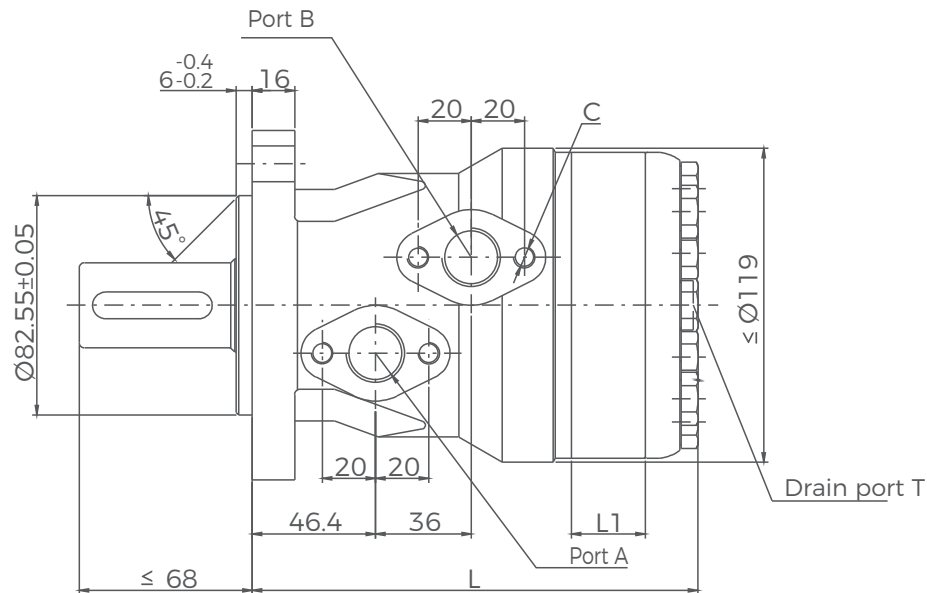

Model	L	L1
GH200	168	27
GH250	175	34
GH315	184	42
GH400	195	54
GH500	206	65

Mounting	G1 (depth)	M1 (depth)	U2 (depth)	U1 (depth)	G2 (depth)
P(A, B)	G1/2(15)	M22 x1.5(15)	7/8-14 O-ring(17)	1/2-14 NPTF(15)	PT(RC)1/2(15)
T	4-M8(13)	4-M8(13)	4-5/16-18 UNC(13)	4-5/16-18 UNC(13)	4-M8(13)
C	G1/4(12)	M14 x 1.5(12)	7/16-20 UNF(12)	7/16-20 UNF(12)	PT(RC)1/4(9.7)

GH Flange Covers Dimensions

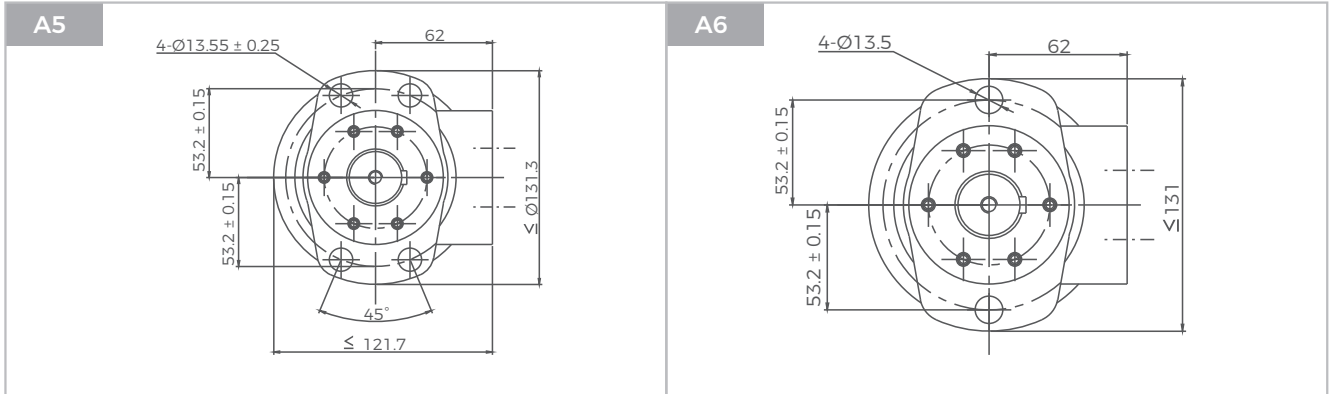

GH Shafts Dimensions

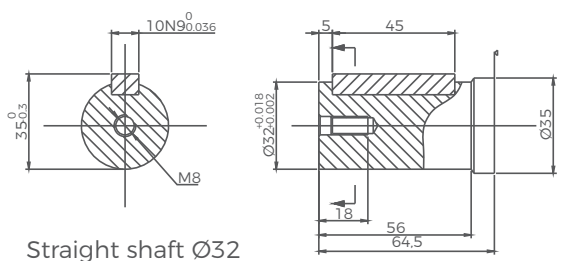
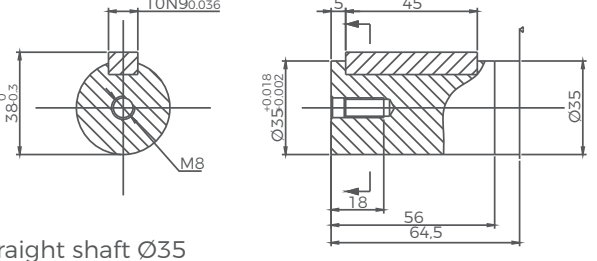
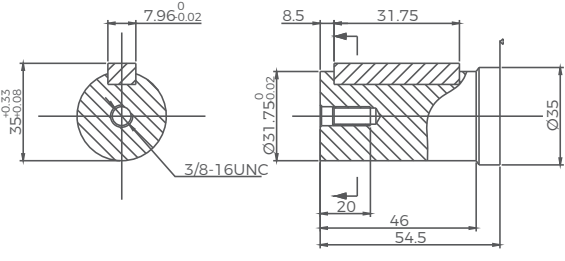
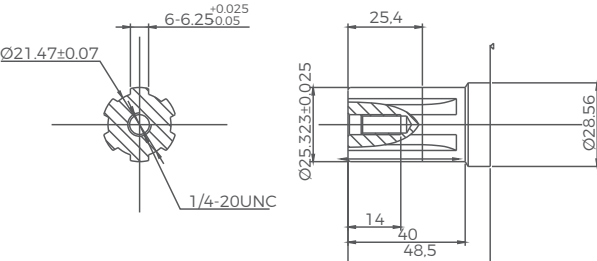
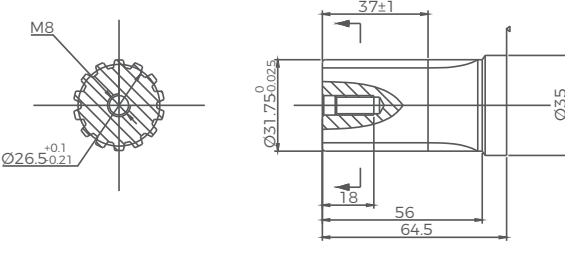
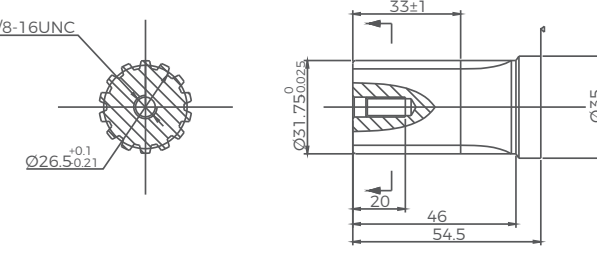
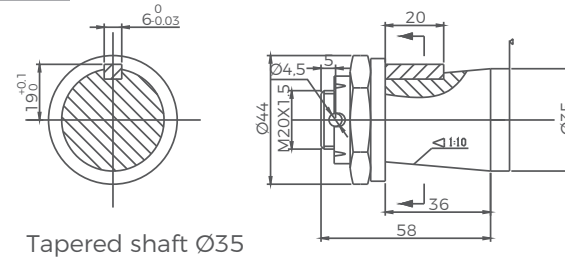
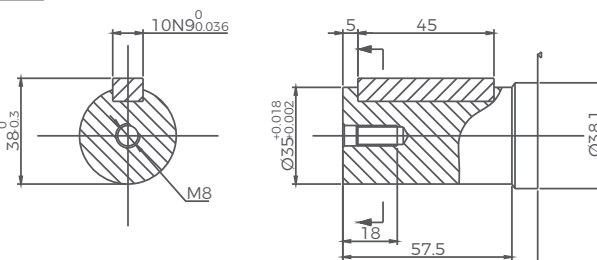
<p>S4</p>  <p>Straight shaft Ø32 Parallel key 10 x 8 x 45</p>	<p>SF</p>  <p>Straight shaft Ø35 Parallel key 10 x 8 x 45</p>
<p>SC</p>  <p>Straight shaft Ø31.75 Parallel key 7.96 x 7.96 x 31.75</p>	<p>R4</p>  <p>Splined shaft SAE 6B</p>
<p>R3</p>  <p>Splined shaft 14-DP 12/24</p>	<p>R6</p>  <p>Splined shaft 14-DP 12/24</p>
<p>T4</p>  <p>Tapered shaft Ø35 Parallel key B6 x 6 x 20 Tightening torque: 200 ± 10Nm</p>	<p>SH</p>  <p>Straight shaft Ø35 Parallel key 10 x 8 x 45</p>

GH Series Hydraulic Motors

Permissible shaft seal pressure

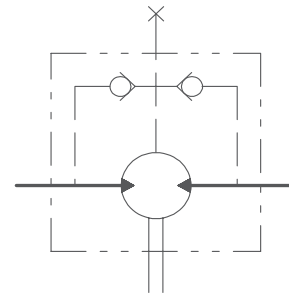
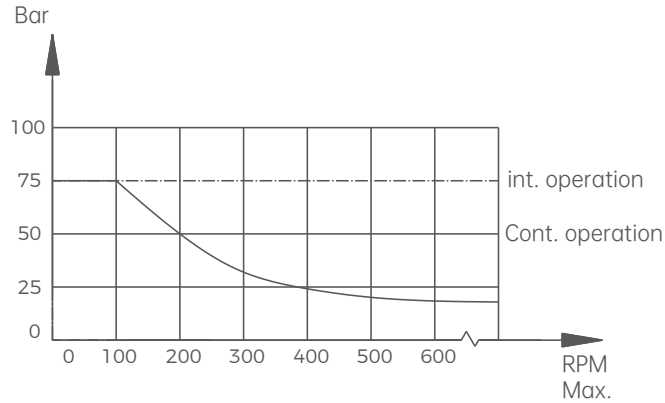

GH with standard shaft seal check valves and without use of drain connection: The pressure on the shaft seal never exceeds the pressure in the return line.

GH with standard shaft seal, check valves and with drain connection: The shaft seal pressure equals the pressure on the drain line.

Drain Port

In applications without drain line, output shaft seal exceeds a bit of the pressure in the return line. In applications using the drain line, the pressure of output shaft seal equals the pressure in drain line.

Standard direction of shaft rotation: Standard

When facing shaft end of motor, shaft to rotate:
Clockwise. When port A is pressurized.
Counter-clockwise when port B is pressurized.

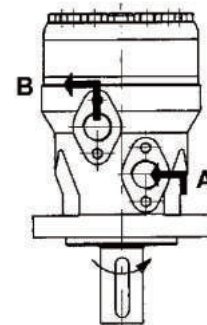

Axial and radial force

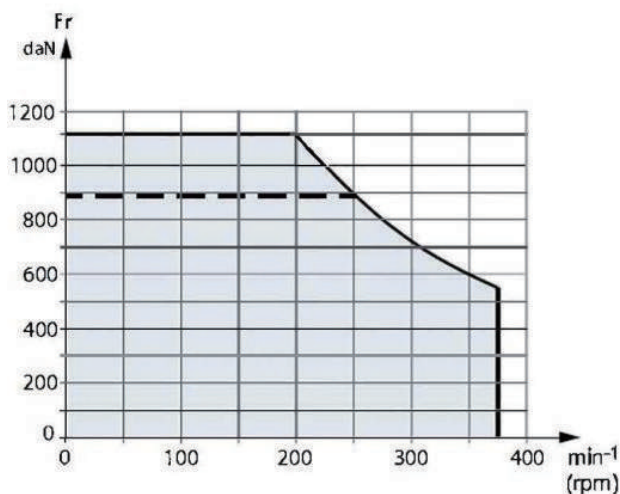

The drawing shows the permissible radial load when L = 30mm [1.18 in].

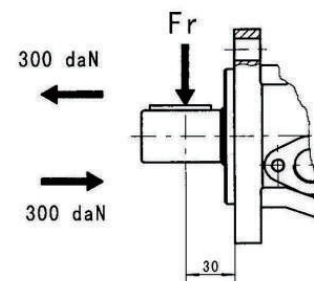

$$Fr = \frac{1100}{n} * \frac{25000}{103.5 + L} \text{ (daN)}$$

Fr = Radial Force (daN)

L = Distance (mm)

n = Speed (rpm)

GS Series Hydraulic Motors

Options

- Flange and wheel mount
- Bearingless motor
- Motor with brake
- Tachometer connection
- Speed sensing
- Side and rear ports
- Straight, splined and tapered shafts
- Shaft seal for high and low pressure
- Metric and BSPP ports
- Other special features

Applications

- Conveyors
- Road building machines
- Metal working machines
- Special vehicles
- Agricultural machines
- Food industries
- Mining machines







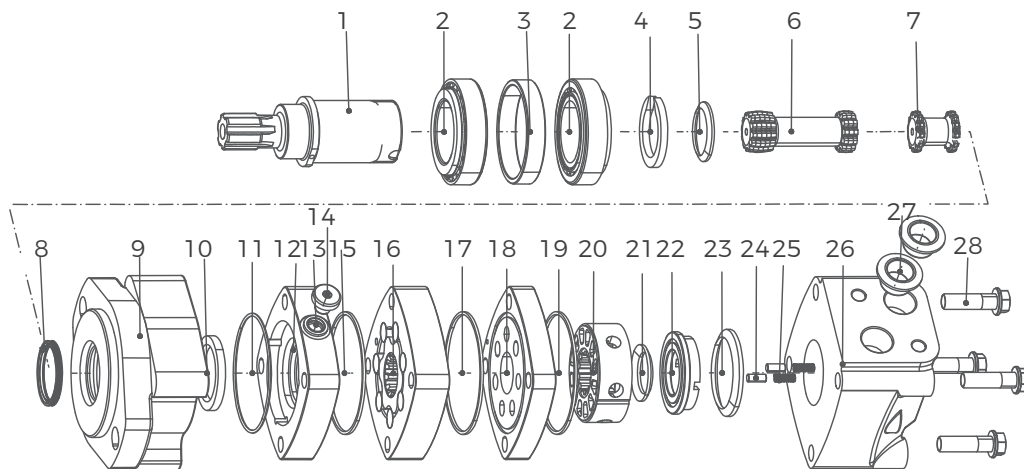

















General

Max. Displacement	cm ³ /rev [in ³ /rev]	564.9 [34.47]
Max. Speed	RPM	1000
Max. Torque	daNm [lb-in]	cont.: 85 [7520] int.: 99 [8760]
Max. Output	kW [HP]	23 [30.8]
Max. Pressure Drop	bar [PSI]	cont.: 210 [3050] int.: 275 [3990]
Max. Oil Flow	lpm [GPM]	90 [24]
Min. Speed	RPM	5
Pmissible Shaft Loads	daNm [lbs]	Pa=500 [1125]
Pressure fluid		Mineral based- HLP (DIN 51524) or HM (ISO 6743/4)
Temperature Range	°C [°F]	-40÷140 [-40÷284]
Optimal Viscosity range	mm ² /s [SUS]	20÷75 [98÷347]
Filtration		ISO code 20/16 (Min. recommended fluid filtration of 25 microns)



- | | | | |
|--------------------------|--------------------|----------------------------|------------------------|
| 1 Output shaft | 8 Anti-dust ring | 15 O-ring | 22 Flow pressure plate |
| 2 Tapered roller bearing | 9 Front cover | 16 Rotor and stator | 23 Special shape ring |
| 3 Bearing outer retainer | 10 Shaft seal | 17 Special shape ring | 24 Positioning pins |
| 4 Washers | 11 O-ring | 18 Balance plate | 25 Spring |
| 5 Special shape ring | 12 Connecting body | 19 Special shape ring | 26 Rear housing |
| 6 Transmission shaft | 13 Sealing gasket | 20 Flow distribution plate | 27 Oil port plug cap |
| 7 Coupling shaft | 14 Plug | 21 Special shape ring | 28 Screw |

Ordering Code

GS SERIES		DISP	FLANGE	SHAFT	PORTS	ROTATION	PAINT	FUNCTION	
CODE	TYPE	CODE	DISP	CODE	FLANGE	CODE	PORTS	CODE	PAINT
GS	Orbital motor	80	80.5cm ³ /rev [4.9in ³ /rev]	A7	2-Ø13.5 rhomb Ø106.4, pilot Ø82.5×6.3 	C9	G1/2, G1/4 manifold 2×M10	A	No paint
GSS	Bearingless motor	100	100cm ³ /rev [6.1in ³ /rev]	H3	4-Ø13.5 square Ø106.4, pilot Ø82.5×6.3 	M8	M22×1.5, M14×1.5 manifold 2×M10	B	Blue
		125	125.7cm ³ /rev [7.67in ³ /rev]	A9	6-Ø13.5 rhomb Ø106.4, pilot Ø82.5×2.6 	UB	7/8-14UNF O-ring, 7/16-20UNC manifold 2×3/8-16UNC	C	Black
		160	159.7cm ³ /rev [9.74in ³ /rev]	W1	4-Ø13.5 wheel Ø160, pilot Ø125×8 	UC	1/2-14 NPTF, 7/16-20UNF manifold 2×3/8-16UNC	S	Silver grey
		200	200cm ³ /rev [12.2in ³ /rev]	AA	2-Ø14.3 rhomb Ø146.05, pilot Ø101.6×9.4 				
		250	250cm ³ /rev [15.3in ³ /rev]	H1	4-Ø11.5 square Ø106.4, pilot Ø82.5×6.3 	CODE	SHAFT		
		315	314.9cm ³ /rev [19.2in ³ /rev]	B1	4-Ø11 circle Ø125, pilot Ø100×6 	C1	Cardan 12-DP 12/24 	A	Standard
		400	397cm ³ /rev [24.2in ³ /rev]	H2	4-Ø13.5 square Ø127, pilot Ø101.6×6.3 	S4	Ø32 parallel key 10×8×45 	F	Free running
		475	474.6cm ³ /rev [28.96in ³ /rev]			S8	Ø25.4 parallel key 6.35×6.35×25.4 	L	Low speed
		525	522.7cm ³ /rev [31.88in ³ /rev]			SG	Ø31.75 parallel key 7.96×7.96×31.75 	V	High temp.
		565	564.9cm ³ /rev [34.47in ³ /rev]			R2	Ø31.75 splined tooth 14-DP 12/24 	S	Low temp.
						R3	Long Ø31.75 splined tooth 14-DP 12/24 		
						R7	Ø34.85 splined tooth 6-34.85×28.14×8.64 		
						T4	Tapered Ø35 parallel key B6×6×20 		
						T5	Tapered Ø31.75 parallel key 7.96×7.96×31.75 		
						R8	Ø25.4 splined tooth SAE 6B 		
						R5	Ø22 splined tooth 13-DP16/32 		
						S1	Ø25 parallel key 8×7×32 		
						S6	Ø25.4 parallel key Ø25.4×6.35 		
						T2	Tapered Ø35 parallel key 7.96×7.96×25.4 		

Specifications

Type		GS80	GS100	GS125	GS160	GS200	GS250
Displacement, cm ³ /rev [in ³ /rev]		80,5[4.91]	100[6.1]	125,7[7.67]	159,7[9.74]	200[12.2]	250 [15.3]
Max. Speed	Cont	810	750	600	470	375	300
RPM	Int*	1000	900	720	560	450	360
Max. Torque	Cont	24[2120]	30,5[2700]	37,5[3320]	49[4340]	61[5400]	72[6370]
daNm [lb-in]	Int*	31[2740]	39[3450]	49[4340]	60[5310]	72[6370]	87[7700]
Max. Output	Cont	15,5[20.8]	18[24.1]	18[24.1]	16,5[22.1]	16,5[22.1]	14,5[19.4]
kW [HP]	Int*	19,5[26.2]	22,8[30.2]	22,5[30.2]	23[30.8]	22[29.52]	18[24.1]
Max. Pressure Drop	Cont	210[3050]	210[3050]	210[3050]	210[3050]	210[3050]	200[2900]
bar [PSI]	Int*	275[3990]	275[3990]	275[3990]	275[3990]	275[3990]	250[3630]
	Peak**	295[4280]	295[4280]	295[4280]	295[4280]	295[4280]	270[3920]
Max. Oil Flow	Cont	65[17]	75[20]	75[20]	75[20]	75[20]	75[20]
lpm [GPM]	Int*	80[21]	90[24]	90[24]	90[24]	90[24]	90[24]
Max. Inlet Pressure	Cont	230[3340]	230[3340]	230[3340]	230[3340]	230[3340]	230[3340]
bar [PSI]	Int*	295[4280]	295[4280]	295[4280]	295[4280]	295[4280]	295[4280]
	Peak**	300[4350]	300[4350]	300[4350]	300[4350]	300[4350]	300[4350]
Max. Return Pressure	Cont	140[2030]	140[2030]	140[2030]	140[2030]	140[2030]	140[2030]
with Drain Line	Int*	175[2540]	175[2540]	175[2540]	175[2540]	175[2540]	175[2540]
bar [PSI]	Peak**	210[3050]	210[3050]	210[3050]	210[3050]	210[3050]	210[3050]
Max. Starting Pressure with Unloaded Shaft, bar [PSI]		12[175]	10[145]	10[145]	8[115]	8[115]	8[115]
Min. Starting Torque	At max. press. drop Cont	18[1590]	23[2040]	29[2570]	37[3270]	47[4160]	56[4960]
daNm [lb-in]	At max. press. drop Int*	23,5[2080]	30[2660]	38[3360]	46[4070]	56[4960]	70[6200]
Min. Speed***, RPM		10	10	8	8	6	6
Weight, kg [lb] For	GS	9,9[21.8]	10,1[22.2]	10,4[22.9]	10,8[23.8]	11,2[24.7]	11,7[25.8]
rear port + 0,40 [.88]	GSS	7,9[17.4]	8,1[17.8]	8,4[18.5]	8,8[19.4]	9,2[20.2]	9,7[21.4]

Specifications

Type		GS315	GS400	GS475	GS525	GS565
Displacement, cm ³ /rev [in ³ /rev]		314,9[19.2]	397[24.2]	474,6[28.96]	522,7[31.88]	564,9[34.47]
Max. Speed	Cont.	240	190	160	145	130
RPM	Int.*	290	230	190	175	160
Max. Torque	Cont.	82,5[7300]	86,5 [7660]	85[7520]	85[7520]	85[7520]
daNm [lb-in]	Int.*	100[8850]	99[8760]	99[8760]	99[8760]	99[8760]
Max. Output	Cont.	15[20.1]	11[14.8]	8,4[11]	7,6[10.2]	6,9[9]
kW [HP]	Int.*	17[22.8]	12,5[16.8]	11,3[15]	10,4[13.9]	9,6[13]
Max. Pressure Drop	Cont.	200[2900]	160[2320]	130[1880]	115[1670]	105[1520]
bar [PSI]	Int.*	240[3480]	190[2760]	150[2180]	135[1960]	125[1810]
	Peak**	260[3770]	210[3050]	170[2470]	155[2250]	145[2100]
Max. Oil Flow	Cont.	75[20]	75[20]	75[20]	75[20]	75[20]
lpm [GPM]	Int.*	90[24]	90[24]	90[24]	90[24]	90[24]
Max. Inlet Pressure	Cont.	230[3340]	230[3340]	230[3340]	230[3340]	230[3340]
bar [PSI]	Int.*	295[4280]	295[4280]	295[4280]	295[4280]	295[4280]
	Peak**	300[4350]	300[4350]	300[4350]	300[4350]	300[4350]
Max. Return Pressure	Cont.	140[2030]	140[2030]	140[2030]	140[2030]	140[2030]
with Drain Line	Int.*	175[2540]	175[2540]	175[2540]	175[2540]	175[2540]
bar [PSI]	Peak**	210[3050]	210[3050]	210[3050]	210[3050]	210[3050]
Max. Starting Pressure		8[115]	8[115]	8[115]	8[115]	8[115]
with Unloaded Shaft, bar [PSI]						
Min. Starting Torque	At max. press. drop Cont.	71[6280]	71[6280]	71[6280]	71[6280]	71[6280]
daNm [lb-in]	At max. press. drop Int.*	85[7520]	84[7430]	84[7430]	84[7430]	84[7430]
Min. Speed***, RPM		5	5	5	5	5
Weight, kg [lb] For	GS	12,4[27.3]	13,1[29.3]	14,1[31]	14,6[32.2]	15[33.1]
rear port + 0,40 [.88]	GSS	10,4[22.9]	11,3[24.9]	12,1[26.7]	12,6[27.8]	13[28.6]

Function Diagrams

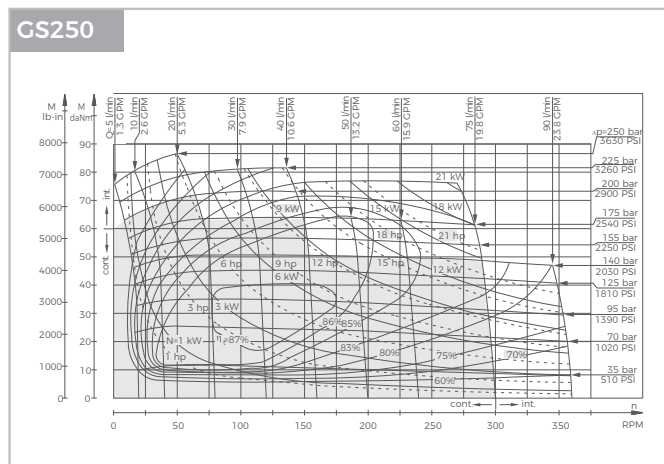
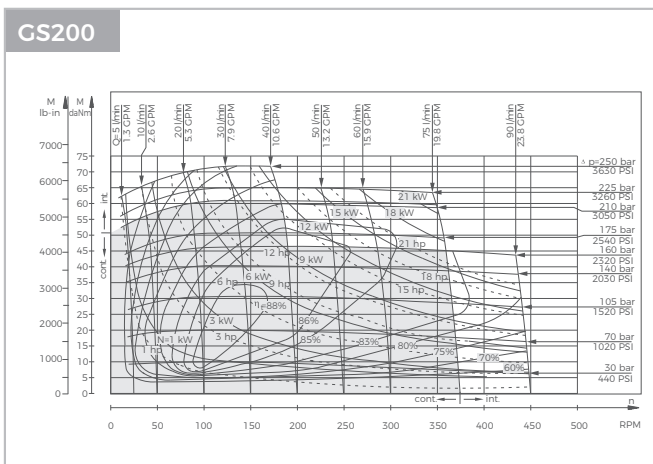
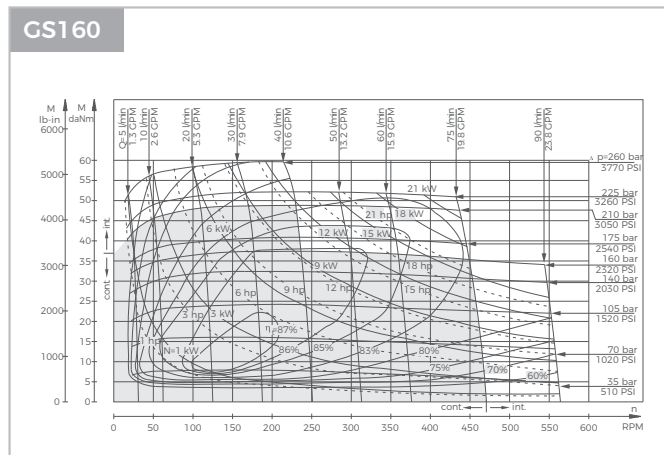
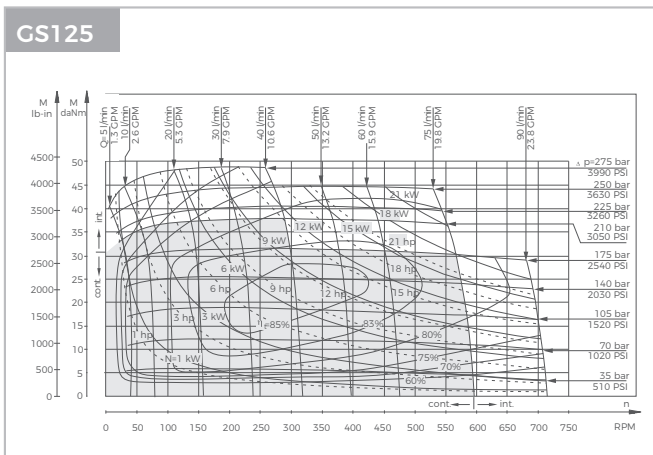
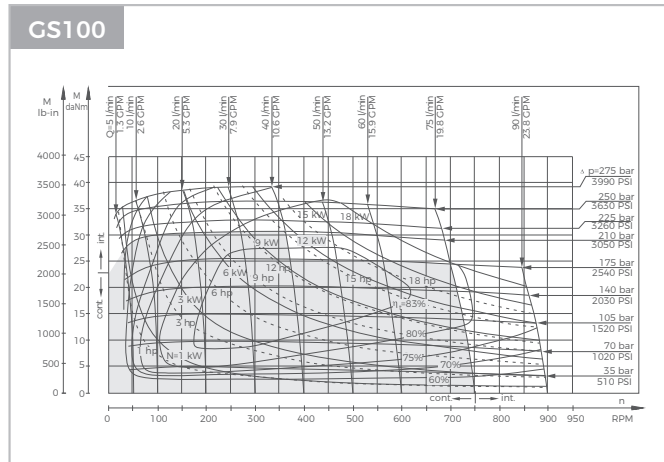
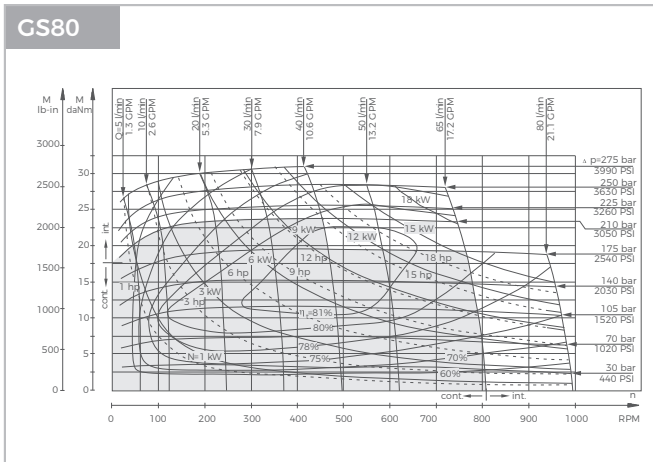

The function diagrams data is for average performance of randomly selected motors at backpressure. 5÷10 bar [72.5÷145 PSI] and oil with viscosity of 32 mm²/s [150 SUS] at 50°C [122°F].

Function Diagrams

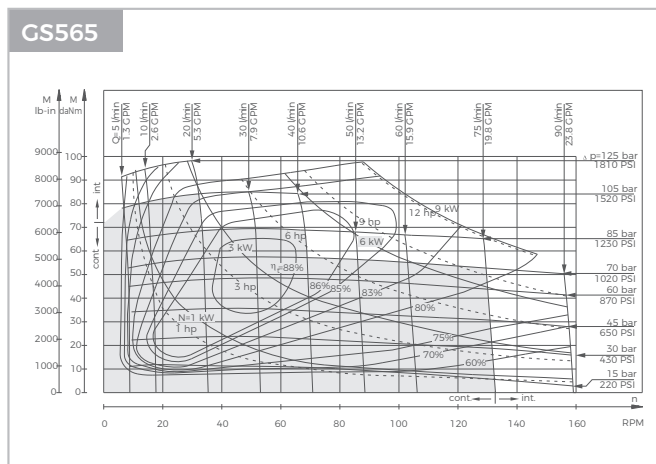
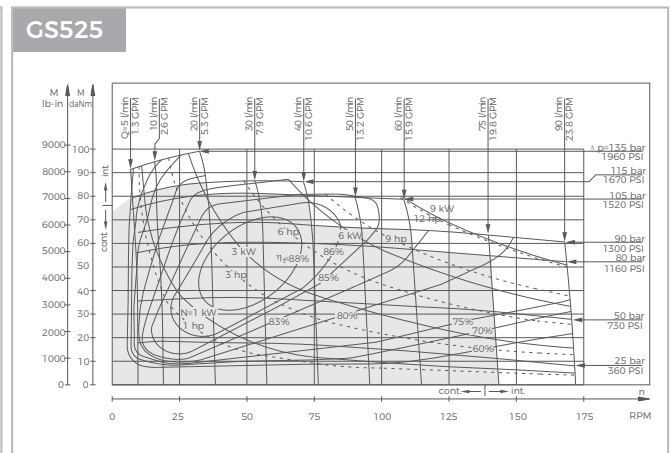
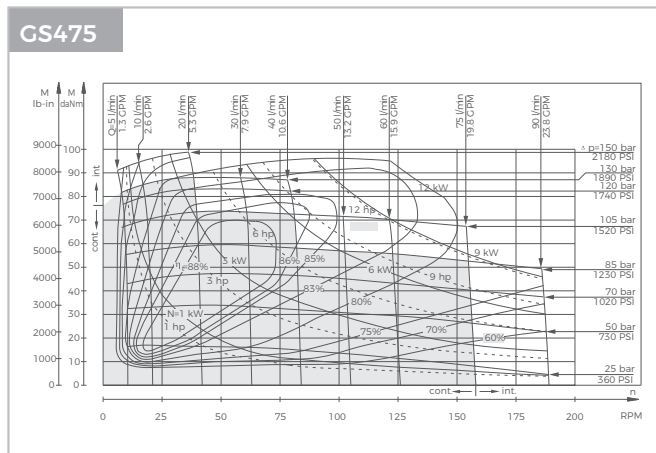
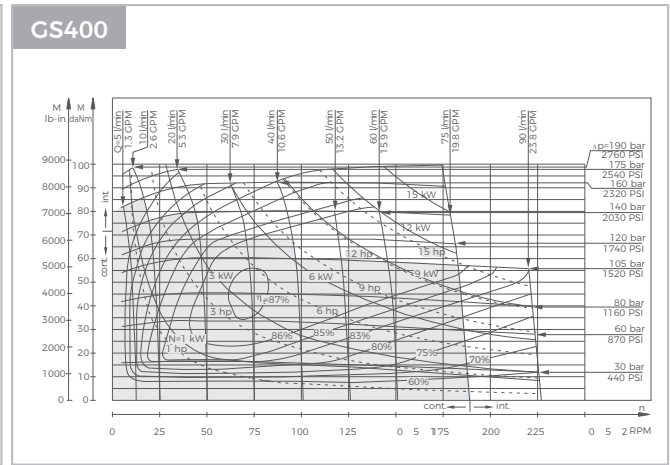
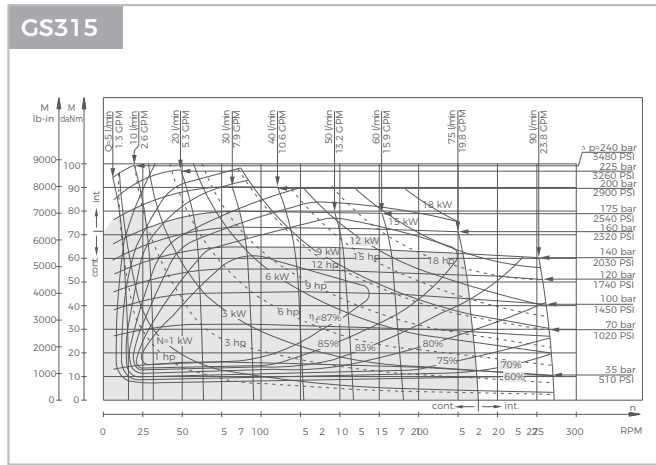

The function diagrams data is for average performance of randomly selected motors at backpressure. 5÷10 bar [72.5÷145 PSI] and oil with viscosity of 32 mm²/s [150 SUS] at 50°C [122°F].

GS Dimensions and Mountings

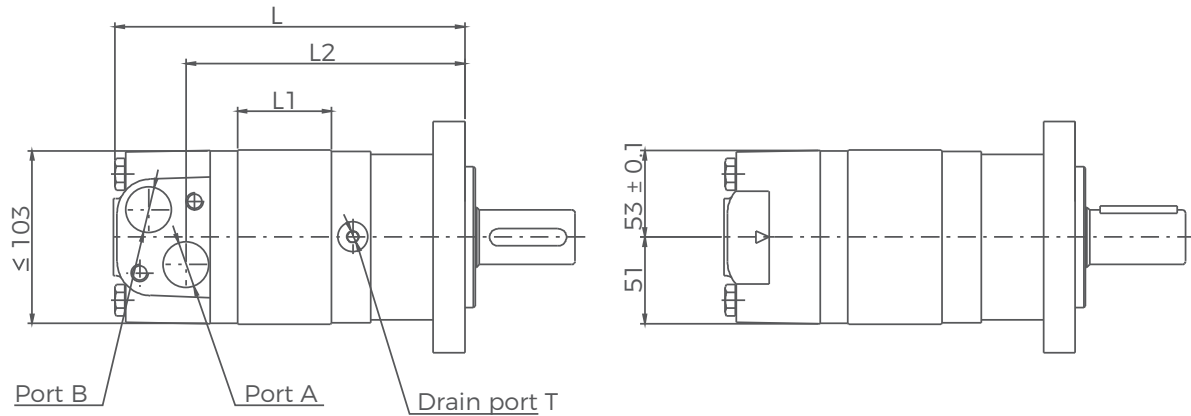

Model	L	L1	L2
GS80	170	16	126.5
GS100	174	20	130.5
GS125	179	25	135.5
GS160	181	27	137.5
GS200	188	34	144.5
GS250	196	42	152.5
GS315	208	54	164.5
GS400	223	69	179.5
GS475	237	83	193.5
GS525	229	75	185
GS565	235	80	191

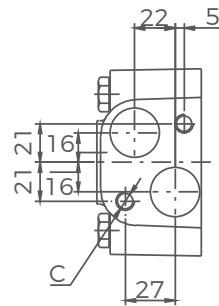

Mounting	G9 (depth)	M8 (depth)	UB (depth)	UC (depth)
P(A,B)	G1/2(15)	M22 x 1.5(15)	7/8-14 O-ring(17)	1/2-14 NPTF(15)
T	G1/4(12)	M14 x 1.5(12)	7/16-20 UNF(12)	7/16-20 UNF(12)
C	2-M10(13)	2-M10(13)	2-3/8-16 UNC(13)	2-3/8-16 UNC(13)

GS Flange Covers Dimensions

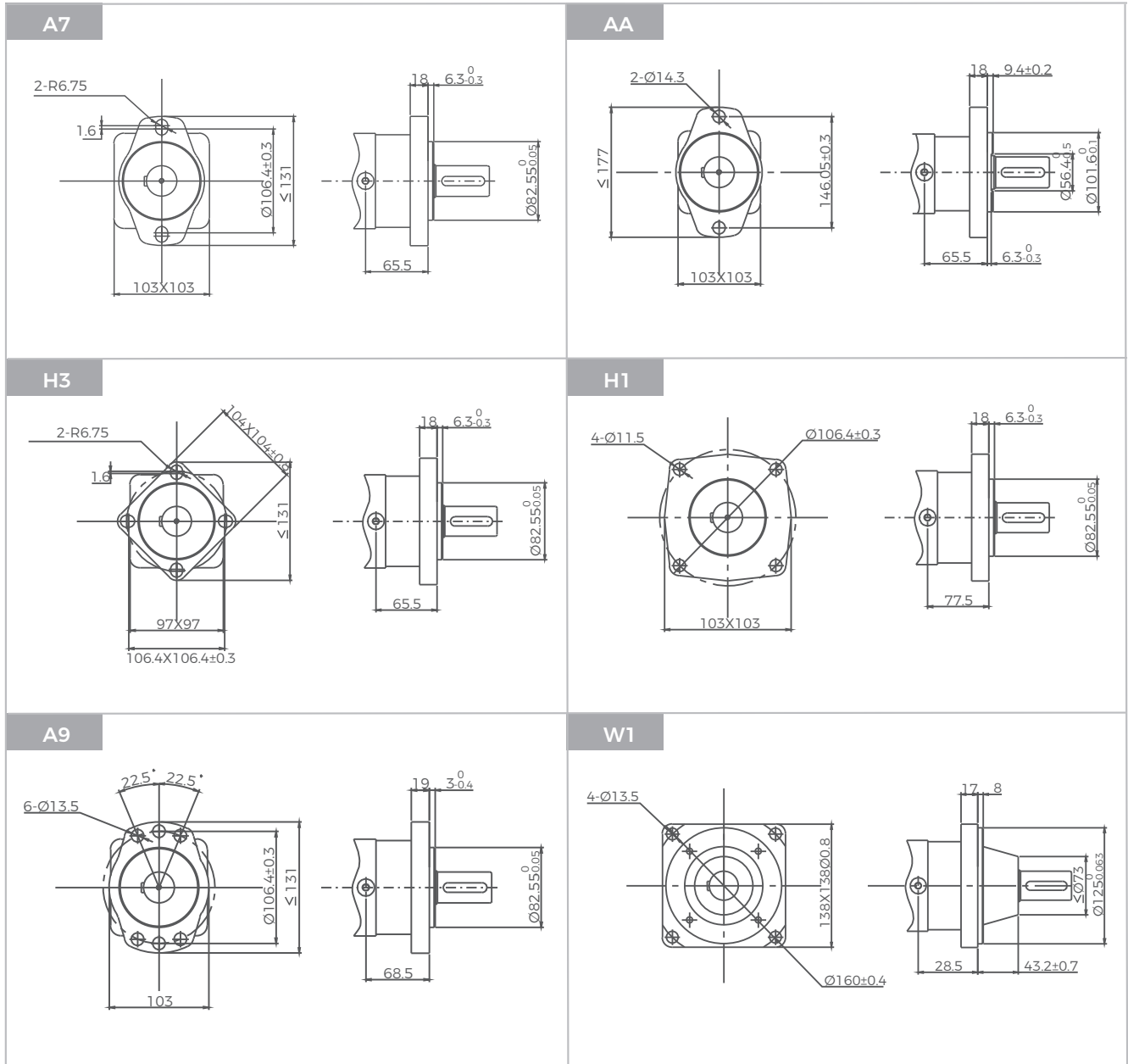

GSS Bearingless Motor Dimensions and Mounting

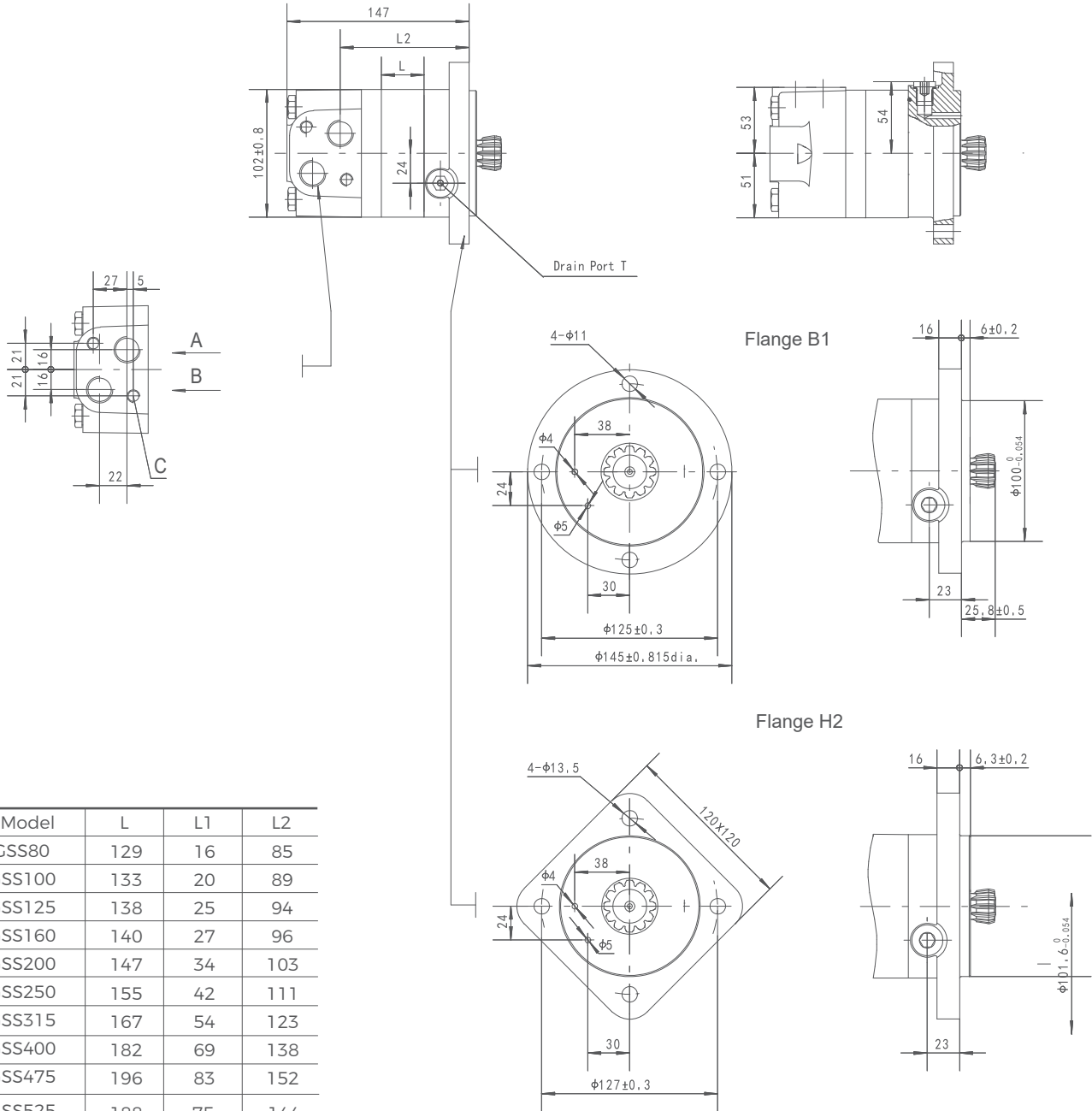

Model	L	L1	L2
GSS80	129	16	85
GSS100	133	20	89
GSS125	138	25	94
GSS160	140	27	96
GSS200	147	34	103
GSS250	155	42	111
GSS315	167	54	123
GSS400	182	69	138
GSS475	196	83	152
GSS525	188	75	144
GSS565	194	80	152

Mounting	C9 (depth)	M8 (depth)	UB (depth)	UC (depth)
P(A, B)	G1/2(15)	M22 x 1.5(15)	7/8-14 O-ring(17)	1/2-14 NPTF(15)
T	G1/4(12)	M14 x 1.5(12)	7/16-20 UNF(12)	7/16-20 UNF(12)
C	2-M10(13)	2-M10(13)	2-3/8-16 UNC(13)	2-3/8-16 UNC(13)

GS Shafts Dimensions

<p>S1</p> <p>Straight shaft $\varnothing 25$ Parallel key 8 x 7 x 32</p>	<p>S4</p> <p>Straight shaft $\varnothing 32$ Parallel key 10 x 8 x 45</p>
<p>S8</p> <p>Straight shaft $\varnothing 25.4$ Parallel key 6.35 x 6.35 x 25.4</p>	<p>SG</p> <p>Straight shaft $\varnothing 31.75$ Parallel key 7.96 x 7.96 x 31.75</p>
<p>R2</p> <p>Splined shaft 14-DP 12/24</p>	<p>R3</p> <p>Splined shaft 14-DP 12/24</p>
<p>S6</p> <p>Straight shaft $\varnothing 25.4$ Woodruff key $\varnothing 25.4$ x 6.35</p>	<p>R8</p> <p>Splined shaft SAE 6B</p>

CS Shafts Dimensions

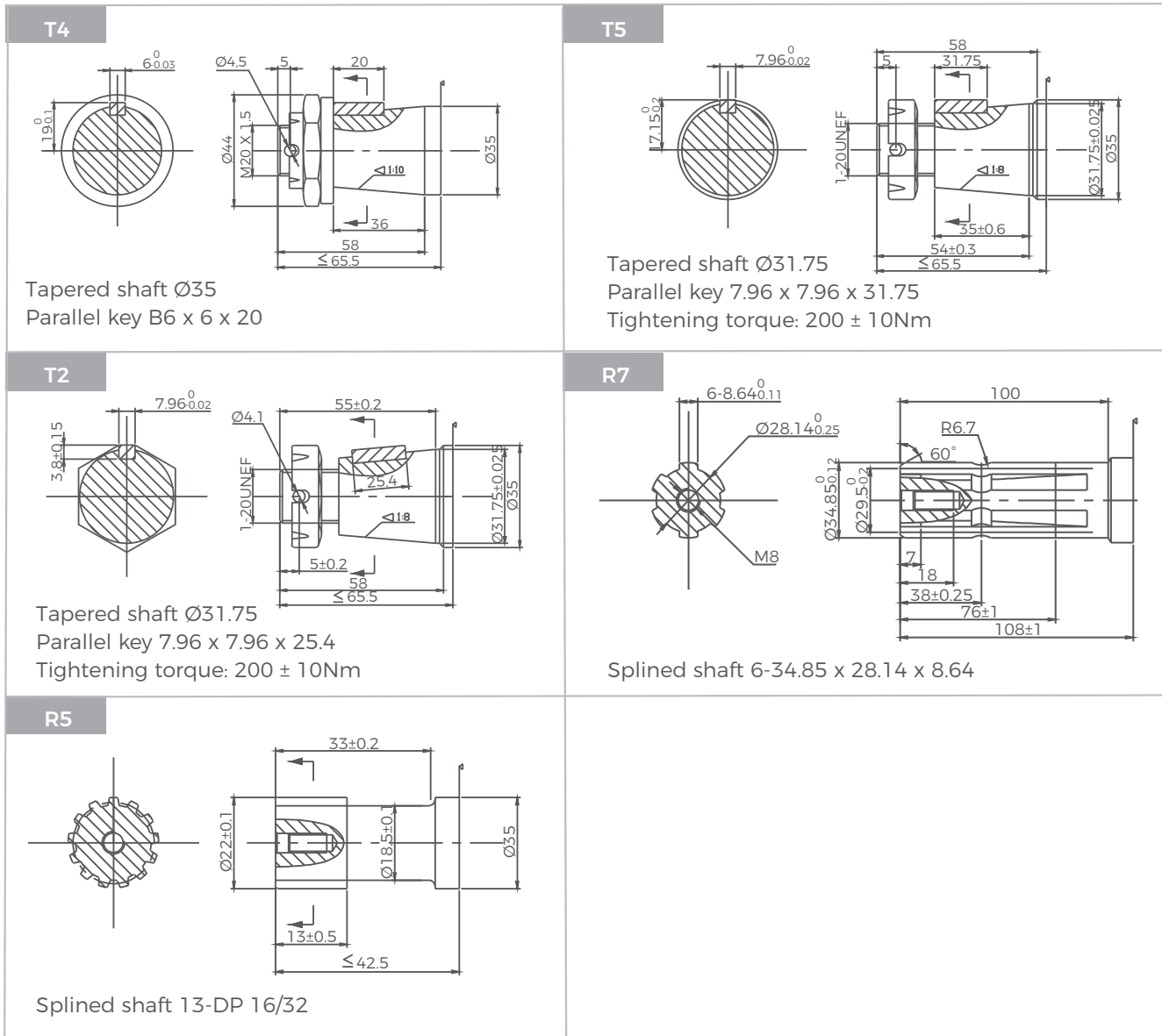

GS Series Hydraulic Motors

Permissible shaft seal pressure

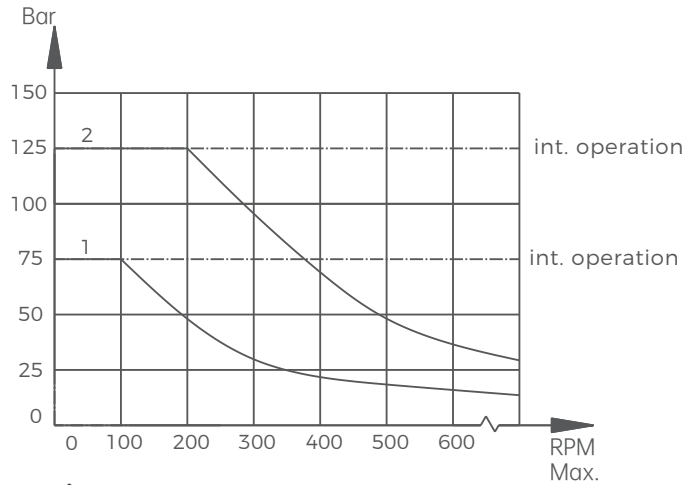

Drain Port

In applications without drain line, output shaft seal exceeds a bit of the pressure in the return line. In applications using the drain line, the pressure of output shaft seal equals the pressure in drain line.

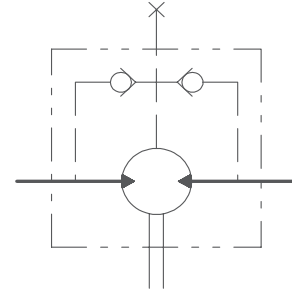

GS with standard shaft seal check valves and without use of drain connection: The pressure on the shaft seal never exceeds the pressure in the return line.

GS with standard shaft seal, check valves and with drain connection: The shaft seal pressure equals the pressure on the drain line.

Standard direction of shaft rotation: Standard

When facing shaft end of motor, shaft to rotate:
Clockwise. When port A is pressurized.
Counter-clockwise port B is pressurized.

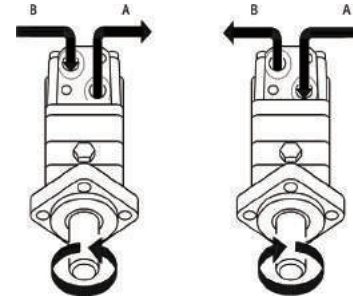

Axial and radial force

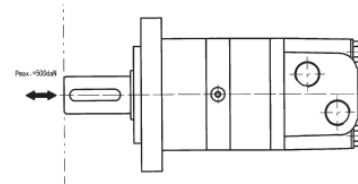
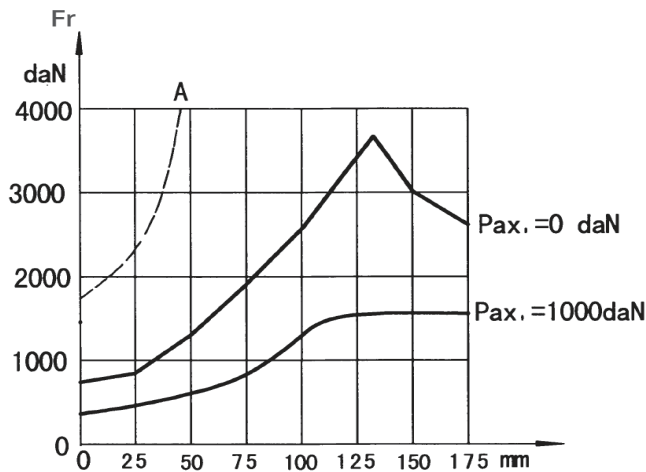

The output shaft runs in tapered bearings that permit high axial and radial forces, Curve "A" shows max radial shaft load, Any shaft loads exceeding the values quoted in the curve will involve a risk of breakage, The two other curves apply to a B10 bearing life of 3000 hours at 200 RPM.

GT Series Hydraulic Motors

Options

- Flange and wheel mount
- Bearingless motor
- Motor with brake
- Tachometer connection
- Speed sensing
- Side and rear ports
- Straight, splined and tapered shafts
- Metric and BSPP ports
- Other special features

Applications

- Metal working machines
- Agricultural machines
- Road building machines
- Mining machines
- Food industries
- Special vehicles
- Injection molding machines
- Conveyors







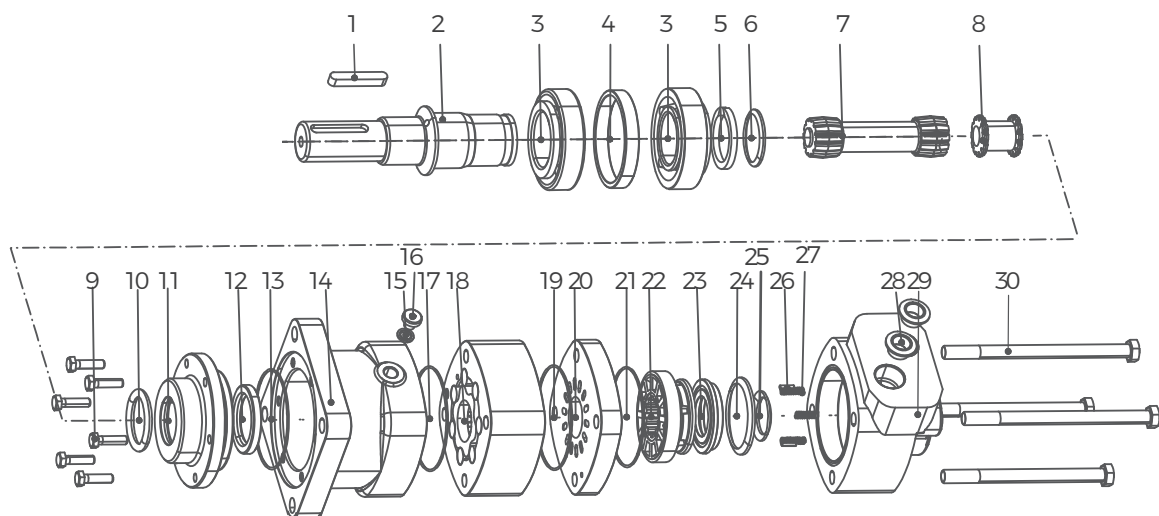









General

Max. Displacement	cm ³ /rev [in ³ /rev]	724.3 [44.2]
Max. Speed	RPM	775
Max. Torque	daNm [lb-in]	cont.: 130 [11500] int.: 148 [13100]
Max. Output	kW [HP]	40 [54]
Max. Pressure Drop	bar [PSI]	cont.: 200 [2900] int.: 240 [3480]
Max. Oil Flow	lpm [GPM]	150 [39.6]
Min. Speed	RPM	5
Pemissible Shaft Loads		Pa=1000 [2250]
Operating Fluid		Mineral based- HLP (DIN 51524) or HM (ISO 6743/4)
Temperature Range	°C [°F]	-40÷140 [-40÷284]
Optimal Viscosity range	mm ² /s [SUS]	20÷75 [98÷347]
Filtration		ISO code 20/16 (Min. recommended fluid filtration of 25 microns)



- | | | | | |
|--------------------------|----------------------|---------------------|----------------------------|-----------------------|
| 1 Parallel key | 7 Transmission shaft | 13 O-ring | 19 O-ring | 25 Small special ring |
| 2 Output shaft | 8 Coupling shaft | 14 Housing | 20 Balance plate | 26 Positioning pins |
| 3 Tapered roller bearing | 9 Hexagon screws | 15 Washer | 21 O-ring | 27 Spring |
| 4 Bearing outer retainer | 10 O-ring | 16 Plug | 22 Flow distribution plate | 28 Oil port plug cap |
| 5 Washers | 11 Front cover | 17 O-ring | 23 Flow pressure plate | 29 Rear housing |
| 6 Special shape ring | 12 Shaft seal | 18 Rotor and stator | 24 Large special ring | 30 Screw |

Ordering Code

GT SERIES		DISP		FLANGE		SHAFT		PORTS		ROTATION		PAINT		FUNCTION	
CODE	TYPE	CODE	DISP	CODE	FLANGE	CODE	SHAFT	CODE	PORTS	CODE	ROTATION	CODE	PAINT	CODE	FUNCTION
GT	Orbital motor	160	161.1cm ³ /rev [9.83in ³ /rev]	H6	4-Ø14square Ø160, pilot Ø125×9 	C2	Cardan 16-DP 12/24 	G3	G3/4, G1/4 manifold 4×M10	A	Standard	A	No Paint	A	Standard
GTS	Bearingless motor	200	201.4cm ³ /rev [12.29in ³ /rev]	H7	4-Ø14.5 square Ø162, pilot Ø127×9 	SK	Ø40 parallel key 12×8×70 	M5	M27×2, M14×1.5 manifold 4×M10	B	Blue	F	Free running	B	Blue
		250	251.8cm ³ /rev [15.36in ³ /rev]	W2	4-Ø18 wheel Ø200, pilot Ø160×7 	SL	Ø38.1 parallel key 9.53×9.53×57.15 	U4	1-1/16-12UN O-ring, 9/16-18UNF	C	Black	L	Low speed	C	Black
		315	326.3cm ³ /rev [19.90in ³ /rev]	B2	4-Ø14 circle Ø160, pilot Ø125×8 	R9	Ø38.1 splined tooth 17-DP 12/24 	U5	1-1/16-12UN O-ring, 7/16-20UNF	S	Silver grey	V	High Temp.	S	Silver grey
		400	410.9cm ³ /rev [25.06in ³ /rev]	H8	4-Ø14.5 square Ø162, pilot Ø127×10 	RA	Ø38.1 splined tooth 17-DP 12/24 	G4	G3/4, G1/4			S	Low Temp.		
		500	523.6cm ³ /rev [31.95in ³ /rev]			T6	Tapered 1:10 Ø45 parallel key B12×8×28 	M9	M27×2, M14×1.5						
		630	631.2cm ³ /rev [38.52in ³ /rev]			T7	Tapered 1:8 Ø45 parallel key 11.13×11.13×31.75 								
		725	724.3cm ³ /rev [44.2in ³ /rev]			R7	Ø34.85 splined tooth 6-34.85×28.14×8.64 								
						SM	Ø31.75 parallel key 7.96×7.96×40 								
						R3	Ø31.75 splined tooth 14-DP 12/24 								

Specifications

Type		GT160	GT200	GT250	GT315
Displacement, cm ³ /rev [in ³ /rev]		161,1[9,83]	201,4[12,29]	251,8[15,36]	326,3[19,90]
Max. Speed,	Cont.	622	620	496	382
RPM	Int.*	775	752	601	461
Max. Torque	Cont.	47[4160]	59[5220]	73[6460]	95[8410]
daNm [lb-in]	Int.*	56[4960]	71[6285]	88[7790]	114[10090]
	Peak**	66[5840]	82[7260]	102[9030]	133[11770]
Max. Output	Cont.	26,5[36]	33,5[45]	33,5[45]	33,5[45]
kW [HP]	Int.*	32[43]	40[54]	40[54]	40[54]
Max. Pressure Drop	Cont.	200[2900]	200[2900]	200[2900]	200[2900]
bar [PSI]	Int.*	240[3480]	240[3480]	240[3480]	240[3480]
	Peak**	280[4050]	280[4050]	280[4050]	280[4050]
Max. Oil Flow	Cont.	100[26]	125[33]	125[33]	125[33]
lpm [GPM]	Int.*	125[33]	150[39,6]	150[39,6]	150[39,6]
Max. Inlet Pressure	Cont.	210[3050]	210[3050]	210[3050]	210[3050]
bar [PSI]	Int.*	250[3600]	250[3600]	250[3600]	250[3600]
	Peak**	300[4350]	300[4350]	300[4350]	300[4350]
Max. Return Pressure	Cont.	140[2030]	140[2030]	140[2030]	140[2000]
without Drain Line	Int.*	175[2540]	175[2540]	175[2540]	175[2500]
bar [PSI]	Peak**	210[3050]	210[3050]	210[3050]	210[3000]
Max. Starting Pressure with Unloaded Shaft, bar [PSI]		10[150]	10[150]	10[150]	10[150]
Min. Starting Torque daNm [lb-in]	At max. press. drop Cont.	34[3010]	43[3800]	53[4690]	74[6550]
	At max. press. drop Int.*	41[3630]	52[4600]	63[5580]	89[7880]
Min. Speed***, RPM		10	9	8	7
Weight, kg [lb]	GT	20[44,1]	21,5[47,4]	21[46,3]	22[48,5]
For Reare Ports +0,450 [,992]	GTS	15[33,1]	15,5[34,2]	16[35,3]	17[37,5]

Specifications

Type		GT400	GT500	GT630	GT725
Displacement, cm ³ /rev [in ³ /rev]		410,9[25.06]	523,6[31.95]	631,2[38.52]	724,3[44.2]
Max. Speed	Cont.	304	238	197	172
RPM	Int.*	368	289	234	209
Max. Torque	Cont.	108[9560]	122[10800]	130[11500]	127[11240]
daNm [lb-in]	Int.*	126[11150]	137[12125]	148[13100]	147[13010]
	Peak**	144[12745]	160[14160]	176[15580]	175[15490]
Max. Output	Cont.	30[40]	26,5[36]	24,3[33]	20,2[27]
kW [HP]	Int.*	35[47]	30[40]	27,5[37]	26,8[36]
Max. Pressure Drop	Cont.	180[2610]	160[2320]	140[2010]	120[1740]
bar [PSI]	Int.*	210[3050]	180[2610]	160[2320]	140[2010]
	Peak**	240[3480]	210[3050]	190[2760]	165[2395]
Max. Oil Flow	Cont.	125[33]	125[33]	125[33]	125[33]
lpm [GPM]	Int.*	150[39.6]	150[39.6]	150[39.6]	150[39.6]
Max. Inlet Pressure	Cont.	210[3050]	210[3050]	210[3050]	210[3050]
bar [PSI]	Int.*	250[3600]	250[3600]	250[3600]	250[3600]
	Peak**	300[4350]	300[4350]	300[2000]	300[4350]
Max. Return Pressure	Cont.	140[2000]	140[2000]	140[2500]	140[2000]
without Drain Line	Int.*	175[2500]	175[2500]	175[3000]	175[2500]
bar [PSI]	Peak**	210[3000]	210[3000]	210[3000]	210[3000]
Max. Starting Pressure with Unloaded Shaft, bar [PSI]	At max. press. drop Cont.	10[150]	10[150]	10[150]	10[150]
Min. Starting Torque daNm [lb-in]	At max. press. drop Int.*	84[7435]	95[8410]	95[8410]	95[8410]
Min. Speed***, RPM		97[8585]	106[9380]	110[9740]	115[10180]
Min. Speed***, RPM		6	5	5	5
Weight, kg [lb]	GT	23[50.7]	24[52.9]	23,5[51.8]	24,5[54.0]
For Reare Ports +0,450 [.992]	GTS	18[39.7]	19[41.9]	18,5[40.8]	19,5[43.0]

Function Diagrams

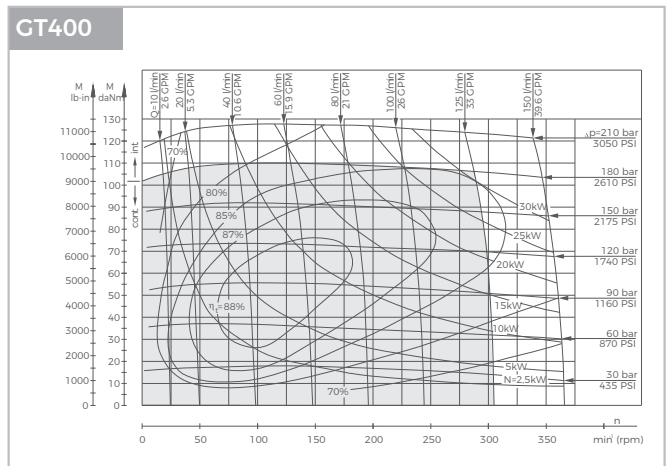
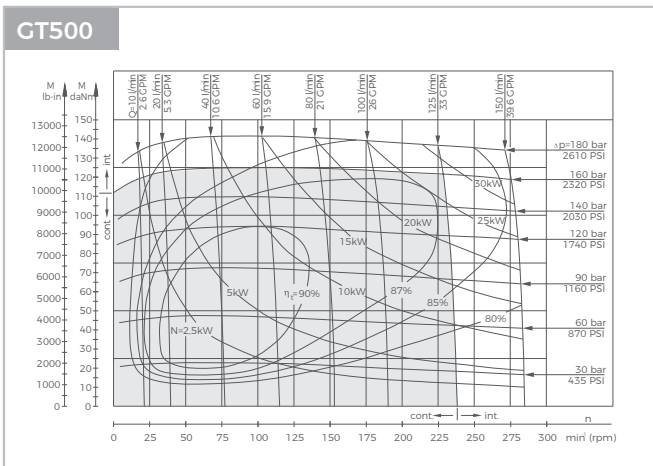
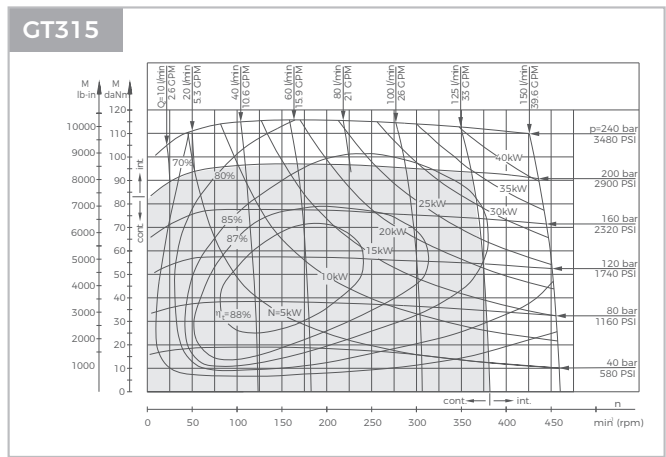
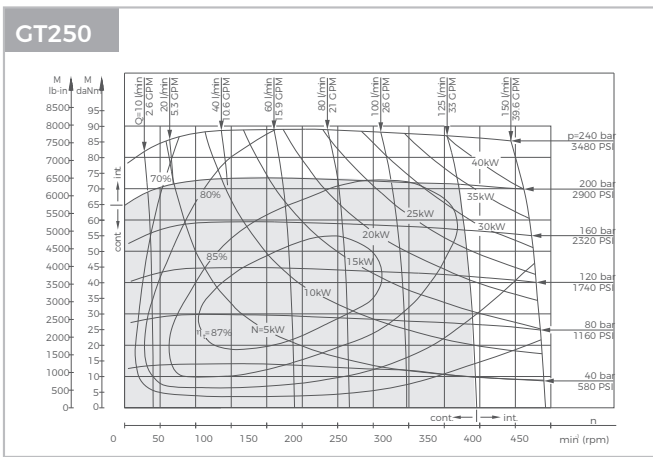
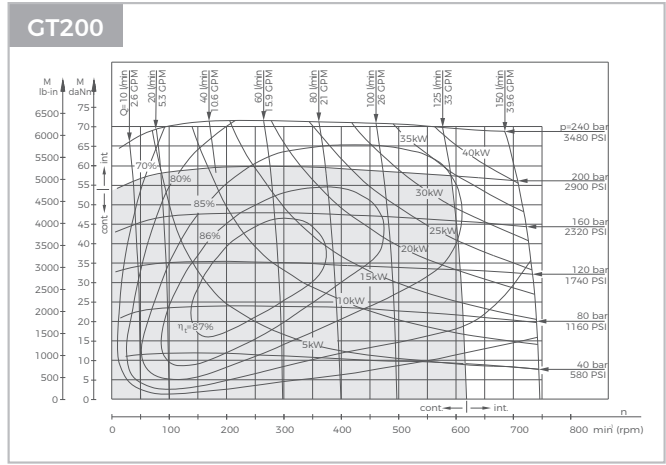
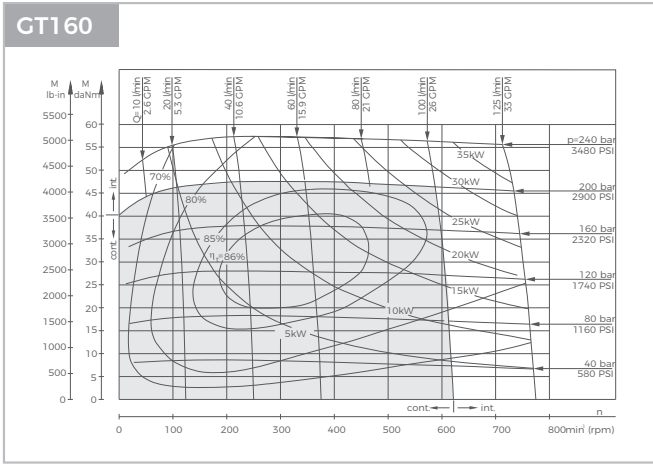

The function diagrams data is for average performance of randomly selected motors at backpressure. 5÷10 bar [72.5÷145 PSI] and oil with viscosity of 32 mm²/s [150 SUS] at 50°C [122°F].

Function Diagrams

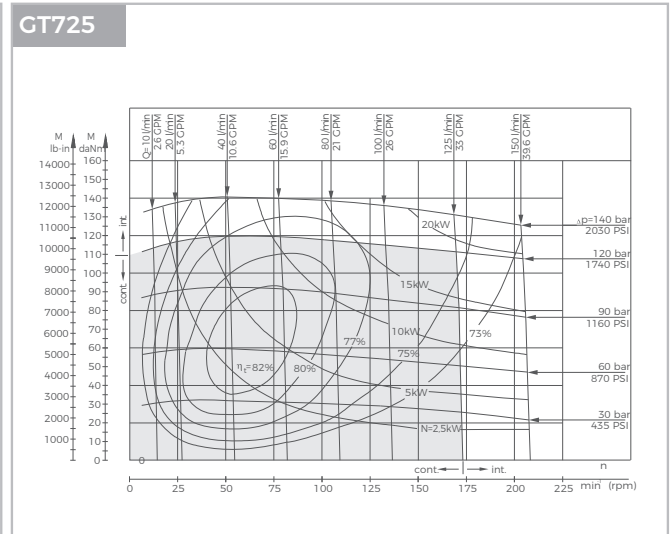
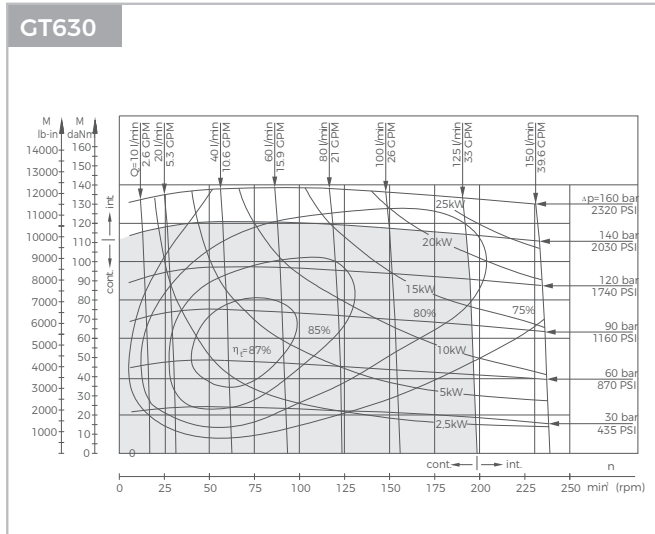

The function diagrams data is for average performance of randomly selected motors at backpressure. 5 ± 10 bar [72.5 \pm 145 PSI] and oil with viscosity of 32 mm²/s [150 SUS] at 50°C [122°F].

GT Dimensions and Mountings

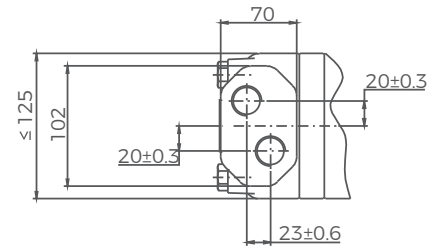
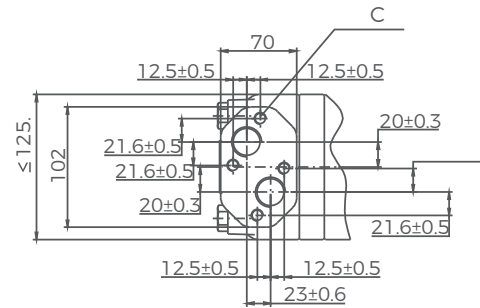
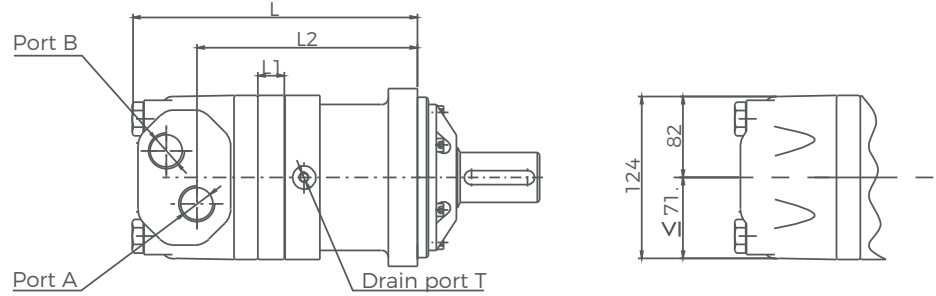

Model	L	L1	L2
GT160	193	17	142.5
GT200	197	21	146.5
GT250	204	14	152.5
GT315	210	20	158.5
GT400	217	27	165.5
GT500	225	35	173.5
GT630	237	47	185.5
GT725	248	58	196.5

Mounting	G3 (depth)	M5 (depth)	U4 (depth)	M9 (depth)	U5 (depth)
P(A, B)	G3/4(18)	M27 x 2(18)	1-1/16-12 UN(18)	M27 x 2(18)	1-1/16-12 UN(18)
T	G1/4(12)	M14 x 1.5(12)	9/16-18 UNF(12)	M14 x 1.5(12)	7/16-20 UNF(12)
C	4-M10(10)	4-M10(10)	—	—	—

GT Flange Covers Dimensions

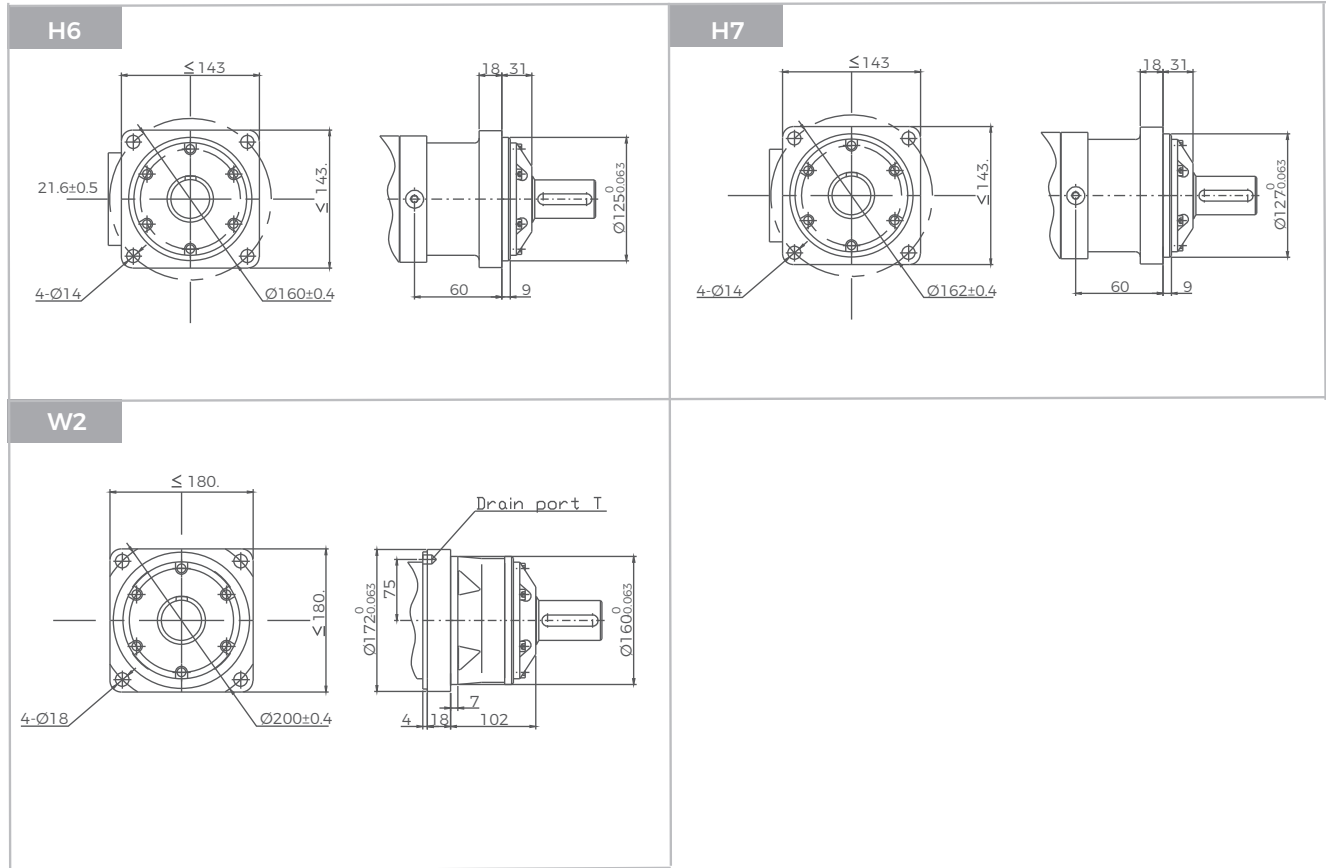

GTS Bearingless Motor Dimensions and Mounting

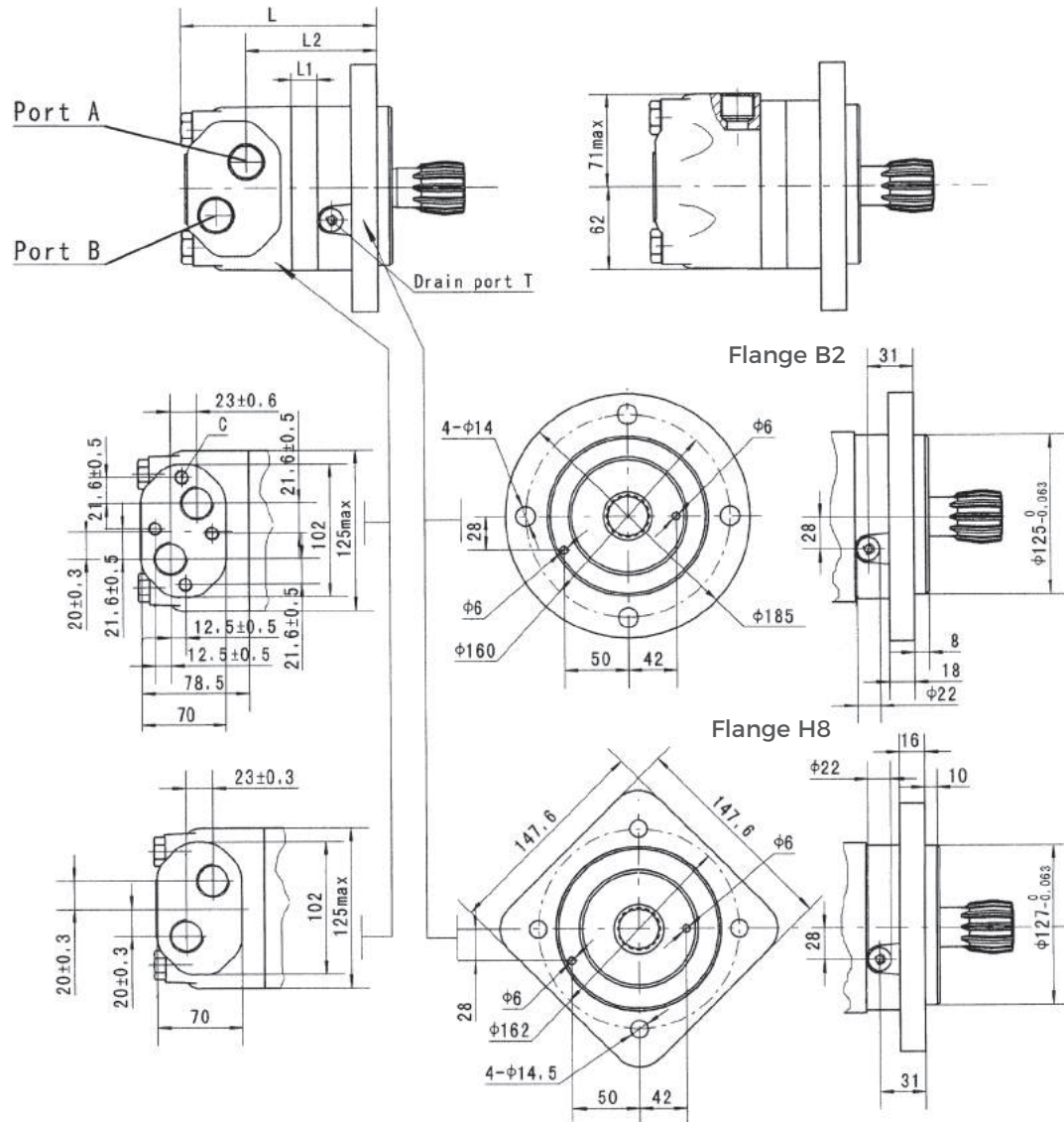

Model	L	L1	L2
GTS160	148	17	96.5
GTS200	152	21	100.5
GTS250	157	14	109
GTS315	163	20	115
GTS400	170	27	122
GTS500	178	35	130
GTS630	190	47	142
GTS725	201	58	153

Mounting	G3	M5	U4	M9	U5
	(depth)	(depth)	(depth)	(depth)	(depth)
P(A, B)	G3/4(18)	M27 x 2(18)	1-1/16-12 UN(18)	M27 x 2(18)	1-1/16-12 UN(18)
T	G1/4(12)	M14 x 1.5(12)	9/16-18 UNF(12)	M14 x 1.5(12)	7/16-20 UNF(12)
C	4-M10(10)	4-M10(10)	—	—	—

GT Shafts Dimensions

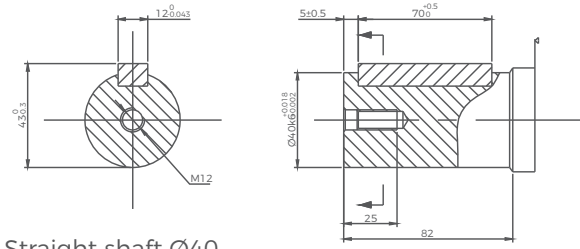
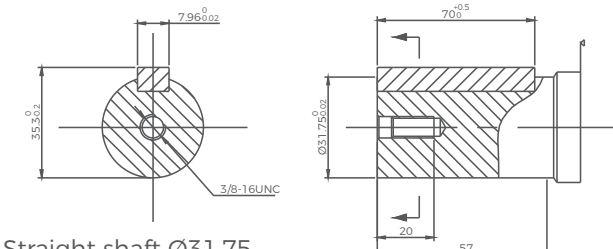
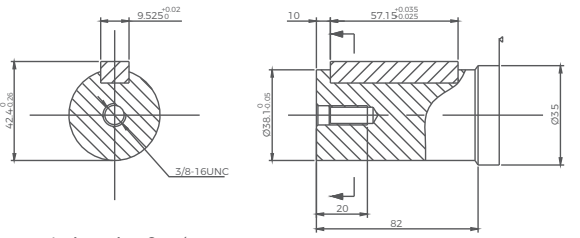
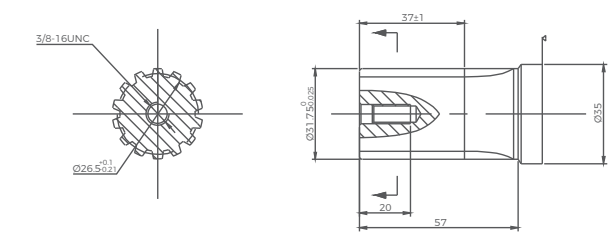
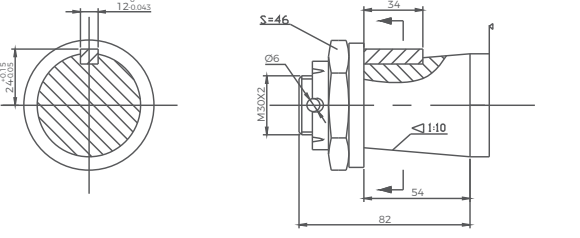
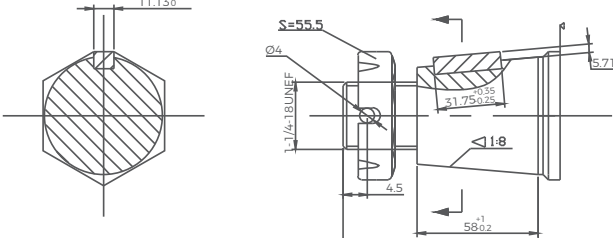
<p>SK</p>  <p>Straight shaft Ø40 Parallel key 12 x 8 x 70</p>	<p>SM</p>  <p>Straight shaft Ø31.75 Parallel key 7.96 x 7.96 x 40</p>
<p>SL</p>  <p>Straight shaft Ø38.1 Parallel key 9.525 x 9.525 x 57.15</p>	<p>R3</p>  <p>Splined shaft 14-DP 12/24</p>
<p>T6</p>  <p>Tapered shaft Ø45 Parallel key B12 x 8 x 28 Tightening torque: 500 ± 10 Nm</p>	<p>T7</p>  <p>Tapered shaft Ø45 Parallel key 11.13 x 11.13 x 31.75 Tightening torque: 500 ± 10 Nm</p>

GT Shafts Dimensions

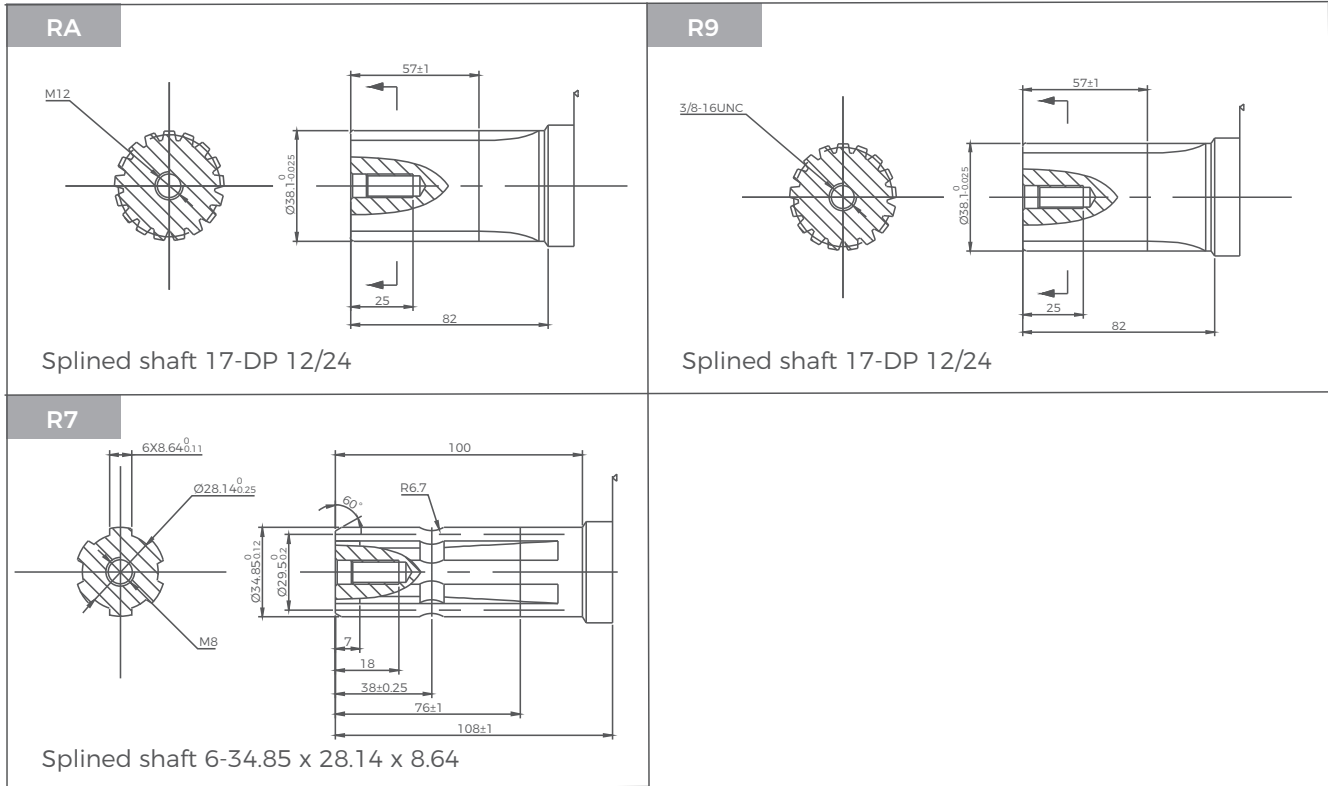

GT Series Hydraulic Motors

Permissible shaft seal pressure

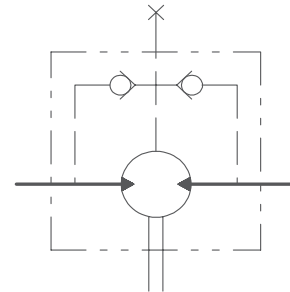
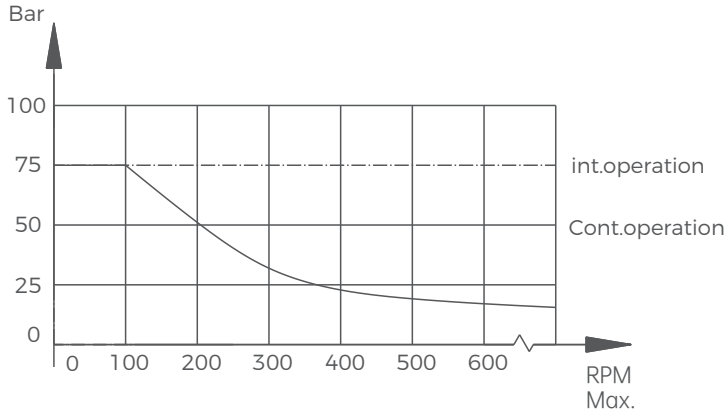

GT with standard shaft seal check valves and without use of drain connection: The pressure on the shaft seal never exceeds the pressure in the return line.

GT with standard shaft seal, check valves and with drain connection: The shaft seal pressure equals the pressure on the drain line.

Drain port

In applications without drain line, output shaft seal exceeds a bit of the pressure in the return line. In applications using the drain line, the pressure of output shaft seal equals the pressure in drain line.

Standard direction of shaft rotation: Standard

When facing shaft end of motor, shaft to rotate:

Clockwise. When port A is pressurized.

Counter-clockwise port B is pressurized.

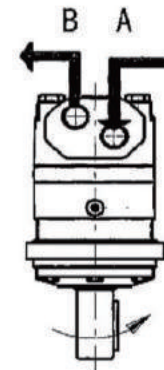

Axial and radial force

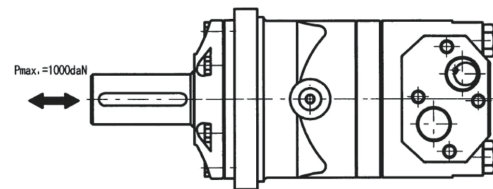
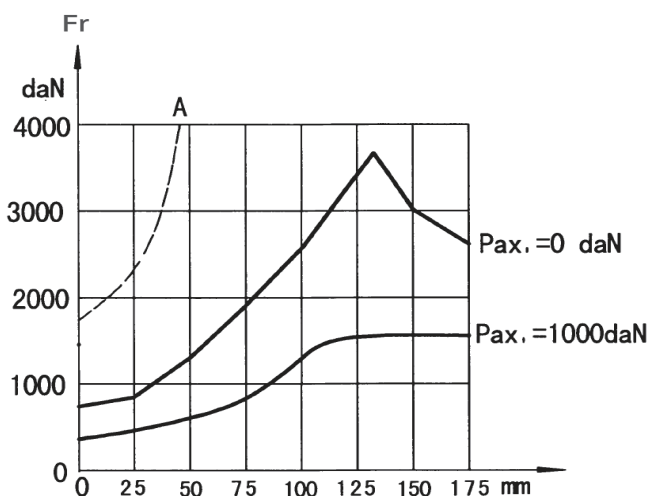

The output shaft runs in tapered bearings that permit high axial and radial forces, Curve "A" shows max radial shaft load, Any shaft loads exceeding the values quoted in the curve will involve a risk of breakage, The two other curves apply to a B10 bearing life of 3000 hours at 200 RPM.

GV Series Hydraulic Motors

Options

- Flange connection
- Bearingless motor
- Tachometer connection
- Side ports
- Straight, splined and tapered shafts
- Metric and BSPP ports
- Other special features

Applications

- Conveyors
- Metal working machines
- Agricultural machines
- Road building machines
- Mining machines
- Food industries
- Special vehicles
- Injection molding machines







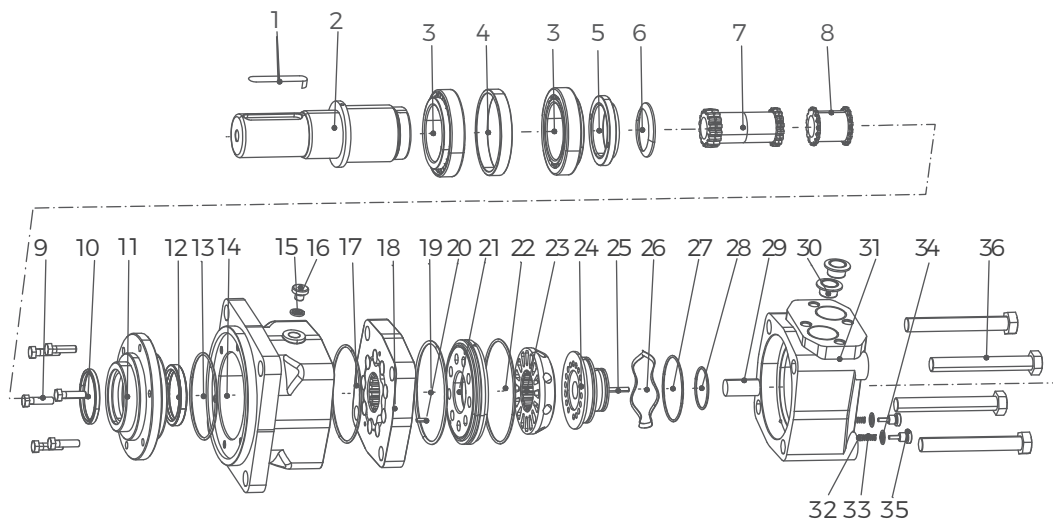



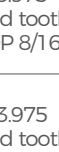

General

Max. Displacement	cm ³ /rev [in ³ /rev]	801,8 [48,91]
Max. Speed	RPM	630
Max. Torque	daNm [lb-in]	cont.: 188 [16650] int.: 211 [18650]
Max. Output	kW [HP]	64 [85,8]
Max. Pressure Drop	bar [PSI]	cont.: 200 [2900] int.: 240 [3480]
Max. Oil Flow	lpm [GPM]	240 [63,4]
Min. Speed	RPM	5
Permissible Shaft Loads	daNm [lbs]	Pa=1500 [3300]
Pressure fluid		Mineral based- HLP (DIN 51524) or HM (ISO 6743/4)
Temperature Range	°C [°F]	-40÷140 [-40÷284]
Optimal Viscosity range	mm ² /s [SUS]	20÷75 [98÷347]
Filtration		ISO code 20/16 (Min. recommended fluid filtration of 25 microns)



- | | | | | |
|----------------------|-------------------|---------------------|-------------------------------|----------------------|
| 1 Parallel Key | 8 Coupling shaft | 15 Washer | 22 O-ring | 29 Limit posts |
| 2 Output shaft | 9 Hexagon screws | 16 Plugs | 23 Flow distribution plate | 30 Oil port plug cap |
| 3 Roller bearing | 10 Anti-dust ring | 17 O-ring | 24 Distributor pressure plate | 31 Rear cover |
| 4 Bearing retainer | 11 Front cover | 18 Rotor and stator | 25 Positioning pins | 32 Steel ball |
| 5 Lock nut | 12 Shaft seal | 19 O-Ring | 26 Wave spring | 33 Spring |
| 6 Special shape ring | 13 O-ring | 20 Positioning pins | 27 O-ring | 34 Washer |
| 7 Transmission shaft | 14 Housing | 21 Balance plate | 28 O-ring | 35 Hexagon plugs |
| | | | | 36 Screw |

Ordering Code

CV SERIES		DISP		FLANGE		SHAFT		PORTS		ROTATION		PAINT		FUNCTION	
CODE	TYPE	CODE	DISP	CODE	FLANGE	CODE	SHAFT	CODE	PORTS	CODE	ROTATION	CODE	PAINT	CODE	FUNCTION
GV	Orbital motor	315	314.5cm ³ /rev [19.18in ³ /rev]	H9	4- Ø18 square Ø200, pilot Ø160×11 	C3	Cardan 16-DP 10/20 	G5	G1, G1/4 manifold 4×M12	A	Standard	A	No paint	A	Standard
CVS	Bearingless motor	400	400.9cm ³ /rev [24.45in ³ /rev]	W3	4- Ø18 wheel Ø224, pilot Ø180×10 	SN	Ø50 parallel key 14×9×70 	M6	M33×2, M14×1.5 manifold 4×M12	B	High temp.	B	Blue	V	High temp.
		500	499.6cm ³ /rev [30.48in ³ /rev]	B3	4- Ø14 square Ø180, pilot Ø140×8 	RB	Ø53.975 splined tooth 16-DP 8/16 	U6	1-5/16-12UNF O-ring manifold 9/16-18UNF	C	Low temp.	C	Black	S	Low temp.
		630	629.1cm ³ /rev [38.38in ³ /rev]	S	4- Ø14 circle Ø180, pilot Ø140×8 	RC	Ø53.975 splined tooth 16-DP 8/16 	G6	G1, G1/4	S	Silver grey	S	Silver grey		
		800	801.8cm ³ /rev [48.91in ³ /rev]			SP	Ø57.15 parallel key 12.7×12.7×57.16 	M7	M33×2, M14×1.5						
						T8	Tapered Ø57.15 parallel key 16×10×32 	U7	1-5/16-12UNF O-ring 7/16-20UNF						
						T9	Tapered Ø60 parallel key 14.308×14.308×50.8 								

Specifications

Type		GV315	GV400	GV500	GV630	GV800
Displacement, cm ³ /rev [in ³ /rev]		314,5[19.18]	400,9[24.45]	499,6[30.48]	629,1[38.38]	801,8[48.91]
Max. Speed	Cont.	510	500	400	320	250
RPM	Int.*	630	600	480	380	300
Max. Torque	Cont.	92[8150]	118[10450]	146[12950]	166[14700]	188[16650]
daNm [lb-in]	Int.*	111[9800]	141[12500]	176[15550]	194[17150]	211[18650]
	Peak**	129[11400]	164[14500]	205[18150]	221[19550]	247[21850]
Max. Output	Cont.	42,5[57]	53,5[71.7]	53,5[71.7]	48[64.4]	42,5[57]
kW [HP]	Int.*	51[68.4]	64[85.8]	64[85.8]	56[75]	48[64.4]
Max. Pressure Drop	Cont.	200[2900]	200[2900]	200[2900]	180[2610]	160[2320]
bar [PSI]	Int.*	240[3480]	240[3480]	240[3480]	210[3050]	180[2610]
	Peak**	280[4060]	280[4060]	280[4060]	240 [3480]	210[3050]
Max. Oil Flow	Cont.	160[42.3]	200[52.8]	200[52.8]	200[52.8]	200[52.8]
lpm [GPM]	Int.*	200[52.8]	240[63.4]	240[63.4]	240[63.4]	240[63.4]
Max. Inlet Pressure	Cont.	210[3050]	210[3050]	210[3050]	210[3050]	210[3050]
bar [PSI]	Int.*	250[3620]	250[3620]	250[3620]	250[3620]	250[3620]
	Peak**	300[4350]	300[4350]	300[4350]	300[4350]	300[4350]
Max. Return Pressure	Cont.	140[2040]	140[2040]	140[2040]	140[2040]	140[2040]
without Drain Line	Int.*	175[2540]	175[2540]	175[2540]	175[2540]	175[2540]
bar [PSI]	Peak**	210[3050]	210[3050]	210[3050]	210[3050]	210[3050]
Max. Starting Pressure with Unloaded Shaft, bar [PSI]		8[120]	8[120]	8[120]	8[120]	8[120]
Min. Starting Torque daNm [lb-in]	At max. press. drop Cont.	71[6300]	91[8100]	113[10000]	133[11800]	151[13400]
	At max. press. drop Int.*	85[7500]	109[9600]	136[12000]	155[13700]	170[15000]
		10	9	8	6	5
Min. Speed***, RPM	GV	31,8[70.1]	32,6[71.9]	33,5[73.8]	34,9[76.9]	36,5[80.5]
Weight, kg [lb]	GV5	22,7[50]	23,5[51.8]	24,4[53.8]	25,6[56.4]	27,7[61.1]

Function Diagrams

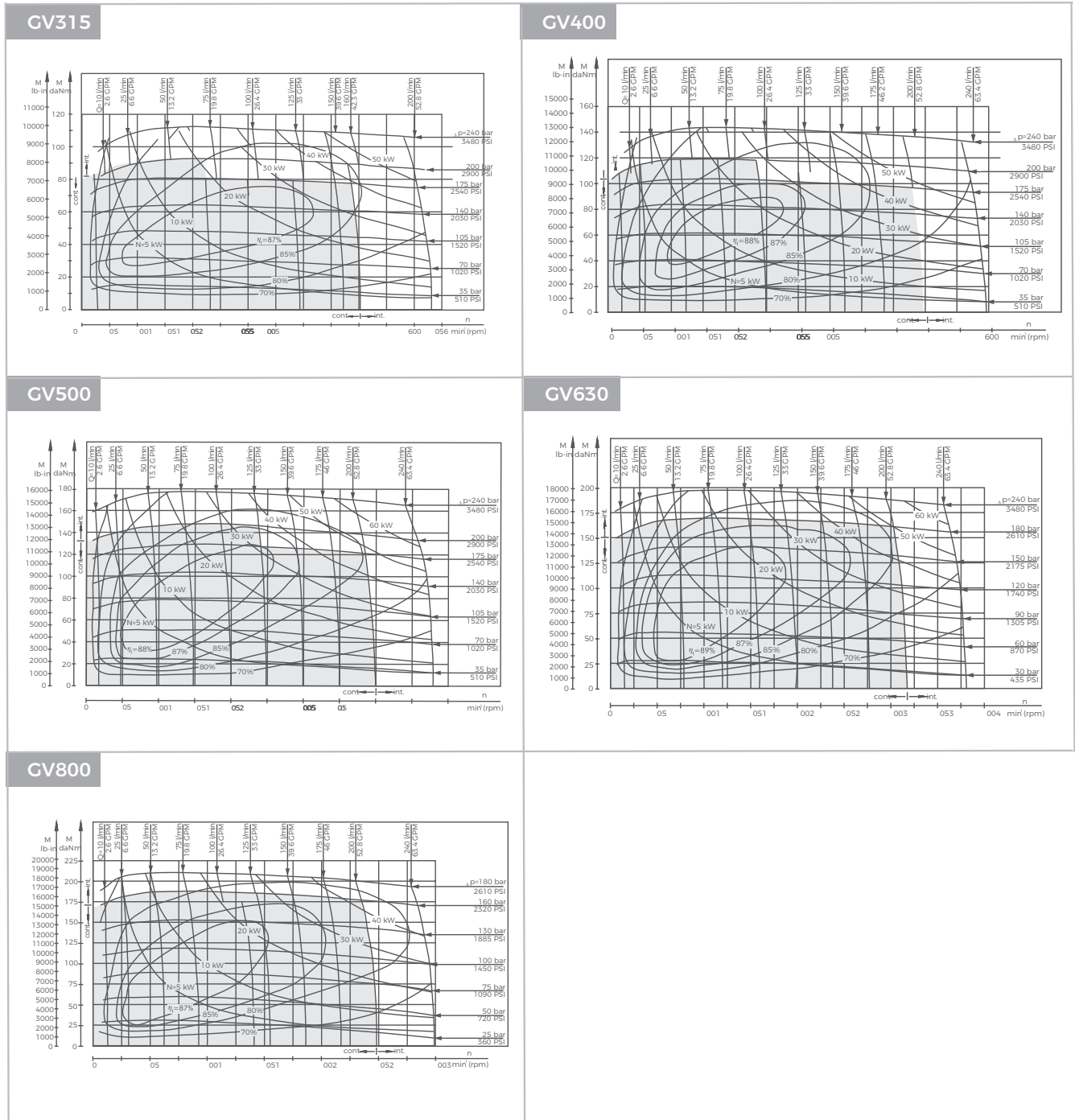

The function diagrams data is for average performance of randomly selected motors at backpressure. 5±10 bar [72.5÷145 PSI] and oil with viscosity of 32 mm²/s [150 SUS] at 50°C [122°F].

GV Dimensions and Mountings

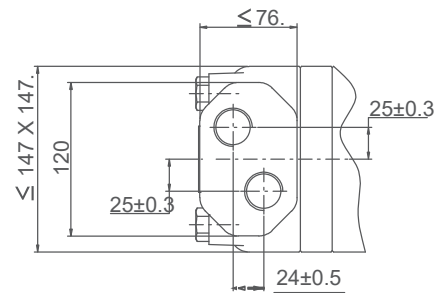
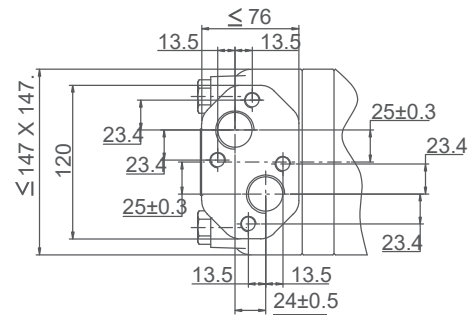
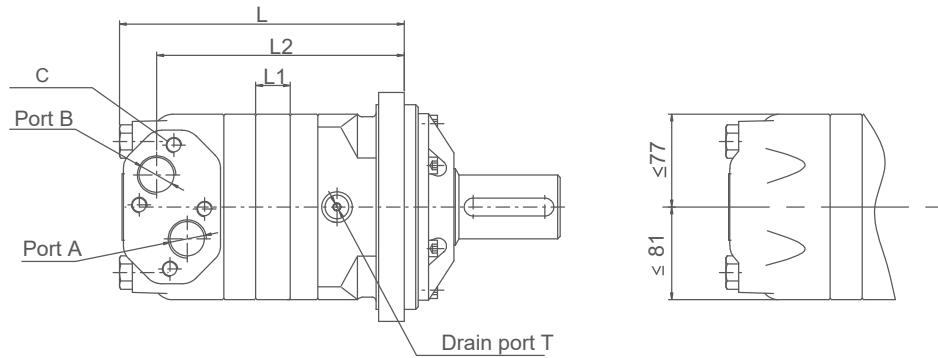

Model	L	L1	L2
GV315	217	20	161.5
GV400	224	27	168.5
GV500	232	35	176.5
GV630	244	47	188.5
GV800	255	58	199.5

Mounting	G5 (depth)	M6 (depth)	U6 (depth)	G6 (depth)	M7 (depth)	U7 (depth)
P(A, B)	G1(18)	M33 X 12(18)	1-5/16-12UN(18)	G1(18)	M33 X 2(18)	1-5/16-12UN(18)
T	G1/4(12)	M14 X 1.5(12)	9/16-18UNF(12)	G1/4(12)	M14 X 1.5 (12)	7/16-20UNF(12)
C	4-M12(12)	4-M12(12)				

GV Flange Covers Dimensions

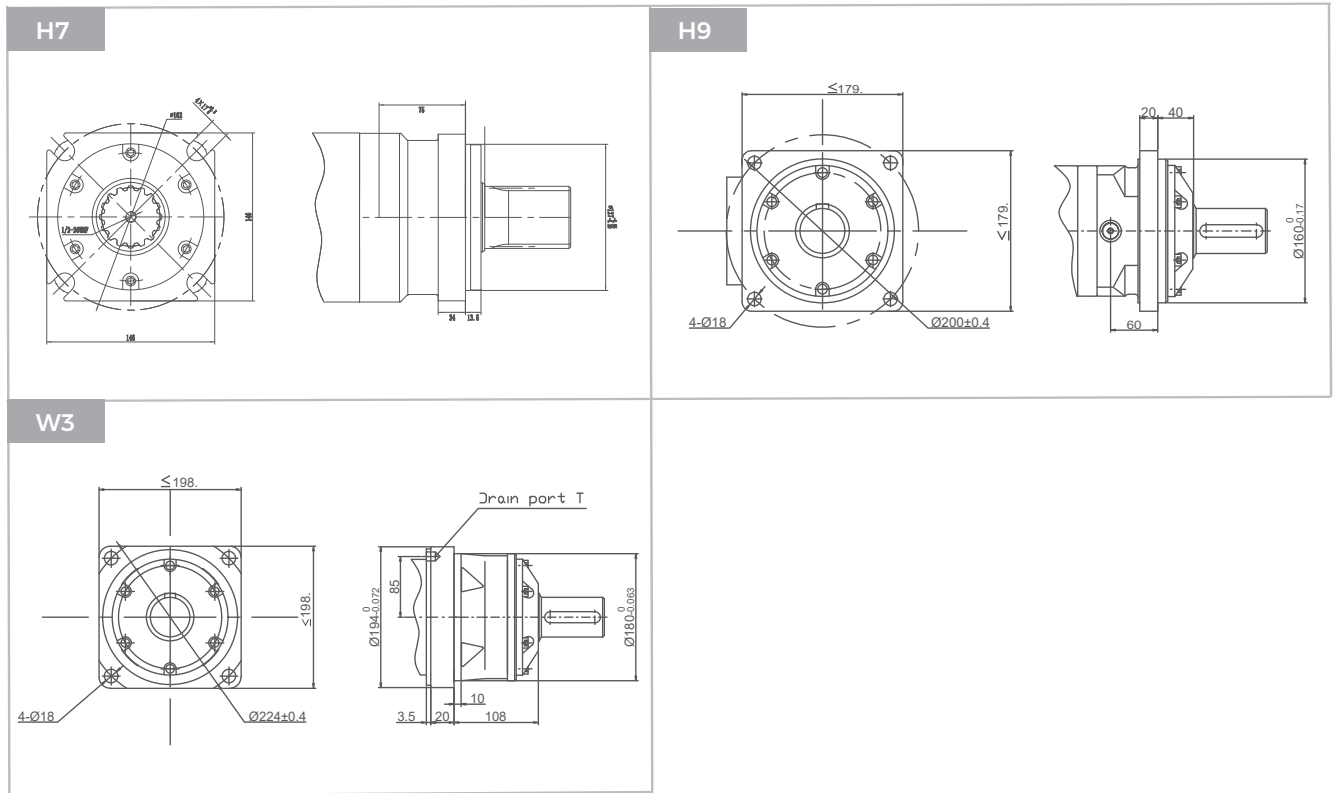

GVS Bearingless Motor Dimensions and Mountings

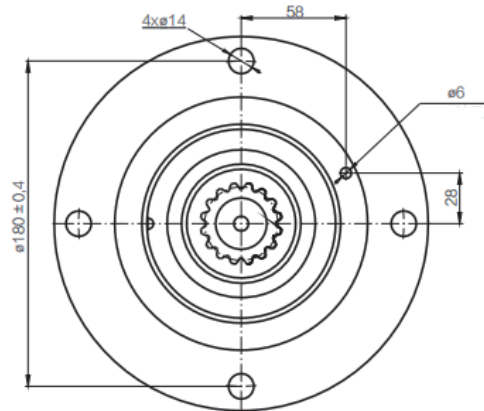
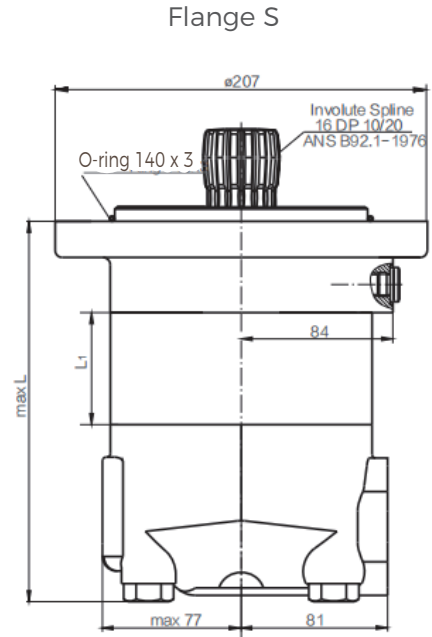
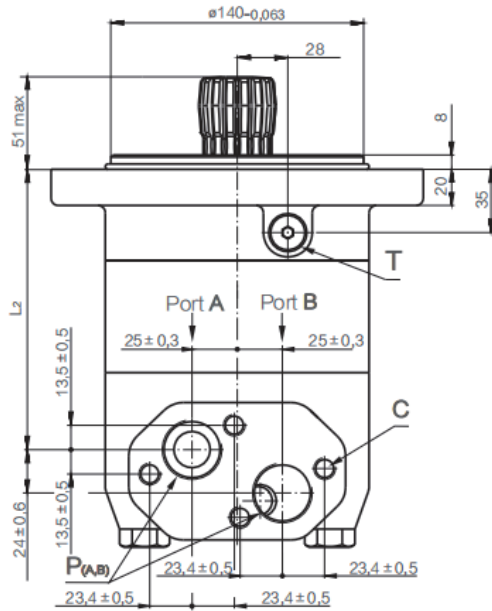

Model	L	L1	L2
GVS315	171	22	117
GVS400	179	29	124
GVS500	186	37	132
GVS630	197	47.5	143
GVS800	211	61.5	157

Mounting	G5 (depth)	M6 (depth)	U6 (depth)	G6 (depth)	M7 (depth)	U7 (depth)
P(A, B)	G1(18)	M33 X 12(18)	1-5/16-12UN(18)	G1(18)	M33 X 2(18)	1-5/16-12UN(18)
T	G1/4(12)	M14 X 1.5(12)	9/16-18UNF(12)	G1/4(12)	M14 X 1.5 (12)	7/16-20UNF(12)
C	4-M12(12)	4-M12(12)				

GV Shafts Dimensions

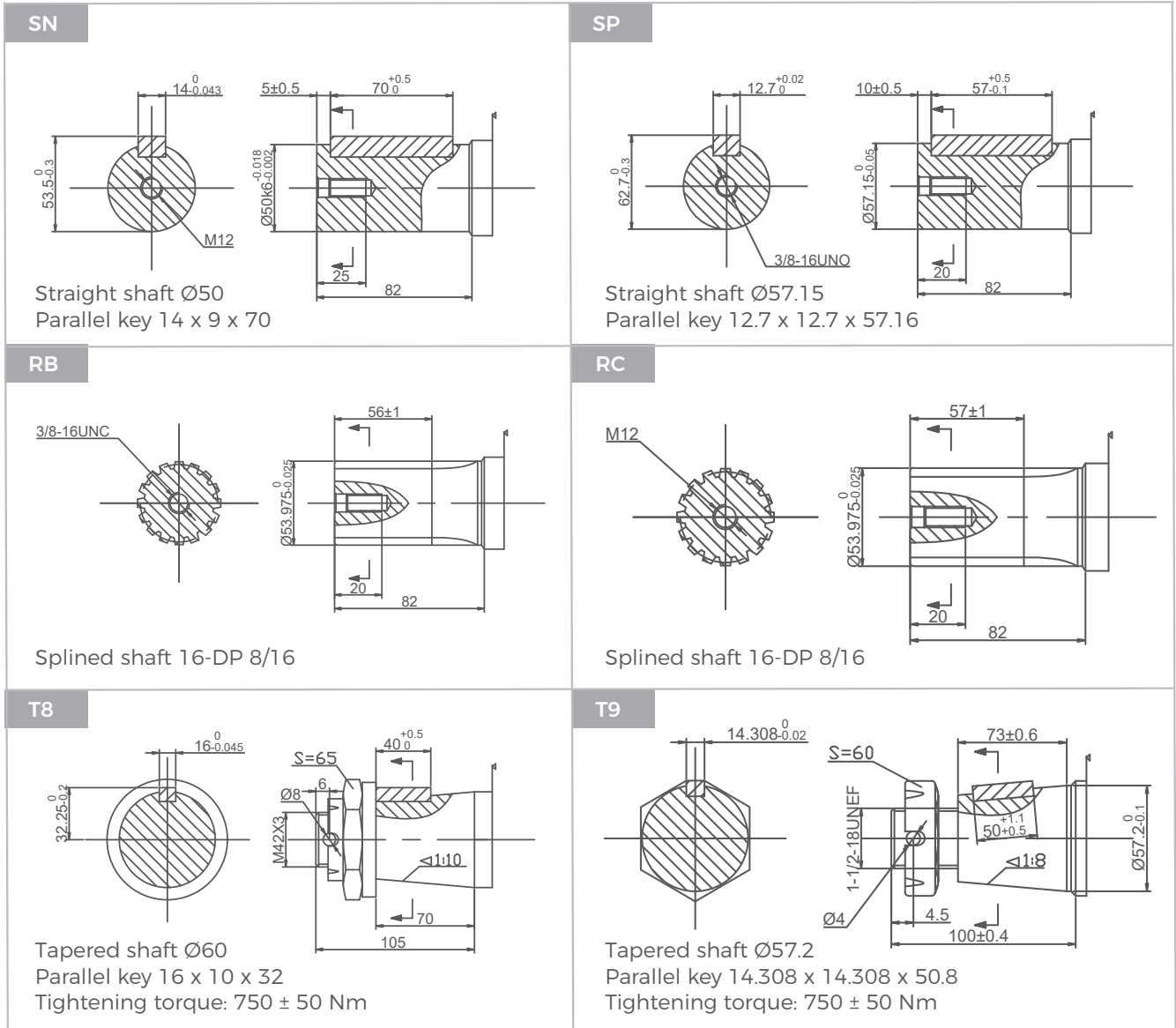

GV Series Hydraulic Motors

Permissible shaft seal pressure

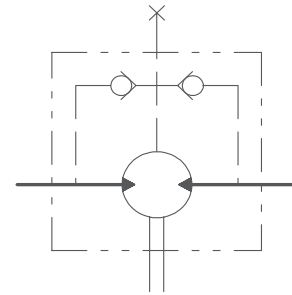
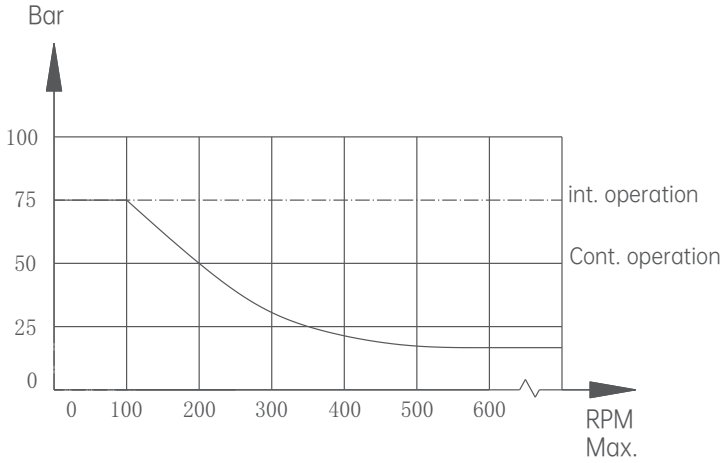

GV with standard shaft seal, check valves and without use of drain connection: The pressure on the shaft seal never exceeds the pressure in the return line.

GV with standard shaft seal, check valves and with drain connection: The shaft seal pressure equals the pressure on the drain line.

Drain Port

In applications without drain line, output shaft seal exceeds a bit of the pressure in the return line. In applications using the drain line, the pressure of output shaft seal equals the pressure in drain line.

Standard direction of shaft rotation: Standard

When facing shaft end of motor, shaft to rotate:
Clockwise when port "A" is pressurized.
Counter-clockwise port "B" is pressurized.

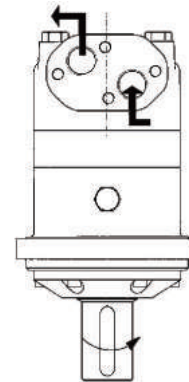

Output shaft stand radial force

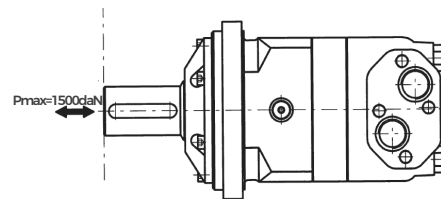
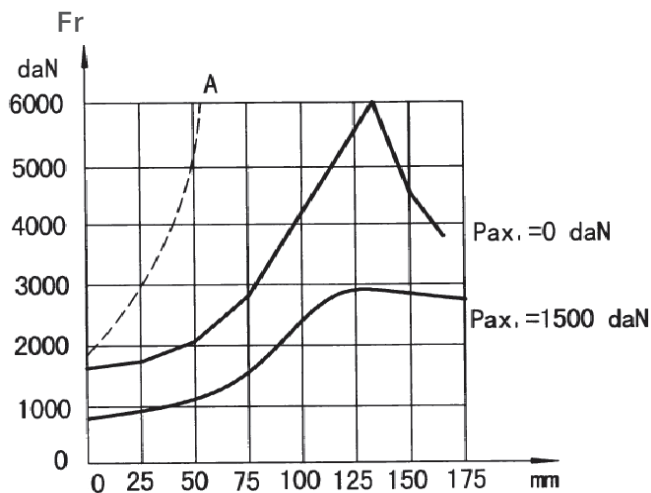

The output shaft runs in tapered bearings that permit high axial and radial forces, Curve "A" shows max radial shaft load, any shaft loads exceeding the values quoted in the curve will involve a risk of breakage, the tow other curves apply to a B10 bearing life of 3000 hours at 200 RPM.

GFA Series Hydraulic Motors

Options

- Flange connection
- Motor with needle roller bearing
- Speed sensing
- Side and rear ports
- Shaft seal for high and low pressure
- Straight, splined and tapered shafts
- Metric and BSPP ports
- Other special features

Applications

- Conveyors
- Feeding machiners
- Metal working machines
- Textile machines
- Agricultural machines
- Food industries
- Lawn mower



General

Max. Displacement	cm ³ /rev [in ³ /rev]	392 [24.0]
Max. Speed	RPM	1141
Max. Torque	daNm [lb-in]	cont.:44,5 [3935] int.:62,8 [5562]
Max. Output	kW [HP]	12.5 [16.8]
Max. Pressure Drop	bar [PSI]	cont.: 140 [2030] int.: 190 [2750]
Max. Oil Flow	lpm [GPM]	75 [20.0]
Pressure fluid		Mineral based- HLP (DIN 51524) or HM (ISO 6743/4)
Temperature Range	°C [°F]	-40÷140 [-40÷284]
Optimal Viscosity range	mm ² /s [SUS]	20÷75 [98÷347]
Filtration		ISO code 20/16 (Min. recommended fluid filtration of 25 microns)

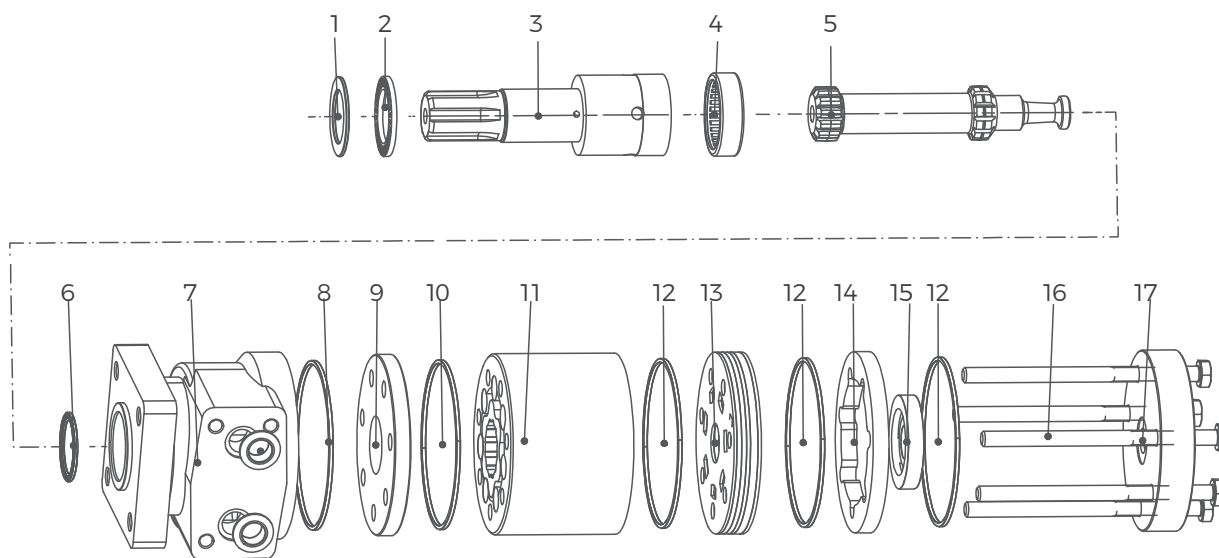

1 Bearing retainer

2 Flat bearing

3 Output shaft

4 Cylindrical needle roller bearing

5 Transmission shaft

6 Anti-dust ring

7 Housing

8 O-ring

9 Spacer

10 O-ring

11 Rotor and stator

12 O-ring

13 Distribution plate

14 Spacer

15 Distribution ring

16 Screw

17 Rear cover

GFA Specifications

Type		GFA36	GFA45	GFA50	GFA65	GFA80
Displacement cm ³ /rev [in ³ /rev]		36[2.2]	41[2.5]	49[3.0]	65[4.0]	82[5.0]
Max. Speed RPM	Int.	1141	1024	1020	877	695
Max. Oil Flow	Cont.	34[9]	34[9]	34[9]	45[12]	45[12]
lpm [GPM]	Int.	42[11]	42[11]	50[13]	57[15]	57[15]
Max. Differential Pressure	Cont.	140[2030]	140[2030]	140[2030]	140[2030]	140[2030]
bar [PSI]	Int.	190[2750]	190[2750]	190[2750]	190[2750]	190[2750]
Max. Supply Pressure bar [PSI]		200[2900]	200[2900]	200[2900]	200[2900]	200[2900]
Max. Torque	cont.	5,46[483]	7,1[624]	9,0[796]	12,5[1106]	16,0[1416]
daNm [lb-in]	int.	7,11[60]	9,9[876]	12,7[1120]	17,6[1558]	22,0[1947]
Max. Performance kW [HP]		8,5[11.4]	10,4[13.9]	12,8[17.2]	14,7[19.8]	17,3[23.2]
Min. Starting Torque	cont.	4,4[389]	4,4[1111]	7,2[637]	10,0[885]	12,8[1133]
daNm[lb-in]	int.	5,2[460]	6,4[565]	9,8[871]	13,7[1211]	17,1[1515]
Weight, kg [lb]		5,93[13.07]	6,03[13.3]	6,12[13.5]	6,26[13.8]	6,35[14.0]

Type		GFA100	GFA0130	GFA165	GFA195	GFA230
Displacement cm ³ /rev [in ³ /rev]		98[6.0]	130[8.0]	163[10.0]	195[11.9]	228[13.9]
Max. Speed RPM	Int.	582	438	348	292	328
Max. Oil Flow	Cont.	45[12]	45[12]	45[12]	45[12]	57[15]
lpm [GPM]	Int.	57[15]	57[15]	57[15]	57[15]	75[20]
Max. Differential Pressure	Cont.	140[2030]	140[2030]	140[2030]	140[2030]	120[1740]
bar [PSI]	Int.	190[2750]	190[2750]	190[2750]	190[2750]	165[2400]
Max. Supply Pressure bar [PSI]		200[2900]	200[2900]	200[2900]	200[2900]	200[2900]
Max. Torque	cont.	19,0[1682]	25,5[2257]	31,0[2744]	39,0[3452]	38,0[3363]
daNm [lb-in]	int.	26,4[2337]	35,2[3116]	43,6[3846]	52,8[4673]	51,4[4554]
Max. Performance kW [HP]		17,4[23.4]	17,3[23.2]	17,0[22.8]	17,4[23.4]	17,7[23.8]
Min. Starting Torque	cont.	15,2[1345]	20,4[1806]	24,8[2195]	31,2[2762]	30,4[2691]
daNm [lb-in]	int.	20,5[1819]	27,4[2423]	33,8[2992]	41,1[3637]	41,1[3637]
Weight, kg [lb]		6,49[14.3]	6,76[14.9]	7,03[15.5]	7,35[16.2]	7,58[16.7]

Specifications

Type		GFA260	GFA295	GFA330	GFA365	GFA390
Displacement cm ³ /rev [in ³ /rev]		260[15.9]	293[17.9]	328[20.0]	370[22.6]	392[24.0]
Max. Speed RPM	Int.	287	256	228	203	191
Max. Oil Flow	Cont.	57[15]	57[15]	57[15]	57[15]	57[15]
lpm [GPM]	Int.	75[20]	75[20]	75[20]	75[20]	75[20]
Max. Differential Pressure	Cont.	110[1595]	100[1450]	100[1450]	95[1378]	85[1233]
bar [PSI]	Int.	155[2250]	145[2100]	135[1950]	125[1825]	120[1740]
Max. Supply Pressure bar [PSI]		200[2900]	200[2900]	200[2900]	200[2900]	200[2900]
Max. Torque	Cont.	40,0[3540]	42,8[3784]	44,3[3926]	46,7[4133]	44,5[3935]
daNm [lb-in]	Int.	55,0[4870]	58,2[5180]	60,0[5312]	64,8[5728]	62,8[5562]
Max. Performance kW [HP]		16,7[22.4]	15,7[21.0]	14,8[19.8]	13,6[18.2]	12,5[16.8]
Min. Starting Torque	Cont.	32,0[2832]	32,8[2903]	33,4[3045]	37,3[3301]	34,8[3080]
daNm [lb-in]	Int.	44,9[3977]	44,5[3939]	45,3[4014]	47,7[4223]	46,2[4090]
Weight, kg [lb]		7.80[17.2]	8.07[17.8]	8.35[18.4]	8.66[19.1]	8.80[19.4]

Function Diagrams

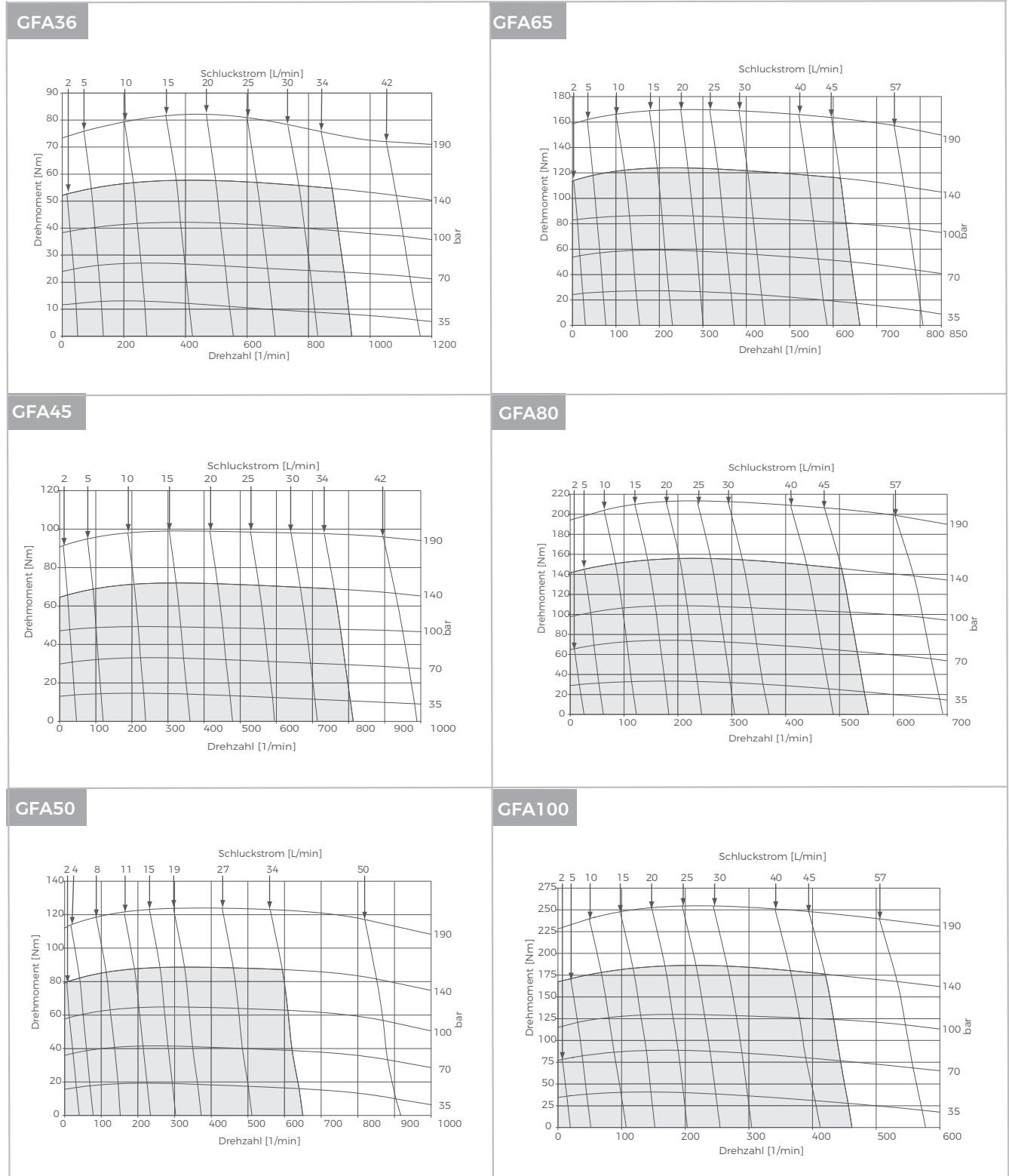

The function diagrams data is for average performance of randomly selected motors at backpressure. 5÷10 bar [72.5÷145 PSI] and oil with viscosity of 32 mm²/s [150 SUS] at 50°C [122°F].

Function Diagrams

GFA130

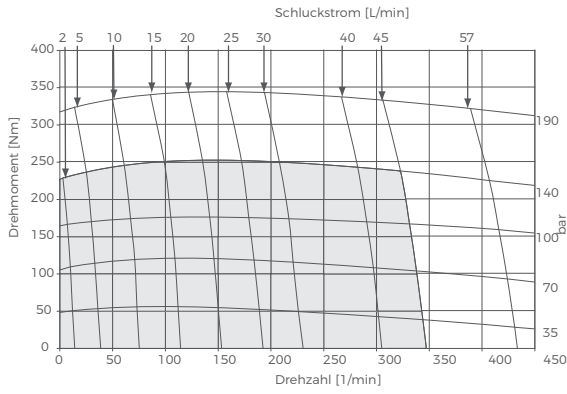

GFA230

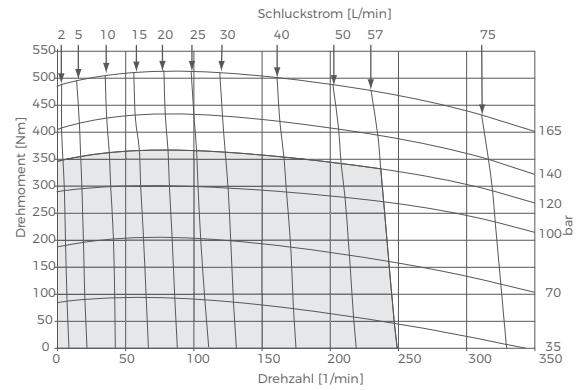

GFA165

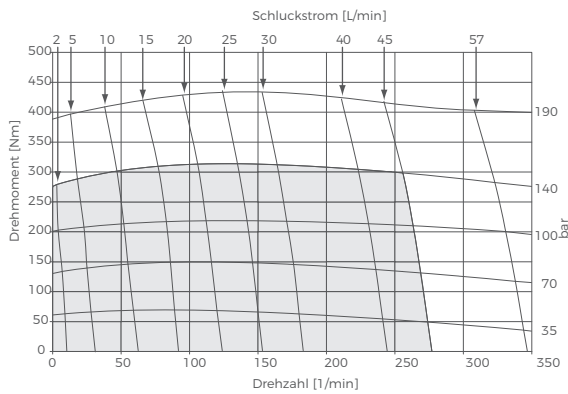

GFA260

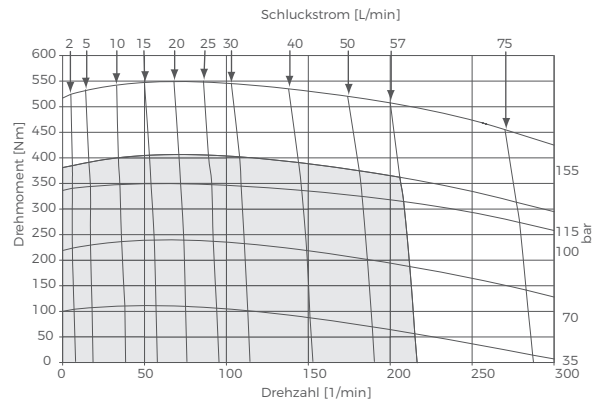

GFA195

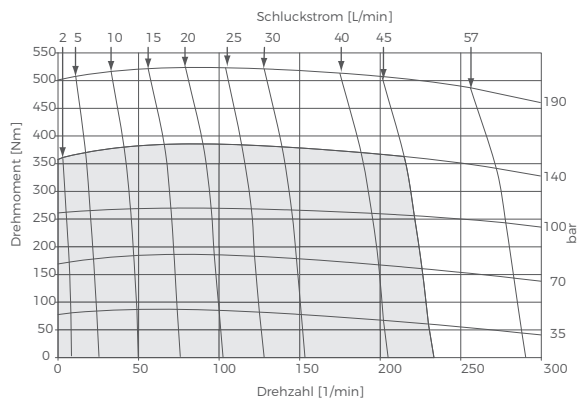

GFA295

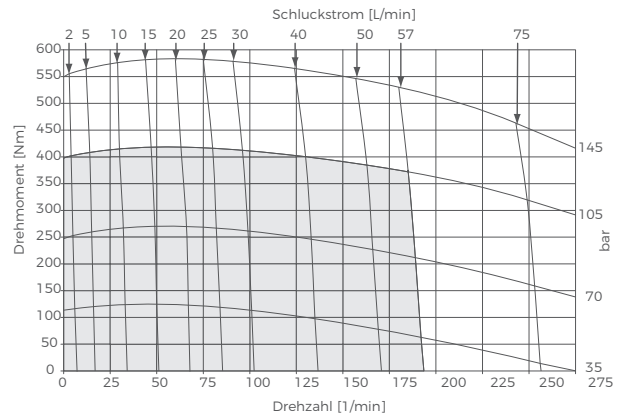

The function diagrams data is for average performance of randomly selected motors at backpressure. 5÷10 bar [72.5÷145 PSI] and oil with viscosity of 32 mm²/s [150 SUS] at 50°C [122°F].

Function Diagrams

CFA330

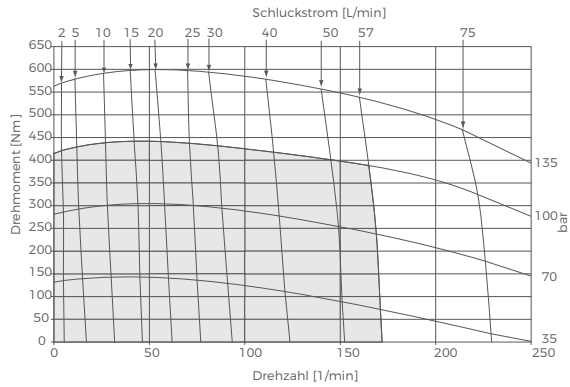

CFA365

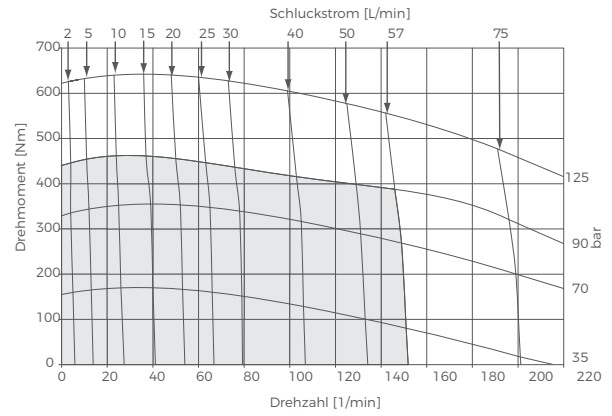

CFA390

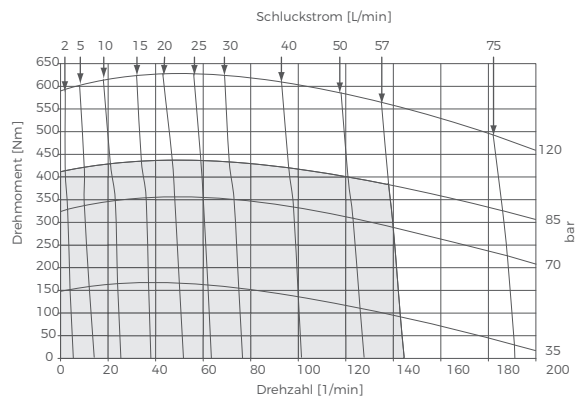

The function diagrams data is for average performance of randomly selected motors at backpressure. 5÷10 bar [72.5÷145 PSI] and oil with viscosity of 32 mm²/s [150 SUS] at 50°C [122°F].

GFA Dimensions and Mountings

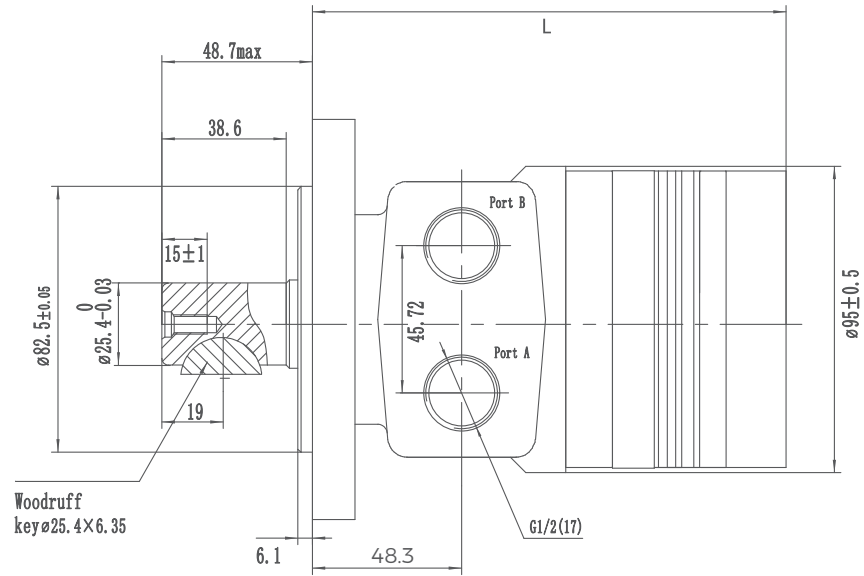

Model	L
GFA36	135
GFA45	136
GFA50	138
GFA65	141
GFA80	144
GFA100	147
GFA130	154
GFA165	160
GFA195	166
GFA230	173
GFA260	179
GFA295	185
GFA330	192
GFA365	200
GFA390	205

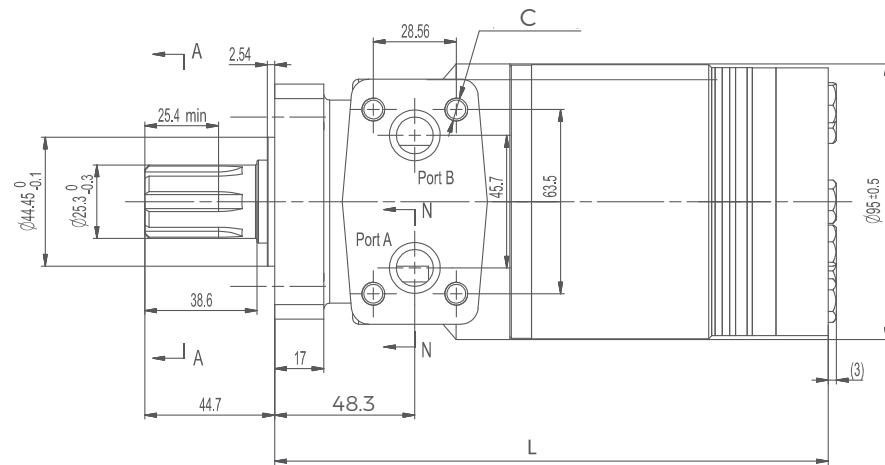

Mounting	G7 (depth)	U9 (depth)	UA (depth)	U3 (depth)	G8 (depth)	D1 (depth)	D2 (depth)
P(A, B)	G1/2(15)	7/8-14 O-ring(17)	1/2-14NPTF(15)	3/4-16 O-ring(15)	PT(RC)1/2(15)	Ø10	Ø10
T	G1/4(12)	7/16-20UNF(12)	7/16-20UNF(12)	7/16-20UNF(12)	PT(RC)1/4(9.7)	7/16-20UNF(12)	G1/4(12)
C	—	—	—	—	—	4-5/16-18UNC(13)	4-M8(13)

GFA Flange Covers Dimensions

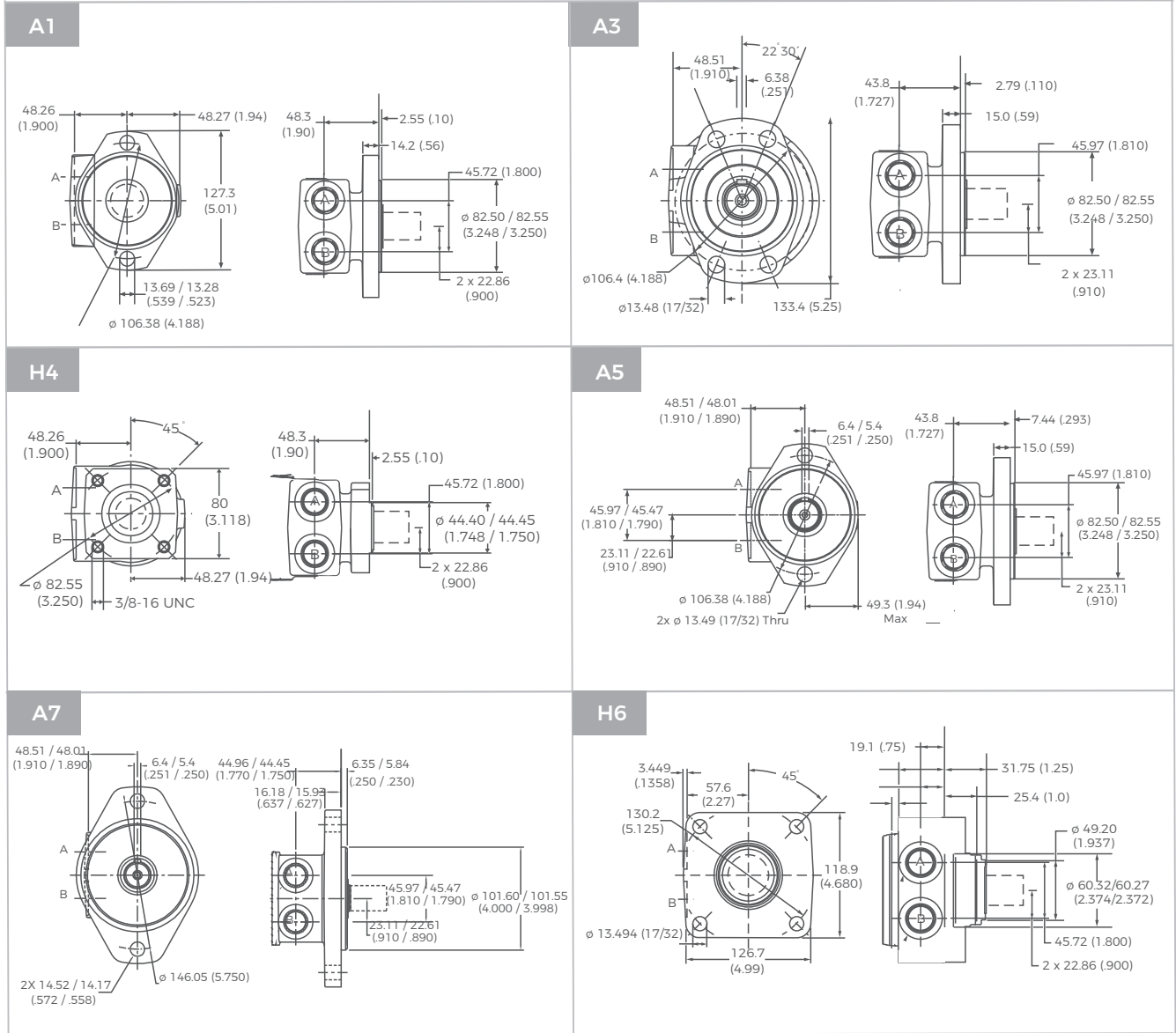

GFA Shafts Dimensions

<p>S6</p> <p>Straight shaft $\varnothing 25.4$ Woodruff key $\varnothing 25.4 \times 6.35$</p>	<p>S9</p> <p>Straight shaft $\varnothing 25.4$ Pin hole $\varnothing 10.3$</p>
<p>R4</p> <p>Splined shaft SAE 6B</p>	<p>SC</p> <p>Straight shaft $\varnothing 25$ Parallel key $8 \times 7 \times 28$</p>
<p>SD</p> <p>Straight shaft $\varnothing 25$ Parallel key $7 \times 7 \times 32$</p>	<p>R5</p> <p>Splined shaft tooth 13-DP 16/32</p>
<p>S7</p> <p>Straight shaft $\varnothing 25$ Parallel key $8 \times 7 \times 32$</p>	<p>SA</p> <p>Straight shaft $\varnothing 25.4$ Pin hole $\varnothing 8$</p>

GFA Shafts Dimensions

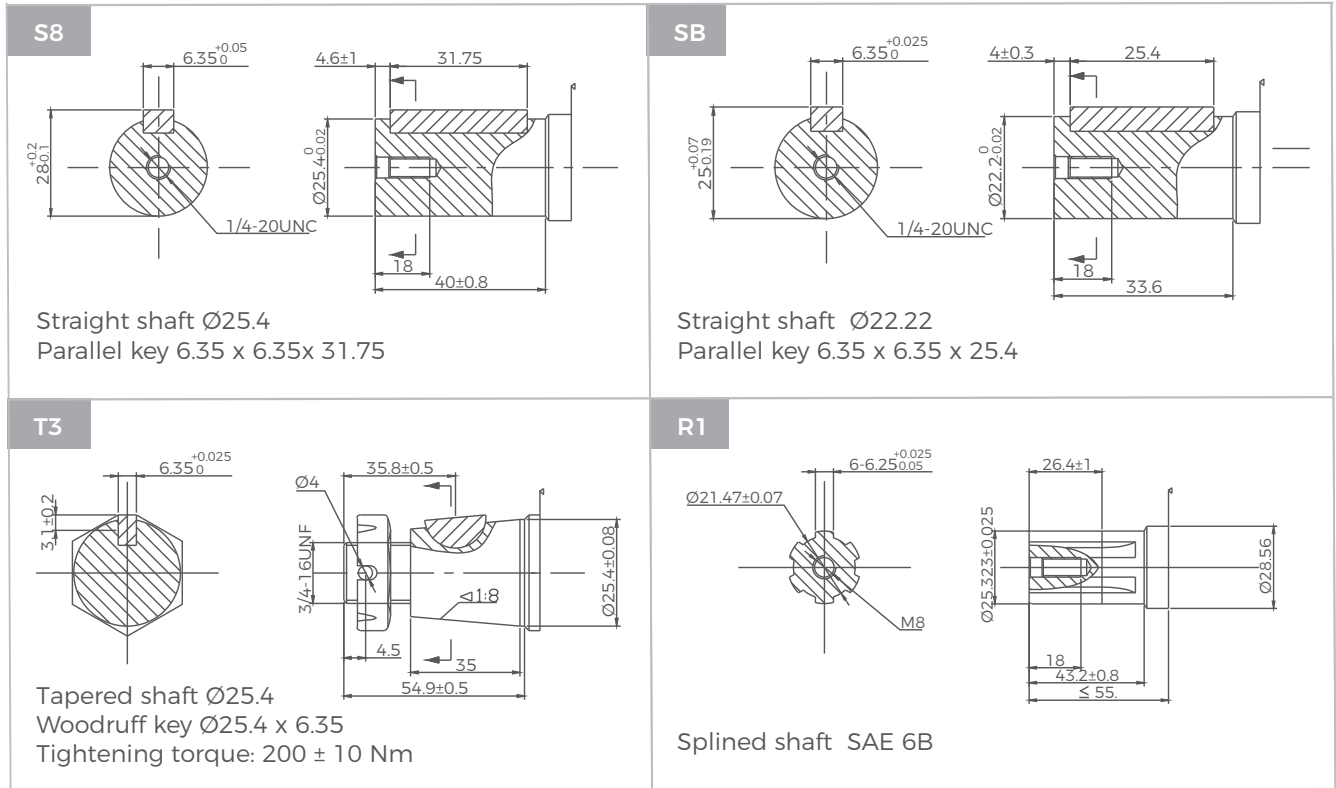

GGM Series Hydraulic Motors

Options

- Gerotor design
- Side ports, rear ports
- Straight, splined shafts
- SAE ports
- Roller bearings for long life
- High pressure mechanical seals

Applications

- Construction machines
- Refuse/dump truck
- Material handling
- Forestry machines
- Agriculture machines
- Industrial machines



General

Max. Displacement	cm ³ /rev [in ³ /rev]	11.47 [.700]
Max. Speed	RPM	5000
Max. Torque 1000 PSI	in.-lbs [kg-cm]	111 [128]
Max. Output	kW [HP]	64 [85.8]
Max. Pressure Drop	bar [PSI]	cont.: 138 [2000] int.: 172.58 [2500]
Max. Oil Flow	lpm [GPM]	56.7[15]
Max. Shaft Side Loads	lbs. [kg]	170 [77]
Pressure fluid		Mineral based- HLP (DIN 51524) or HM (ISO 6743/4)
Temperature Range	°C [°F]	-40÷140 [-40÷284]
Optimal Viscosity range	mm ² /s [SUS]	20÷75 [98÷347]
Filtration		ISO code 20/16 (Min. recommended fluid filtration of 25 microns)

When used in series, the back pressure shall not exceed 69bar.

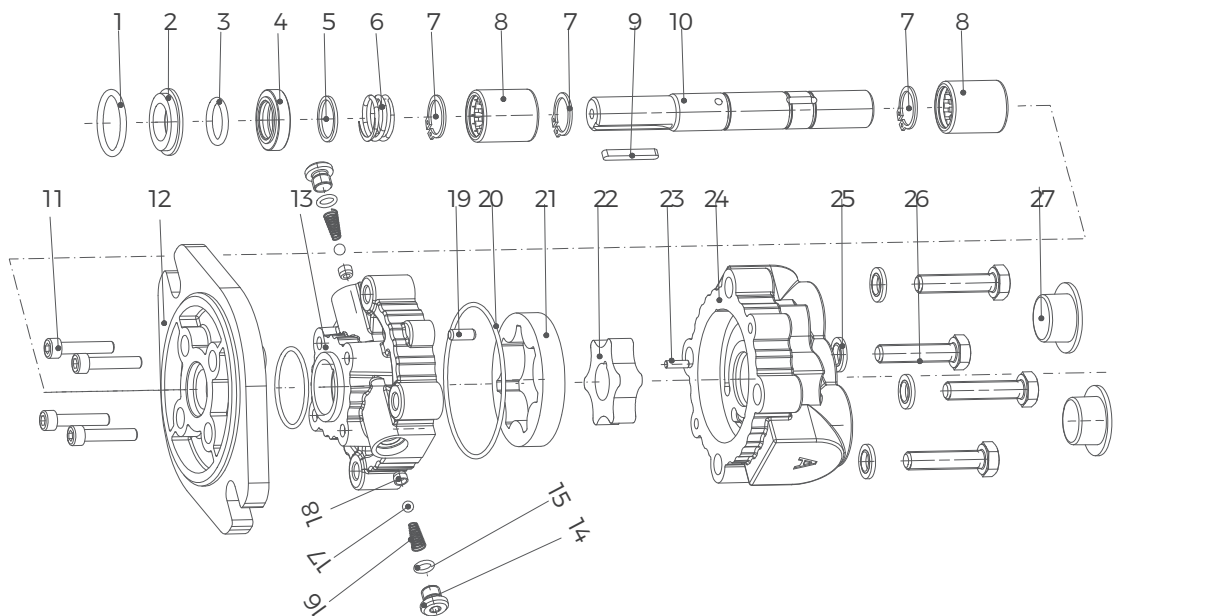

1 O-ring	7 Non-standard clamp	13 Intermediate	19 Positioning pins	25 Washer
2 Mechanical static ring	8 Needle roller bearing	14 Plug	20 O-ring	26 Bolt
3 O-ring	9 Parallel Key	15 O-ring	21 Inner rotor	27 Oil port plug cap
4 Mechanical dynamic ring	10 Transmission shaft	16 Spring	22 Outer rotor	
5 Washer	11 Screw	17 Steel ball	23 Cylindrical pin	
6 Compression spring	12 Front cover	18 Valve base	24 Rear cover	

Specifications

Type	GGM3.6	GGM6.1	GGM7.4
Displacement in ³ /rev [cm ³ /rev]	.218(3.57)	.372(6.094)	.450(7.374)
Max. Rated RPM	5000	5000	5000
Rated Flow Per 1000 RPM (Nominal)	.95GPM(3.6 L/min)	1.61GPM(6.1 L/min)	1.95GPM(7.4 L/min)
Max. Continuous Pressure	2000PSI(138.0 bar)	2000PSI(138.0 bar)	2000PSI (138.0 bar)
Max. Intermittent Pressure	2500PSI(172.5 bar)	2500PSI(172.5 bar)	2500PSI (172.5 bar)
Output Torque Per 1000 PSI (69.0 bar)	35 in.-lbs (40 kg-cm)	59 in.-lbs (68 kg-cm)	72 in.-lbs. (83 kg-cm)
Weight	2.8 pounds(1.25 kg)	3.0 pounds(1.36 kg)	3.1 pounds(1.41 kg)
Shaft Side Load**	170 lbs(77.0 kg)	130 lbs.(59.0 kg)	110 lbs.(50.0 kg)

Type	GGM9.5	GGM11.5
Displacement in ³ /rev [cm ³ /rev]	.580(9.50)	.700(11.471)
Max. Rated RPM	5000	5000
Rated Flow Per 1000 RPM (Nominal)	2.51GPM(9.5 L/min)	3.03GPM(11.5 L/min)
Max. Continuous Pressure	2000PSI (138.0 bar)	1500PSI (103.5 bar)
Max. Intermittent Pressure	2500PSI (172.5 bar)	2000PSI (138.0 bar)
Output Torque Per 1000 PSI (69.0 bar)	92 in.-lbs. (107 kg-cm)	111 in.-lbs (128 kg-cm)
Weight	3.3 pounds(1.50 kg)	3.5 pounds(1.59 kg)
Shaft Side Load**	70 lbs.(31.7 kg)	30 lbs.(13.5 kg)

* THEORETICAL

** SIDE LOAD: Maximum Permissible Shaft Side Load at 2500 RPM and 1000 PSI (69.0 bar)
(B-10 Bearing Life of 1000 Hrs.)

OIL TEMPERATURE: Maximum recommended oil temperature 180° F (82.2° C)

OIL VISCOSITY: Recommended viscosity 150 SUS (3.65 engler).

(32 centistokes) Minimum recommended viscosity

60 SUS (2.1 engler) (13 centistokes)

FILTRATION: Minimum recommended filtration 10 Micron.

END THRUST: 80 Lbs. (36.3 kg.) maximum.

Function Diagrams

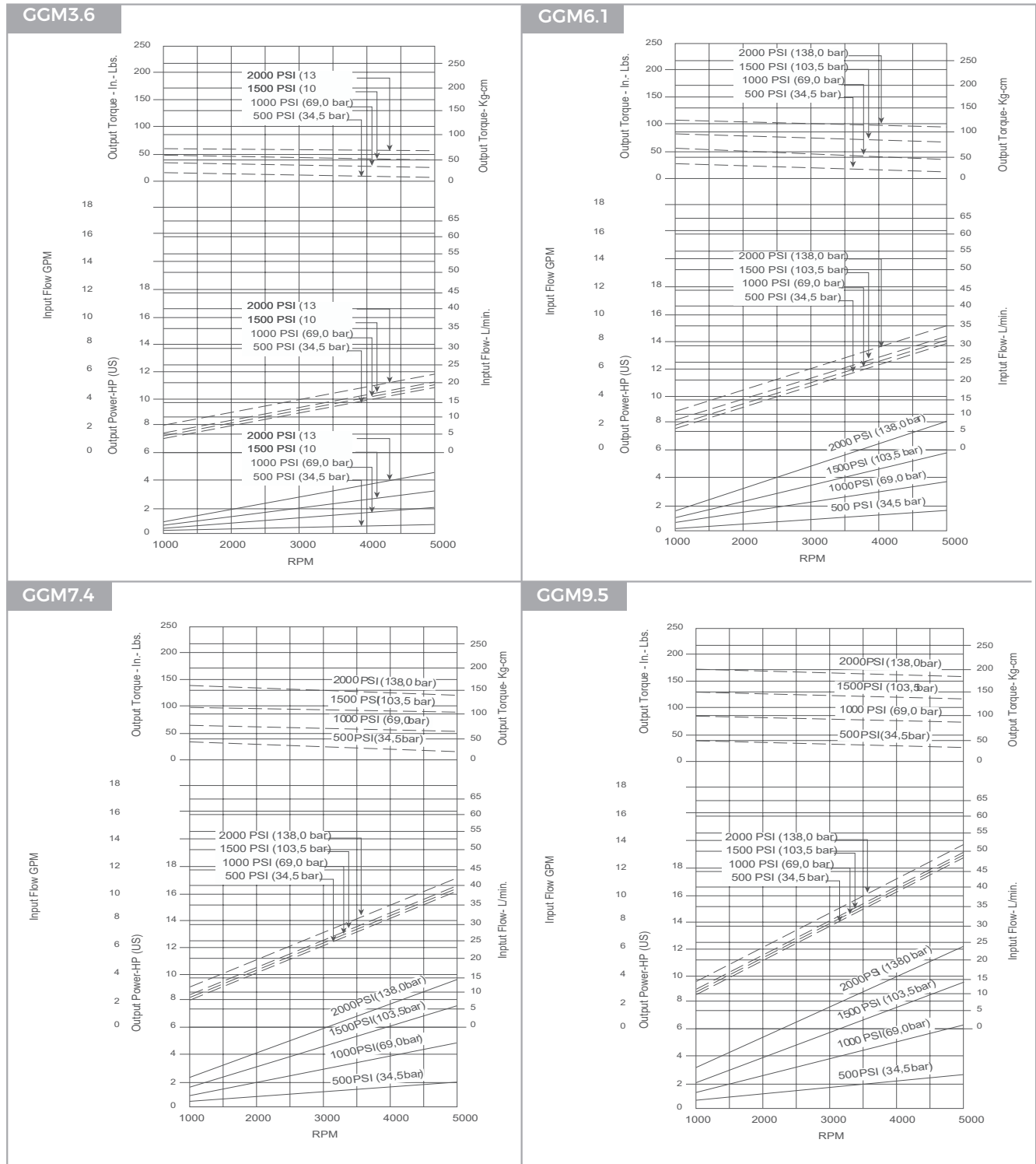

Function Diagrams

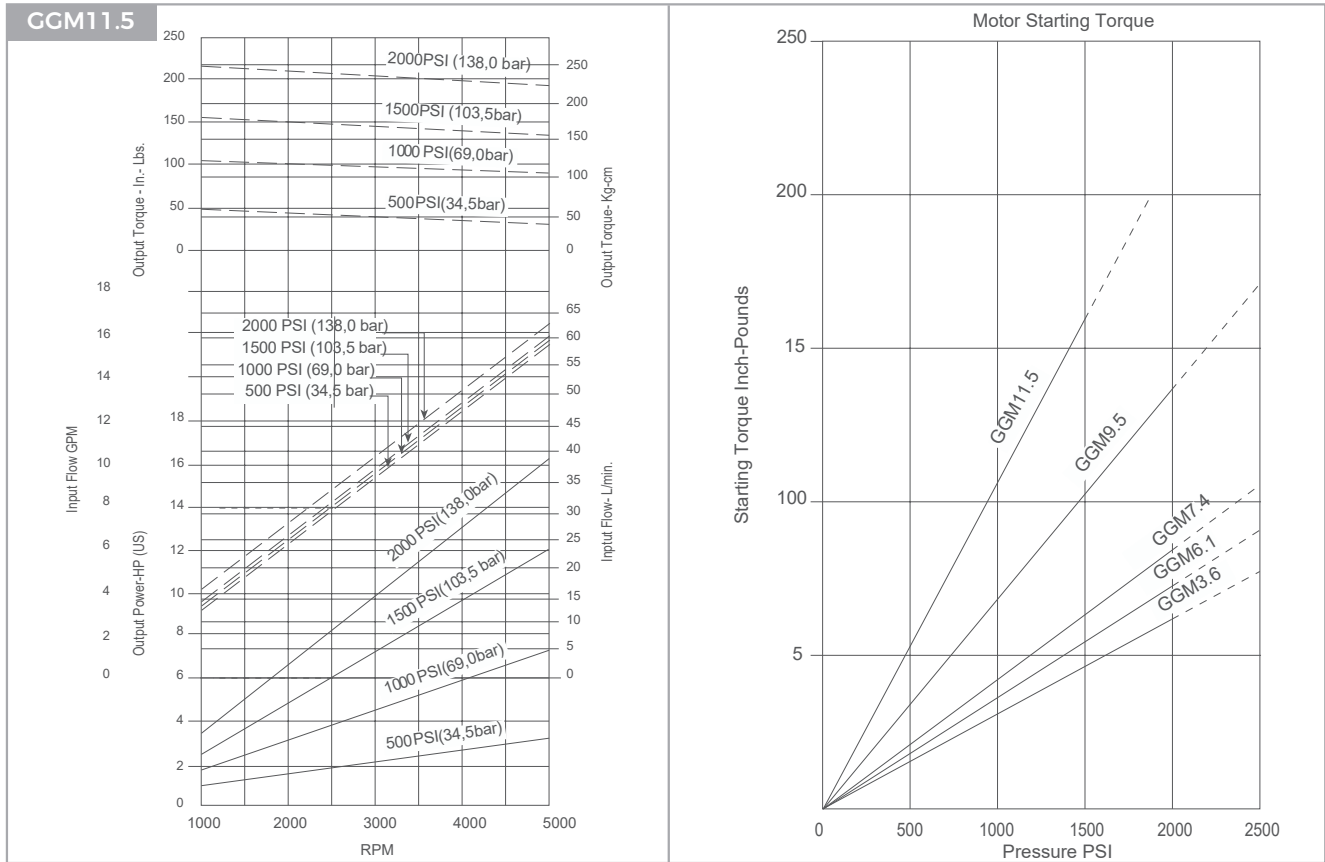

GGM Dimensions and Mountings

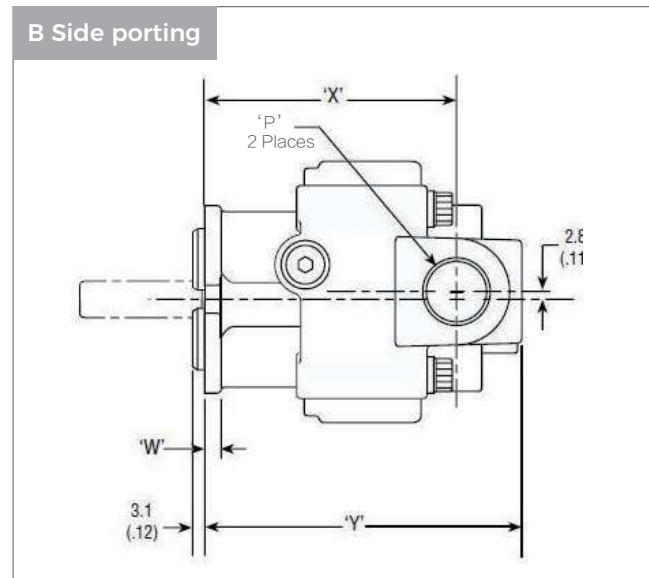
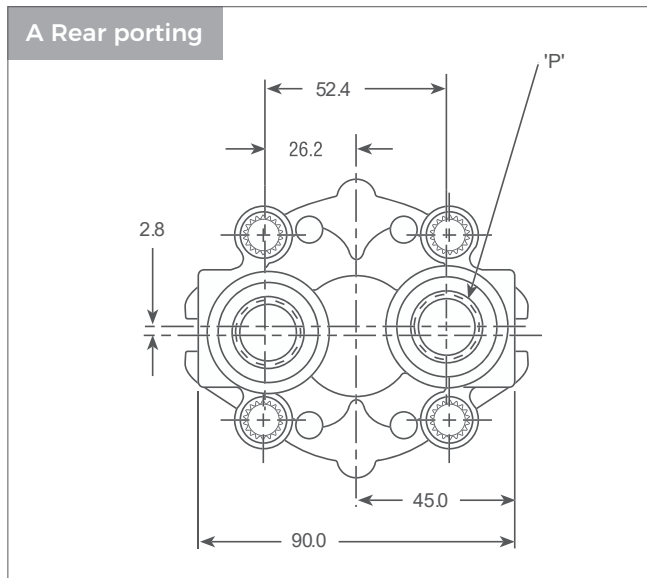

Model	Size	
	"X"	"Y"
GGM3.6	73.1(2.88)	93.1(3.67)
GGM6.1	77.3(3.04)	97.3(3.83)
GGM7.4	79.4(3.13)	99.4(3.91)
GGM9.5	83.0(3.27)	103.0(4.06)
GGM11.5	86.3(3.40)	106.3(4.19)

Flange	"W"
2 holes "A-A"	6.3
4 holes	6.3
2 holes "A"	9.5

Model	"P" SAE Straight thread oil port, O-ring seal
GGM3.6	SAE 8(3/4-16UNF)
GGM6.1	SAE 8(3/4-16UNF)
GGM7.4	SAE 8(3/4-16UNF)
GGM9.5	SAE 10(7/8-14UNF)
GGM11.5	SAE 10(7/8-14UNF)

GGM Flange Covers Dimensions

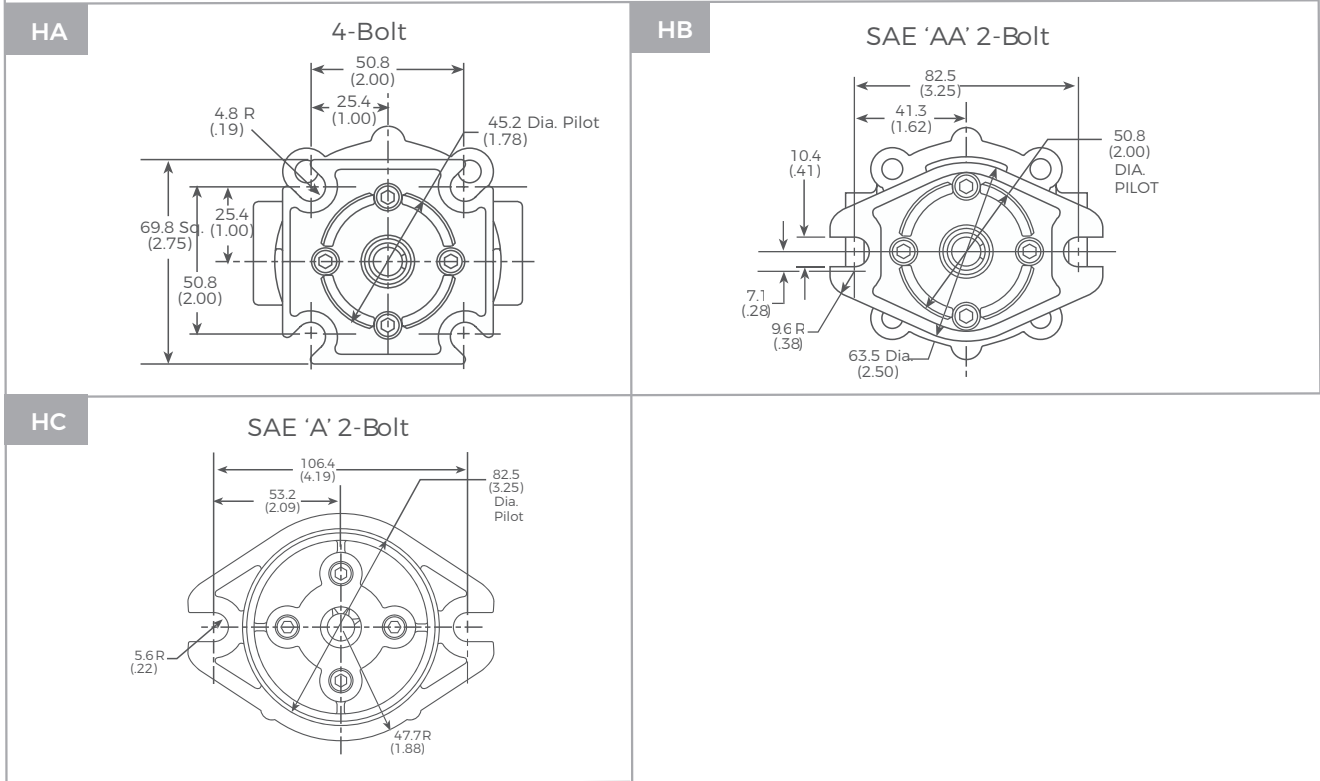

GGM Shafts Dimensions

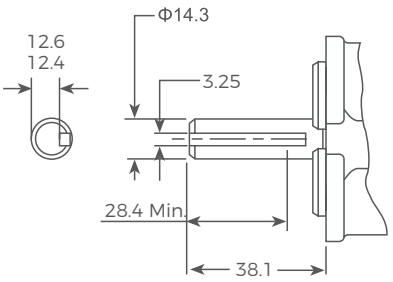
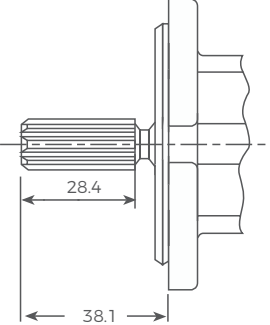
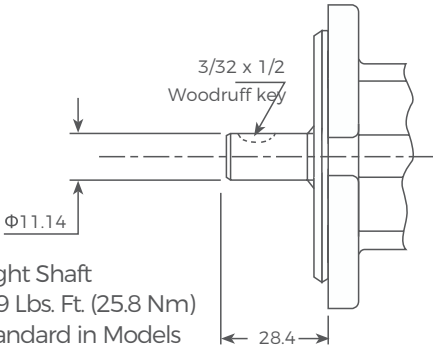
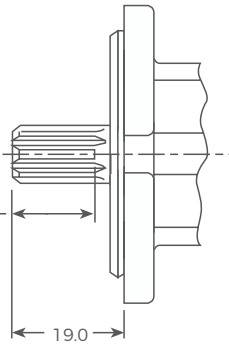
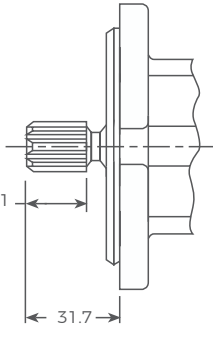
<p>SQ</p>  <p>Diameter 9/16, Straight shaft Maximum bearing torque 52.9 Nm</p>	<p>RD</p>  <p>9/16 Dia. 8 Tooth Splined Shaft Flat Root Side Fit-Class 2 Fit Torque Limit 39 Lbs. Ft. (52.9 Nm)</p>
<p>SR</p>  <p>7/16 Dia. Straight Shaft Torque Limit 19 Lbs. Ft. (25.8 Nm) Available as Standard in Models</p>	<p>RG</p>  <p>9/16 Dia. 8 Tooth Splined Shaft Flat-Root Side Fit-Class 2 Fit Torque Limit 39 Lbs. Ft. (52.9 Nm) Available as Standard in Models</p>
<p>RF</p>  <p>5/8 Dia. 9 Tooth Splined Shaft Flat Root Side Fit - Class 1 Fit Torque Limit 52 Lbs. Ft. (70.5 Nm) Available as Standard in Models</p>	

GKA Series Hydraulic Motors

Options

- Flange and circle
- Bearingless motor
- Motor with brake
- Tacho connection
- Speed sensing
- Side and rear ports
- Straight, splined and tapered shafts
- Shaft seal for high and low pressure
- Metric and BSPP ports
- Other special features

Applications

- Conveyors
- Road building machines
- Metal working machines
- Special vehicles
- Agricultural machines
- Food industries
- Mining machines







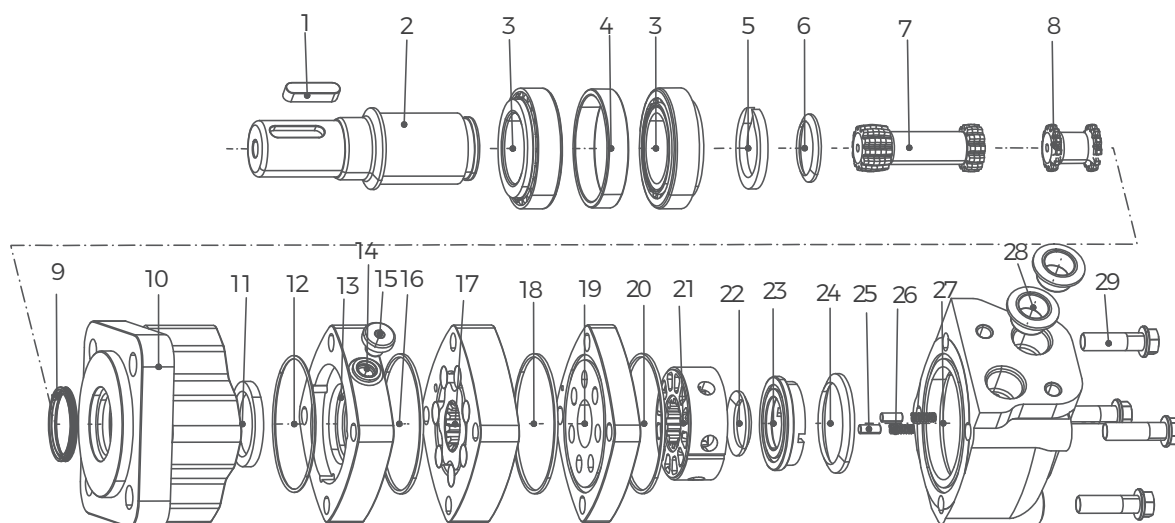







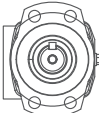

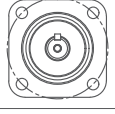

General

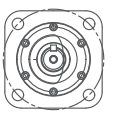
Max. Displacement	cm ³ /rev [in ³ /rev]	490 [29.8]
Max. Speed	RPM	1215
Max. Torque	daNm [lb-in]	cont.: 84,5 [7470] int.: 93,0 [8225]
Max. Pressure Drop	bar [PSI]	cont.: 205 [3000] int.: 310 [4500]
Max. Oil Flow	lpm [GPM]	150 [30]
Pressure Fluid		Mineral based- HLP (DIN 51524) or HM (ISO 6743/4)
Temperature Range	°C [°F]	-40÷140 [-40÷284]
Optimal Viscosity range	mm ² /s [SUS]	20÷75 [98÷347]
Filtration		ISO code 20/16 (Min. recommended fluid filtration of 25 microns)



- | | | | | |
|--------------------------|----------------------|-----------------------|----------------------------|----------------------|
| 1 Parallel Key | 7 Transmission shaft | 13 Connecting body | 19 Balance plate | 25 Positioning pins |
| 2 Output shaft | 8 Coupling shaft | 14 Sealing gasket | 20 Special shape ring | 26 Spring |
| 3 Tapered roller bearing | 9 Anti-dust ring | 15 Plug | 21 Flow distribution plate | 27 Rear housing |
| 4 Bearing retainer ring | 10 Front Cover | 16 O-ring | 22 Special shape ring | 28 Oil port plug cap |
| 5 Washers | 11 Shaft seal | 17 Rotor and stator | 23 Flow pressure plate | 29 Screw |
| 6 Special shape ring | 12 O-ring | 18 Special shape ring | 24 Special shape ring | |

Ordering Code

CKA SERIES		DISP	FLANGE		SHAFT	PORTS		ROTATION	PAINT		FUNCTION	
CODE		DISP	CODE	FLANGE		CODE	PORTS		CODE	PAINT	CODE	FUNCTION
34		34cm ³ /rev [2.1in ³ /rev]	A7	2-Hole SAE A pilot Ø82.5×6.4 		G7	G1/2, G1/4		A	No paint	A	Standard
41		41cm ³ /rev [2.5in ³ /rev]				DU	G1/2, 7/16-20 UNF		B	Blue	N	Big radial force
66		66cm ³ /rev [4.0in ³ /rev]				U9	7/8-14 O-ring, 7/16-20 UNF		C	Black	D	No case drain
80		80cm ³ /rev [4.9in ³ /rev]	H3	4- Ø13.5 Hole Square pilot Ø82.5×6.4 		SB	7/8-14, O-ring G1/4		S	Silver grey	F	Free running
90		90cm ³ /rev [5.5in ³ /rev]				M4	M22x1.5, M14x1.5				L	Low speed
100		100cm ³ /rev [6.2in ³ /rev]				MU	Ø12.7, Ø15.8, 7/16-20 UNF manifold 3x3/8-16 UNC				V	High temp.
130		130cm ³ /rev [8.0in ³ /rev]	A9	4-Hole SAE A pilot Ø82.5×6.4 		MM	Ø12.7Ø15.8, G1/4 manifoldM10x1				S	Low temp.
160		160cm ³ /rev [9.6in ³ /rev]						CODE	SHAFT			
195		195cm ³ /rev [11.9in ³ /rev]				R6	Ø31.25 Splined 14-DP 12/24 	R6	Ø31.25 Splined 14-DP 12/24			
245		245cm ³ /rev [14.9in ³ /rev]				S6	Ø25.4 woodruff key Ø25.4×6.35 	S6	Ø25.4 woodruff key Ø25.4×6.35			
						R8	Ø25.4 splined SAE 6B 	R8	Ø25.4 splined SAE 6B			
			W1	4- Ø13.5 Hole Square pilot Ø107.95×46.5 		S1	Ø25 parallel key 8×7×32 	S1	Ø25 parallel key 8×7×32			
						R5	Ø22 Splined 13-DP 16/32 	R5	Ø22 Splined 13-DP 16/32			
			W2	4- Ø13 Hole Square pilot Ø100×6.5 		S4	Ø32 parallel key 10×8×45 	S4	Ø32 parallel key 10×8×45			
						T2	Tapered Ø31.75 parallel key 7.96×7.96×25.4 	T2	Tapered Ø31.75 parallel key 7.96×7.96×25.4			
						SG	Ø31.75 parallel key 7.96×7.96×31.75 	SG	Ø31.75 parallel key 7.96×7.96×31.75			
						A1	Ø25 parallel key 8×7×2 	A1	Ø25 parallel key 8×7×2			
						N	Ø30 Splined 6-30×25×6 	N	Ø30 Splined 6-30×25×6			
						Z	Ø32 Splined 6-32×26×6 	Z	Ø32 Splined 6-32×26×6			
						J	Ø30 Splined 6-30×25×8 	J	Ø30 Splined 6-30×25×8			
								CODE	ROTATION			
								A	Standard			
								R	Opposite			

Specifications

Type		GKA34	GKA41	GKA66	GKA80	GKA90
Displ. cm ³ /rev [in ³ /rev]		34[2.1]	41[2.5]	66[4.0]	80[4.9]	90[5.5]
Max. Speed	Cont.	1215	1104	1075	908	836
RPM	Int.*	1215	1216	1214	908	1042
Flow	Cont.	42[11]	45[12]	72[19]	75[20]	75[20]
lpm [GPM]	Int.*	42[11]	53[14]	87[23]	75[20]	95[25]
Torque	Cont.	9.8[864]	11.2[988]	18.6[1643]	23.5[2065]	26.5[2326]
daNm [lb - in]	Int.*	14.2[1261]	16.9[1497]	27.6[2446]	34.5[3035]	39.0[3458]
Pressure	Cont.	205[3000]	205[3000]	205[3000]	205[3000]	205[3000]
bar [PSI]	Int.*	310[4500]	310[4500]	310[4500]	310[4500]	310[4500]
	Peak**	310[4500]	310[4500]	310[4500]	310[4500]	310[4500]
Weight kg [lb]	Standard or Wheel mount	8.8[19.4]	8.8[19.4]	8.8[19.4]	9.3[20.5]	9.3[20.5]
	Bearingless	6.8[15.0]	6.8[15.0]	6.8[15.0]	7.3[16.0]	7.3[16.0]

Type		GKA100	GKA130	GKA160	GKA195	GKA245
Displ. cm ³ /rev [in ³ /rev]		100[6.2]	130[8.0]	160[9.6]	195[11.9]	245[14.9]
Max. Speed	Cont.	742	576	477	385	308
RPM	Int.*	924	720	713	577	462
Flow	Cont.	75[20]	75[20]	75[20]	75[20]	75[20]
lpm [GPM]	Int.*	95[25]	95[25]	115[30]	115[30]	115[30]
Torque	Cont.	29.5[2630]	38.5[3420]	45.5[4040]	54.0[4780]	66.0[5850]
daNm [lb - in]	Int.*	44.5[3950]	56.0[4970]	57.0[5040]	66.5[5890]	82.0[7250]
Pressure	Cont.	205[3000]	205[3000]	205[3000]	205[3000]	205[3000]
bar [PSI]	Int.*	310[4500]	310[4500]	260[3750]	260[3750]	260[3750]
	Peak**	310[4500]	310[4500]	310[4500]	310[4500]	310[4500]
Weight kg [lb]	Standard or Wheel mount	9.5[21.0]	9.8[21.5]	10.0[22.0]	10.4[23.0]	11.3[25.0]
	Bearingless	7.5[16.5]	7.7[17.0]	7.9[17.5]	8.4[18.5]	9.3[20.5]

Type		GKA305	GKA395	GKA490
Displ. cm ³ /rev [in ³ /rev]		305[18.7]	395[24.0]	490[29.8]
Max. Speed	Cont.	246	191	153
RPM	Int.*	265	335	230
Flow	Cont.	75[20]	75[20]	75[20]
lpm [GPM]	Int.*	115[30]	115[30]	115[30]
Torque	Cont.	76.5[6750]	77.5[6840]	84.5[7470]
daNm [lb - in]	Int.*	88.5[7820]	92.5[2250]	93.6[8225]
Pressure	Cont.	205[3000]	155[2250]	120[1750]
bar [PSI]	Int.*	240[3500]	190[2750]	140[2000]
	Peak**	310[4500]	225[3250]	170[2500]
Weight kg [lb]	Standard or Wheel mount	11.3[25.0]	11.8[26.0]	12.2[27.0]
	Bearingless	9.3[20.5]	9.8[21.5]	10.2[22.5]

GKA Dimensions and Mountings

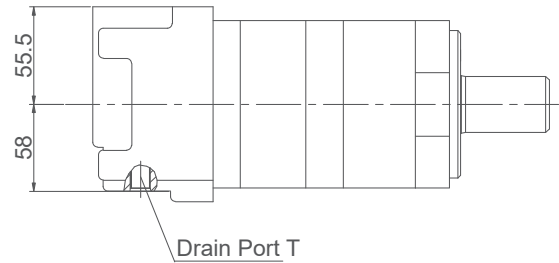
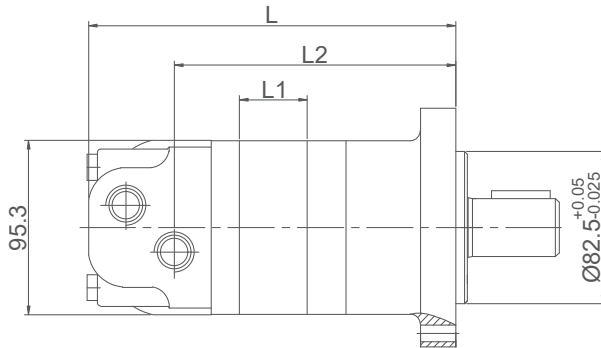

Model	L	L1	L2
GKA34	182	14.5	133.5
GKA41	185	17.8	136.5
GKA66	189.5	22.5	141.5
GKA80	196	28.9	148
GKA90	196	28.9	148
GKA100	202.5	35.6	154.5
GKA130	211.5	44.6	163.5
GKA160	223	56	175
GKA195	235.3	72	188.3
GKA245	256.5	89.3	208.5
GKA305	277.8	107.8	212.5
GKA395	296.5	125.5	237.5
GKA490	313.8	142.3	245

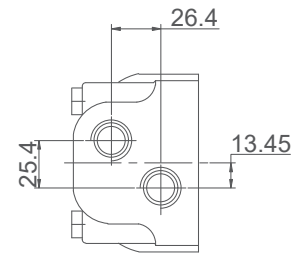
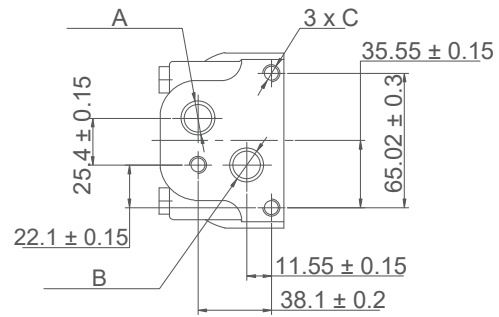

Mounting	G7 (depth)	DU (depth)	U9 (depth)	SB (depth)	M4 (depth)	MU (depth)	MM (depth)
P(A, B)	G1/2 (15)	G1/2 (15)	7/8-14 O-ring (17)	7/8-14 O-ring (17)	M22 x 1.5 (15)	Ø12.7, Ø158	Ø12.7, Ø158
T	G1/4(12)	7/16-20 UNF (12)	7/16-20 UNF (12)	G1/4 (12)	M14 x 1.5 (12)	7/16-20 UNF (12)	G1/4 (12)
C	—	—	—	—	—	3/8-16 UNC (15)	M10 x 1(15)

GKA Flange Covers Dimensions

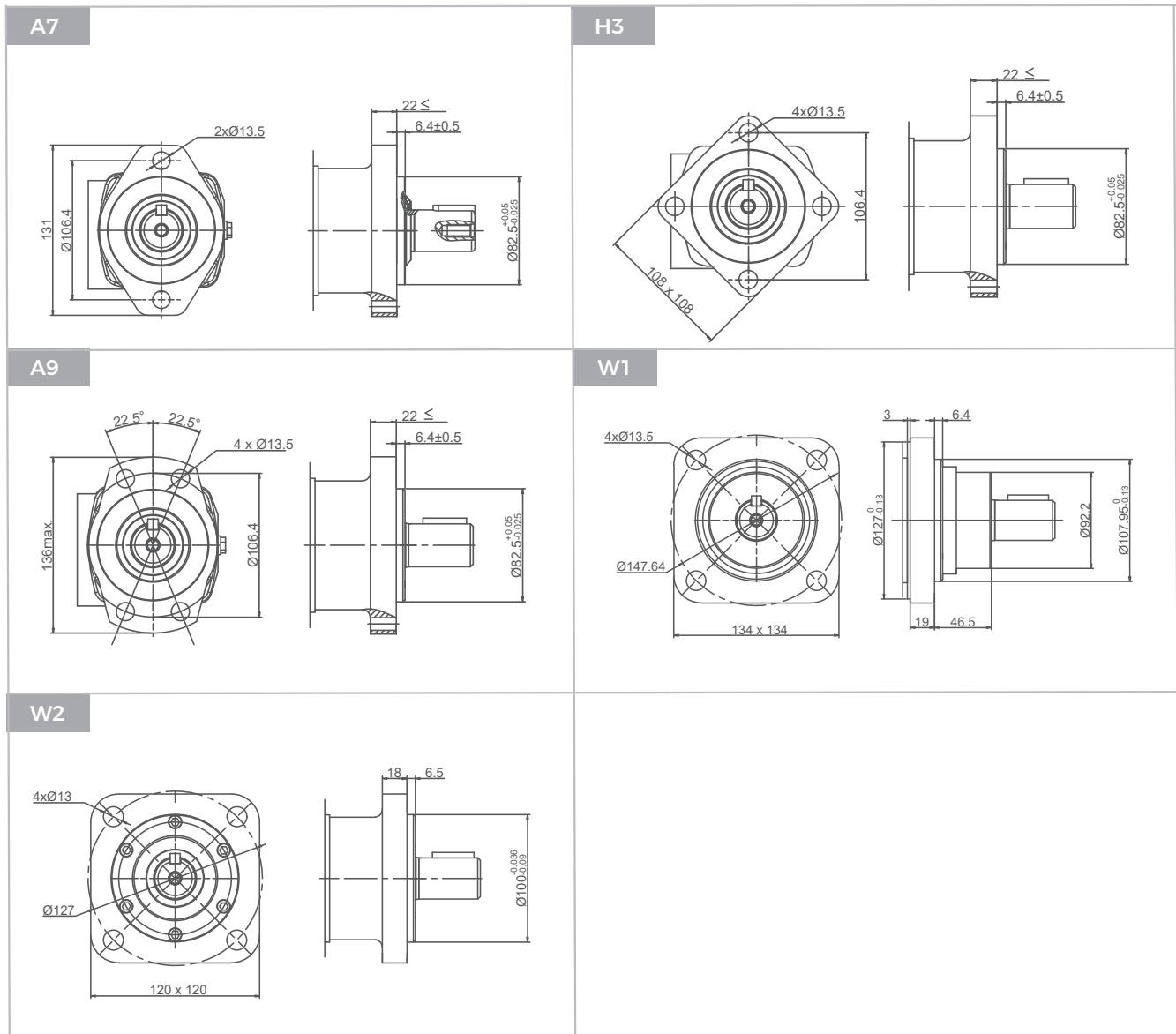

GKA Shafts Dimensions

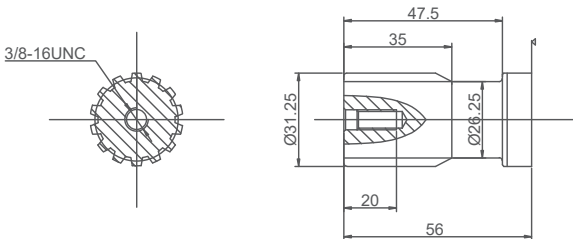
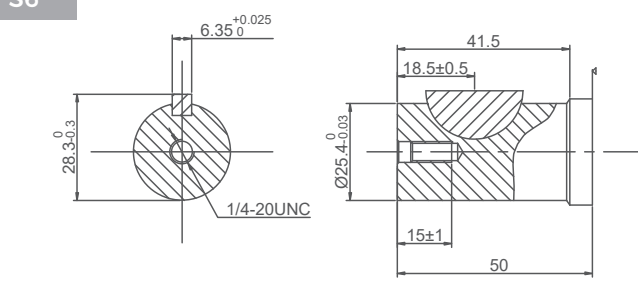
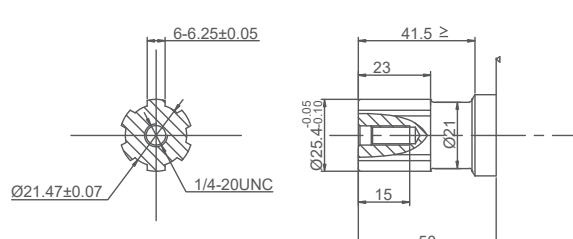
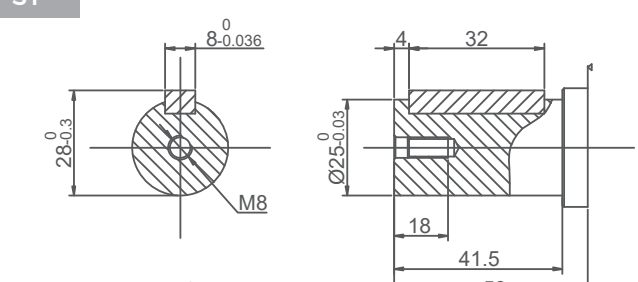
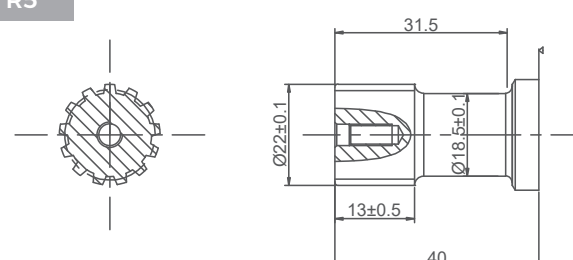
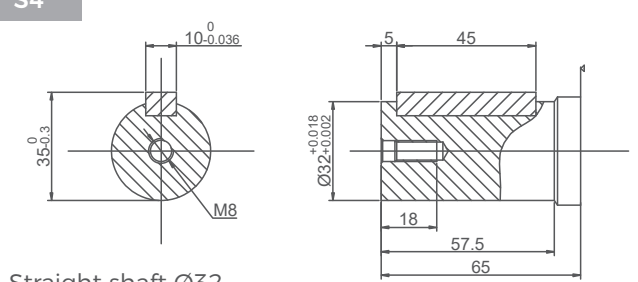
<p>R6</p>  <p>Splined shaft 14-DP 12/24</p>	<p>S6</p>  <p>Straight shaft Ø25.4 Woodruff key 25.4 x 6.35</p>
<p>R8</p>  <p>Splined shaft Ø25.4 SAE 6B</p>	<p>S1</p>  <p>Straight shaft Ø25 Parallel key 8 x 7 x 32</p>
<p>R5</p>  <p>Splined shaft 13-DP 16/32</p>	<p>S4</p>  <p>Straight shaft Ø32 Parallel key 10 x 8 x 45</p>

GKA Shafts Dimensions

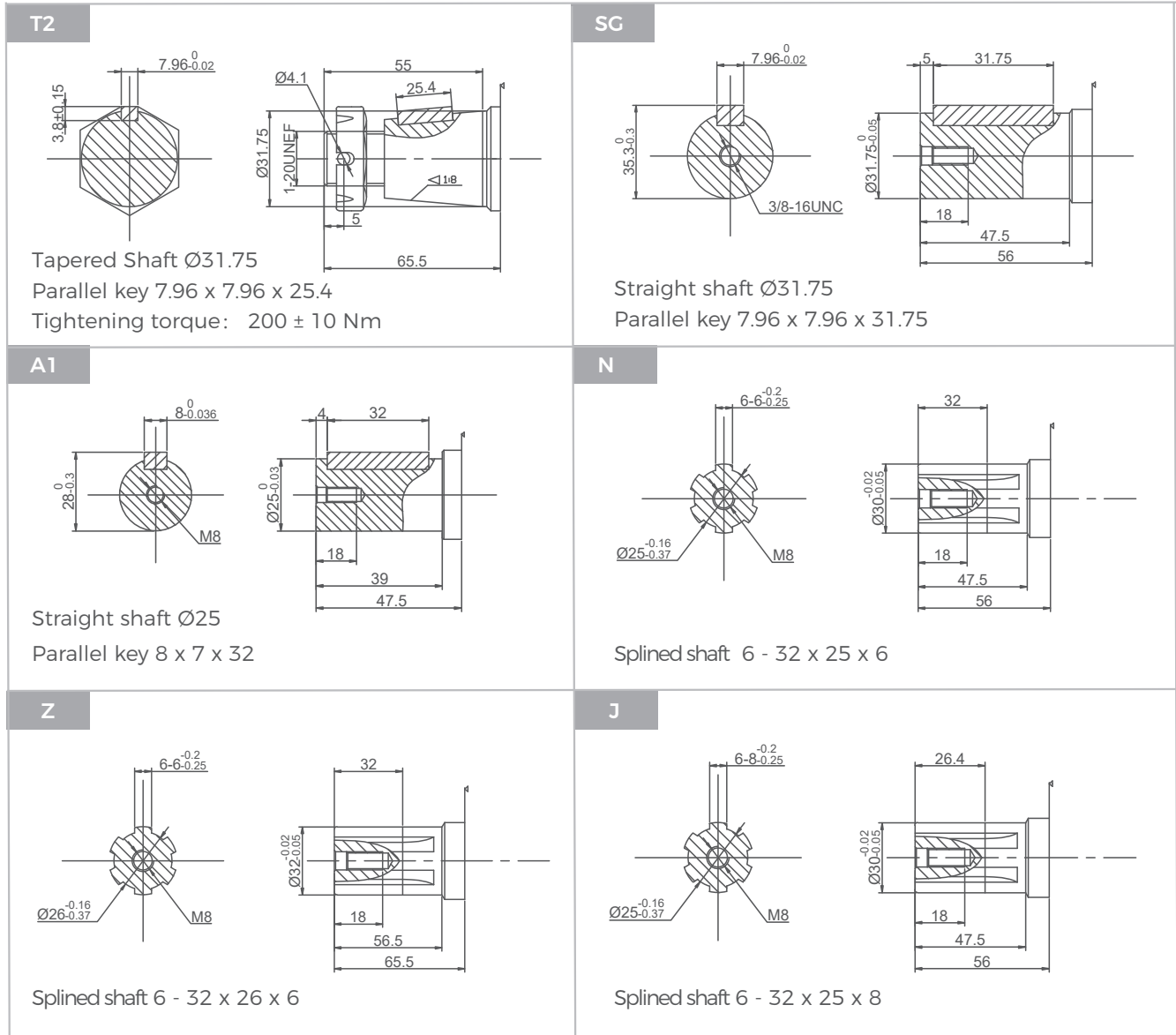

GKA Series Hydraulic Motors

Permissible shaft seal pressure

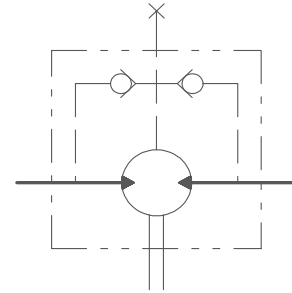
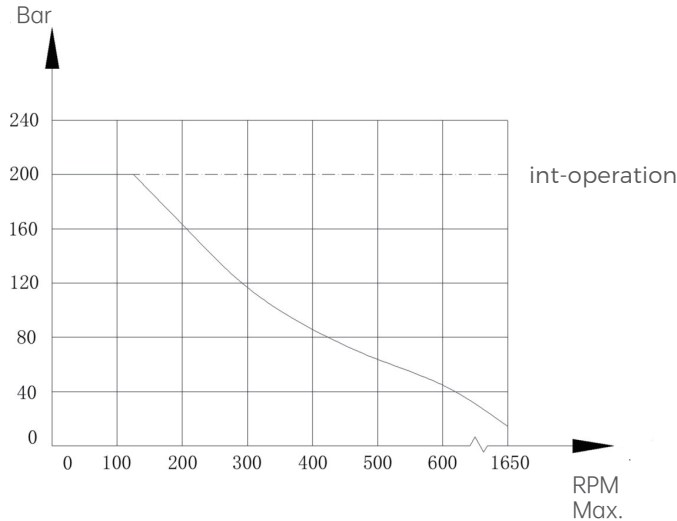

GKA with standard shaft seal check valves and without use of drain connection: The pressure on the shaft seal never exceeds the pressure in the return line.

GKA with standard shaft seal, check valves and with drain connection: The shaft seal pressure equals the pressure on the drain line.

Drain Port

In applications without drain line, output shaft seal exceeds a bit of the pressure in the return line. In applications using the drain line, the pressure of output shaft seal equals the pressure in drain line.

Standard direction of shaft rotation: Standard

When facing shaft end of motor, shaft to rotate:
Clockwise. When port A is pressurized.
Counter-clockwise when port B is pressurized.

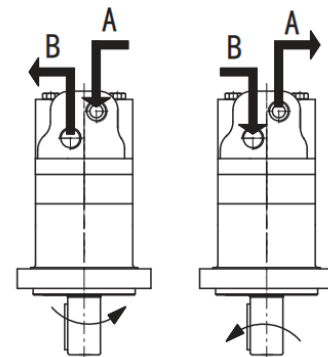

Output shaft stand radial force

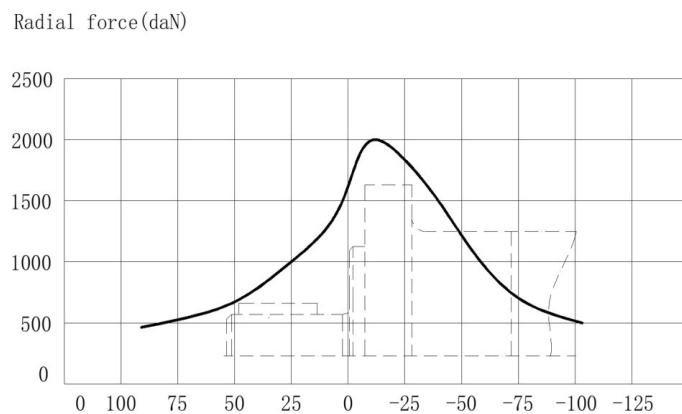

The distance between the force point and the flange surface(mm)

This radial force curve is derived from the permissible bearing life B10 load at rated torque (2,000 hours or 12x10⁶ revolutions at 150 rpm) and must be multiplied by a factor for other speeds.

GKB Series Hydraulic Motors

Options

- Flange connection
- Bearingless motor
- Speed sensing
- Straight, splined and tapered shafts
- Metric and BSPP ports
- Other special features

Applications

- Metal working machines
- Agricultural machines
- Road building machines
- Mining machines
- Food industries
- Special vehicles
- Injection molding machines
- Conveyors



General

Max. Displacement	cm ³ /rev [in ³ /rev]	625 [38.0]
Max. Speed	RPM	697
Max. Torque	daNm [lb-in]	cont.: 97,2 [8605] int.: 118,1 [10450]
Max. Pressure Drop	bar [PSI]	cont.: 205 [3000] int.: 310 [4500]
Max. Oil Flow	lpm [GPM]	150 [40]
Pressure Fluid		Mineral based- HLP (DIN 51524) or HM (ISO 6743/4)
Temperature Range	°C [°F]	-40÷140 [-40÷284]
Optimal Viscosity range	mm ² /s [SUS]	20÷75 [98÷347]
Filtration		ISO code 20/16 (Min. recommended fluid filtration of 25 microns)

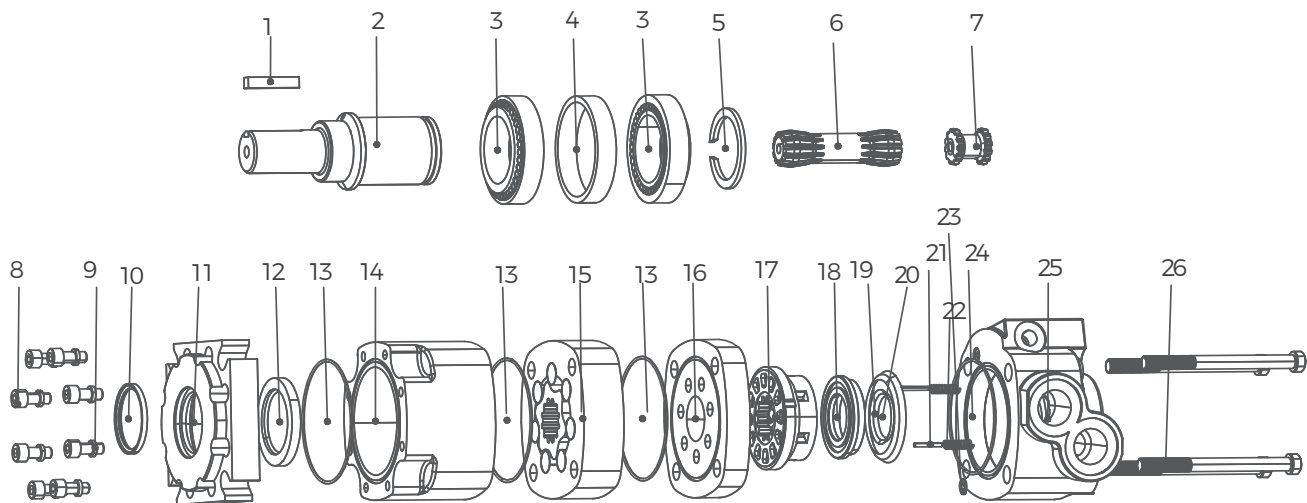

1 Flat key	6 Transmission shaft	11 Flange	16 Balance plate	21 Positioning pins
2 Output shaft	7 Coupling shaft	12 Shaft seal	17 Flow distribution plate	22 Spring
3 Tapered roller bearing	8 Bolt	13 Sealing gasket	18 Flow pressure plate	23 O-ring
4 Bearing outer retainer ring	9 Spring washer	14 Rear housing	19 Inner butterfly ring	24 O-ring
5 Washers	10 Anti-dust ring	15 Rotor and stator	20 Outer butterfly ring	25 Rear housing
				26 Screw

Specifications

Type		GKB100	GKB130	GKB160	GKB205	GKB245
Displ. cm ³ /rev [in ³ /rev]		110[6.7]	130[7.9]	160[9.9]	205[12.5]	245[15.0]
Max. Speed	Cont.	626	722	582	459	383
RPM	Int*	697	862	693	546	532
Flow	Cont.	75[20]	95[25]	95[25]	95[25]	95[25]
lpm [GPM]	Int*	95[25]	115[30]	115[30]	115[30]	130[35]
Torque	Cont.	32.2[2850]	37.6[3330]	48.5[4290]	59.9[5300]	70.5[6240]
daNm [lb - in]	Int*	47.0[4160]	55.8[4940]	70.5[6240]	80.2[7100]	84.4[7470]
Pressure Δ	Cont.	205[3000]	205[3000]	205[3000]	205[3000]	205[3000]
bar [Δ PSI]	Int*	310[4500]	310[4500]	310[4500]	310[4500]	260[3750]
	Peak**	310[4500]	310[4500]	310[4500]	310[4500]	310[4500]
Weight kg [lb]	Standard or Wheel mount	17.9[39.5]	18.1[40.0]	18.1[40.0]	18.4[40.5]	18.6[41.0]
	Bearingless	14.1[31.0]	14.1[31.0]	14.3[31.5]	14.5[32.0]	14.7[32.5]

Type		GKB280	GKB310	GKB395	GKB495	GKB625
Displ. cm ³ /rev [in ³ /rev]		280[17.1]	310[19.0]	395[24.0]	495[30.0]	625[38.0]
Max. Speed	Cont.	336	303	239	191	151
RPM	Int*	468	422	376	305	241
Flow	Cont.	95[25]	95[25]	95[25]	95[25]	95[25]
lpm [GPM]	Int*	130[35]	130[35]	150[40]	150[40]	150[40]
Torque	Cont.	75.3[6666]	85.1[7530]	93.1[8240]	94.6[8375]	97.2[8605]
daNm [lb - in]	Int*	95.7[8471]	106.4[9420]	118.3[10470]	116.9[10350]	118.1[10450]
Pressure	Cont.	205[3000]	205[3000]	190[2750]	140[2000]	115[1700]
bar [PSI]	Int*	260[3750]	260[3750]	240[3500]	170[2500]	140[200]
	Peak**	310[4500]	310[4500]	295[4250]	230[3300]	180[2600]
Weight kg [lb]	Standard or Wheel mount	19.1[42.0]	19.5[43.0]	20.4[45]	21.8[48.0]	23.1[51.0]
	Bearingless	15.2[33.5]	15.6[34.5]	16.6[36.5]	17.9[39.5]	19.3[42.5]

GKB Dimensions and Mountings

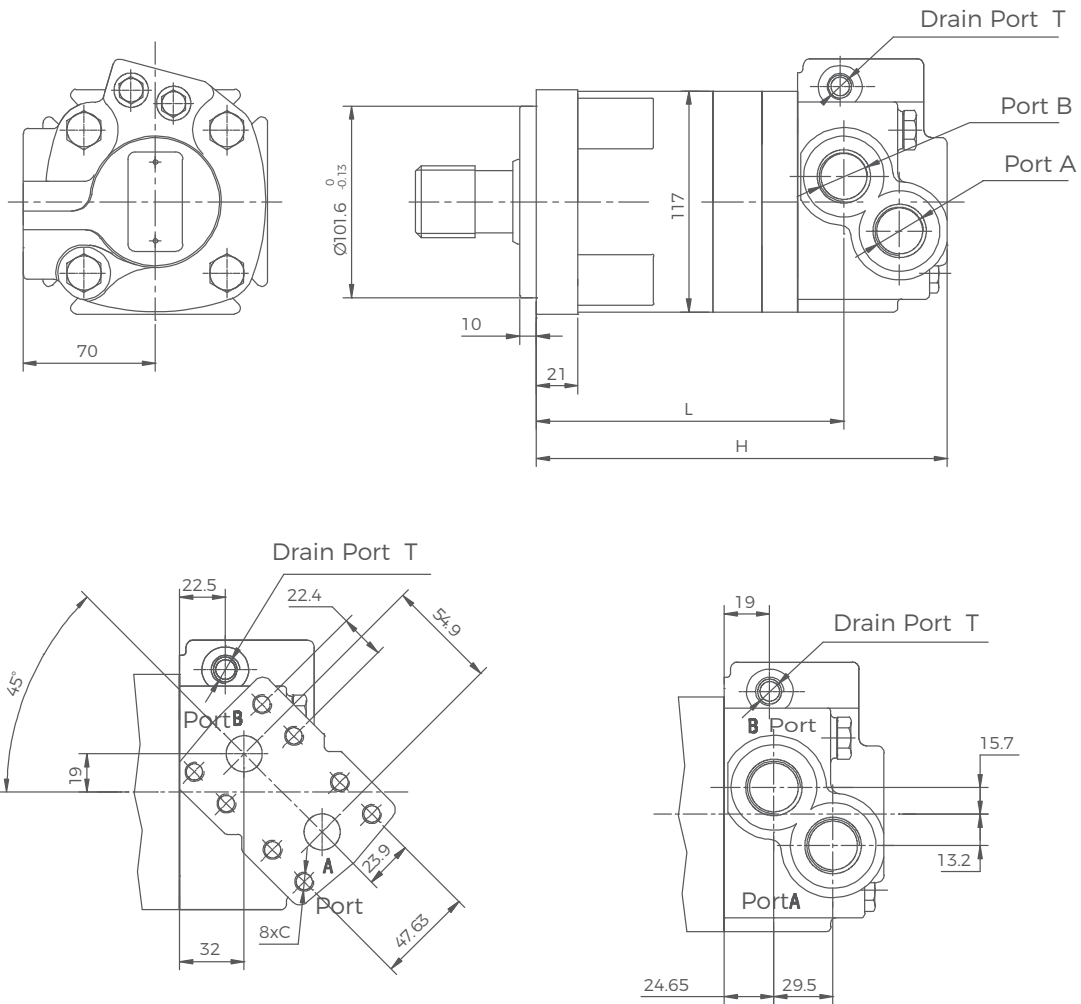

Model	1-1/16-12 or G3/4 Threaded Ports		3/4 Split Flange Oil Ports	
	H	L	H	L
GKB110	214.4	158.3	246.3	166.7
GKB130	218.4	162.3	250.4	170.8
GKB160	224.7	168.7	256.7	177.1
GKB205	233.2	177.2	265.2	185.6
GKB245	224.7	168.7	256.7	177.1
GKB310	233.2	177.2	265.2	185.6
GKB395	243.9	187.9	275.9	196.3
GKB495	256.8	200.7	288.8	209.2
GKB625	273.9	217.8	305.9	226.2

Mounting	U5 (depth)	UK (depth)	MD (depth)	UL (depth)
P(A, B)	1-1/16-12 O-ring	7/8-14 UNF O-ring	M22 x 1.5	2- $\text{Ø}19.05$
T	7/16-20 O-ring	9/16-18 UNF O-ring	M22 x 1.5	7/16-20 UNF
C	—	—	—	M10

GKB Flange Covers Dimensions

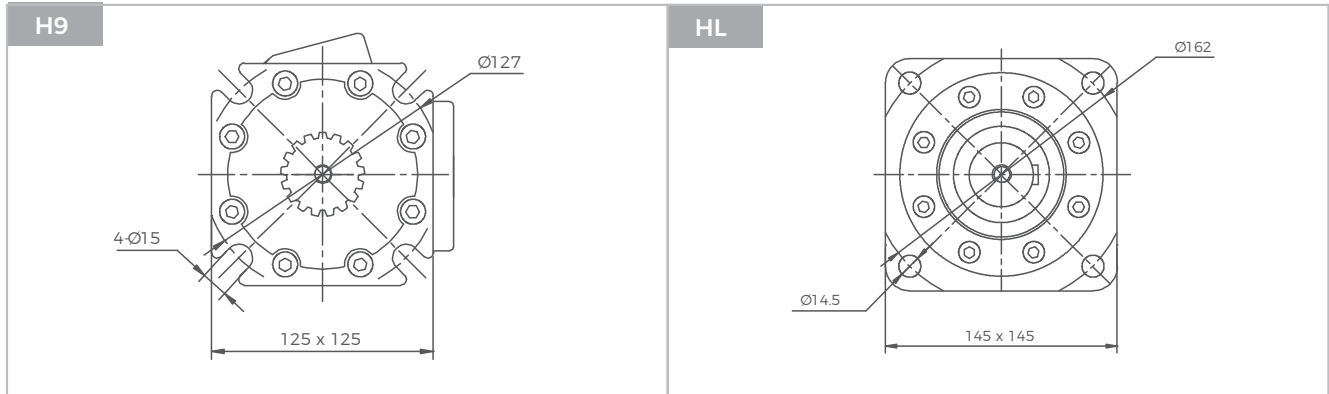

GKB Wheel Motor Dimensions and Mountings

Flange W7

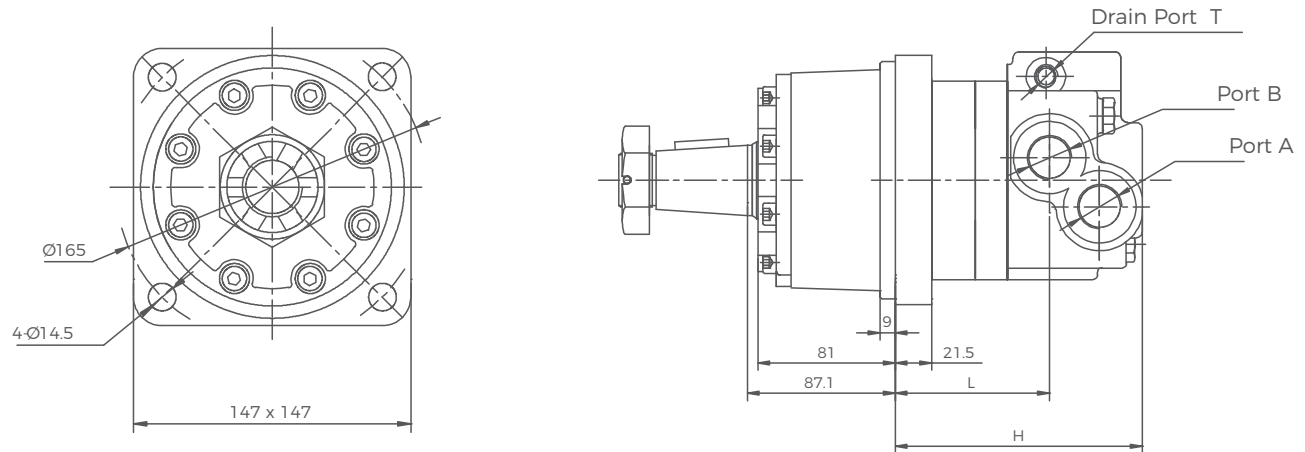

Model	1-1/16-12 or G3/4 Threaded Ports		3/4 Split Flange Oil Ports	
	H	L	H	L
GKB110	143.3	87.4	174.5	95.1
GKB130	147.3	91.5	178.5	99.1
GKB160	153.6	97.8	184.9	105.5
GKB205	162.2	106.3	193.4	114.0
GKB245	153.6	97.8	184.9	105.5
GKB310	162.2	106.3	193.4	114.0
GKB395	172.8	117.0	204.1	124.7
GKB495	185.8	129.9	217.0	137.6
GKB625	202.8	147.0	234.0	154.6

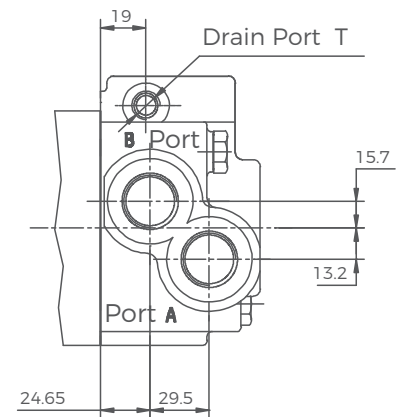

Mounting	U5 (depth)	UK (depth)	MD (depth)	UL (depth)
P(A, B)	1-1/16-12 O-ring	7/8-14 UNF O-ring	M22 x 1.5	2-Φ 19.05
T	7/16-20 O-ring	9/16-18 UNF O-ring	M22 x 1.5	7/16-20 UNF
C	—	—	—	M10

GKB Bearingless Motor Dimensions and Mountings

Flange HM

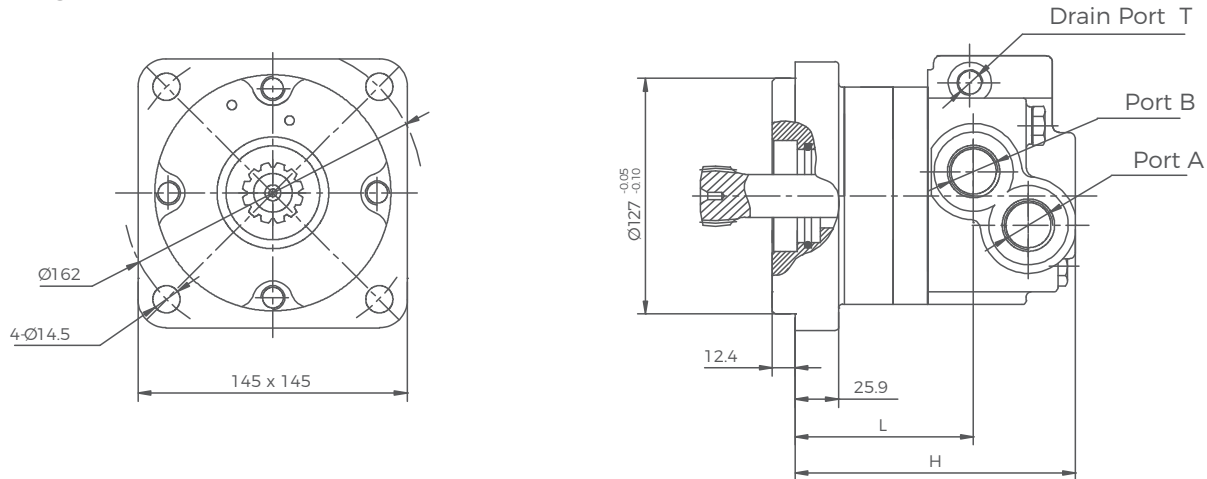

Model	1-1/16-12 or G3/4 Threaded Ports		3/4 Split Flange Oil Ports	
	H	L	H	L
GKB110	146.8	91.0	178.7	99.4
GKB130	150.8	95.1	182.8	103.5
GKB160	157.1	101.4	189.1	109.8
GKB205	165.7	109.9	197.6	118.3
GKB245	157.1	101.4	189.1	109.8
GKB310	165.7	109.9	197.6	118.3
GKB395	176.3	120.6	208.3	129.0
GKB495	189.2	133.5	221.2	141.9
GKB625	206.3	150.5	238.3	159.0

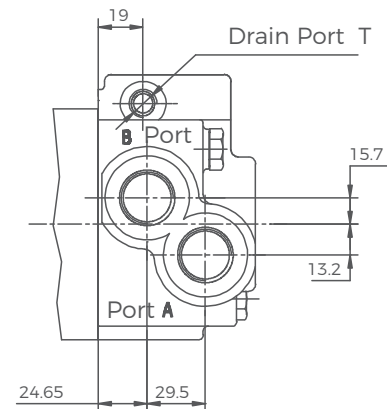

Mounting	U5 (depth)	UK (depth)	MD (depth)	UL (depth)
P(A, B)	1-1/16-12 O-ring	7/8-14 UNF O-ring	M22 x 1.5	2-Ø19.05
T	7/16-20 O-ring	9/16-18 UNF O-ring	M22 x 1.5	7/16-20 UNF
C	—	—	—	3 x 3/8-16UNC

GKB Shafts Dimensions

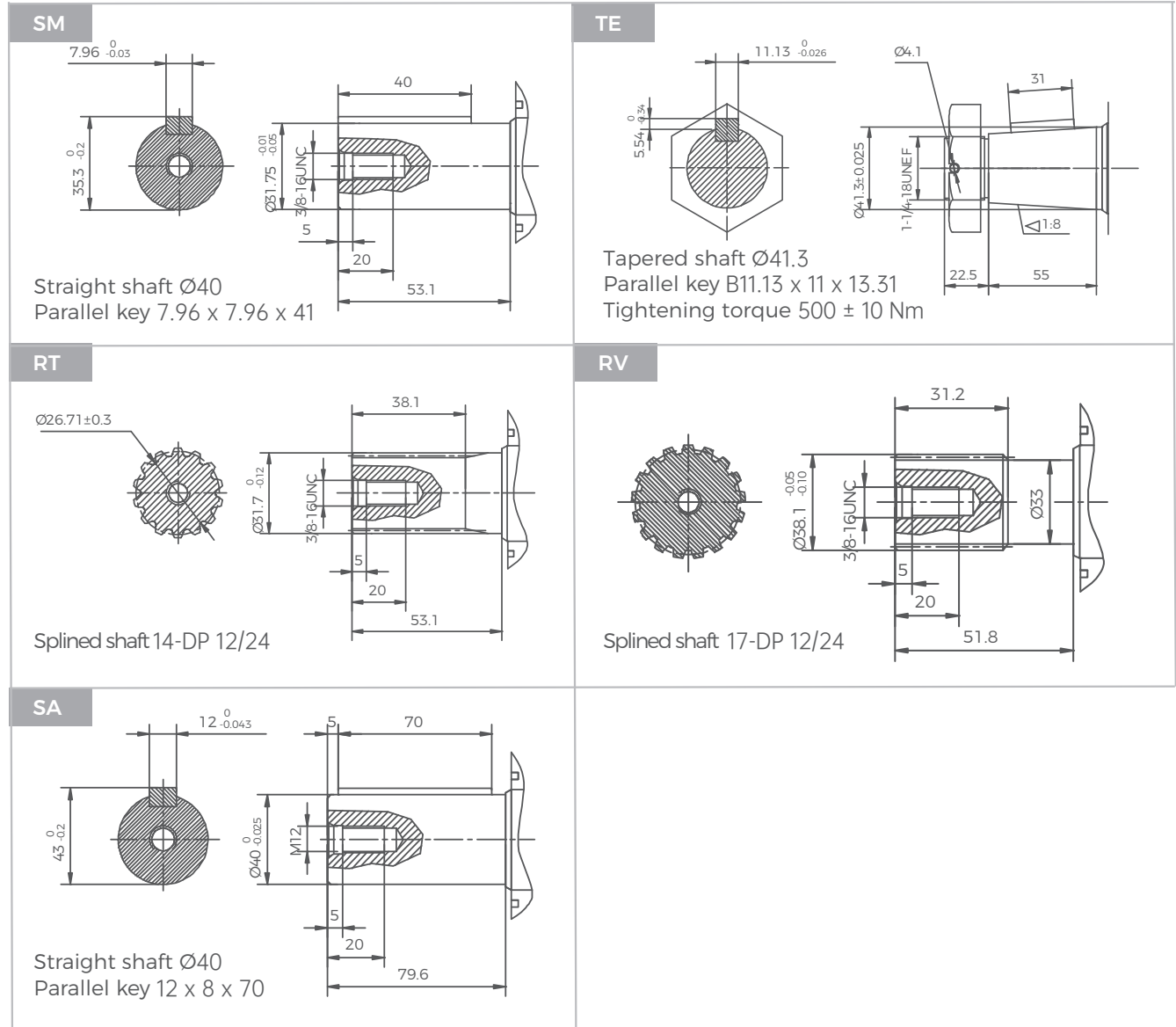

GKB Series Hydraulic Motors

Standard direction of shaft rotation: Standard

When facing shaft end of motor, shaft to rotate:
Clockwise. When port A is pressurized.
Counter-clockwise port B is pressurized.

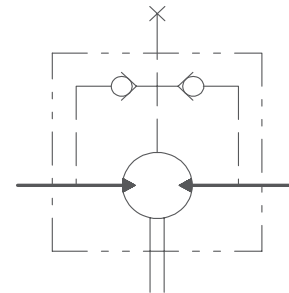
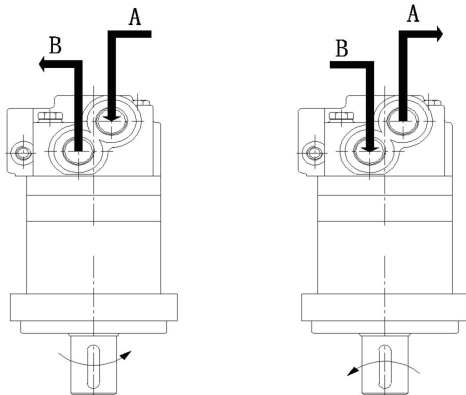

GKB with standard shaft seal check valves and without use of drain connection: The pressure on the shaft seal never exceeds the pressure in the return line.

GKB with standard shaft seal, check valves and with drain connection: The shaft seal

Output shaft stand radial force

The following curves represent the load capacity at various locations along the radial direction of the motor output shaft. The curves are based on B10 bearing life at rated output torque. (2000 hours or 12,000,000 revolutions at 100RPM). To determine the radial load at speeds other than 100 RPM, multiply the load values on the bearing curves by the factors given in the table below.

RPM	Coefficients
50	1.23
100	1.00
200	0.81
300	0.72
400	0.66
500	0.62
600	0.58
700	0.56
800	0.54

52% increase in load capacity at 3,000,000 rpm or 500 hours.

Wheel motor with tapered shaft

Radial force (daN)

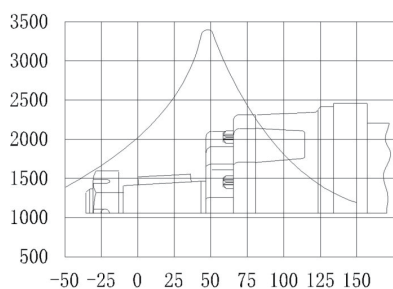

The distance between the force point and the flange surface (mm)

Standard motor with cylindrical shaft

Radial force (daN)

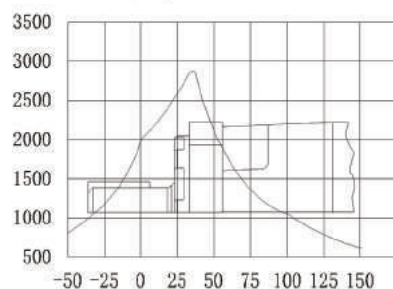

The distance between the force point and the flange surface (mm)

Standard motor with spline shaft

Radial force (daN)

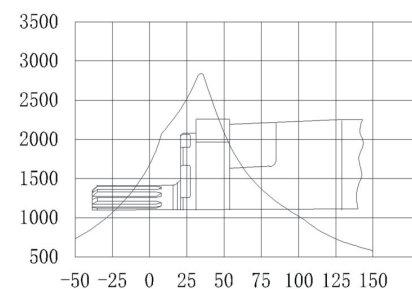

The distance between the force point and the flange surface (mm)

GKC Series Hydraulic Motors

OPTIONS

- Flange connection
- Straight, splined and tapered shaft
- Metric and BSPP ports
- Other special features

APPLICATION

- Conveyors
- Feeding machinery
- Metal working machines
- Textile machines
- Agricultural machines
- Food industries
- Mining machines



General

Max. Displacement	cm ³ /rev [in ³ /rev]	985 [60.0]
Max. Speed	RPM	866
Max. Torque	daNm [lb-in]	cont.:168,5 [14920] int.:187,5 [16580]
Max. Pressure Drop	bar [PSI]	cont.:205 [3000] int.:300 [4500]
Max. Oil Flow	lpm [GPM]	225 [60]
Pressure fluid		Mineral based- HLP (DIN 51524) or HM (ISO 6743/4)
Temperature Range	°C [°F]	-40÷140 [-40÷284]
Optimal Viscosity range	mm ² /s [SUS]	20÷75 [98÷347]
Filtration		ISO code 20/16 (Min. recommended fluid filtration of 25 microns)

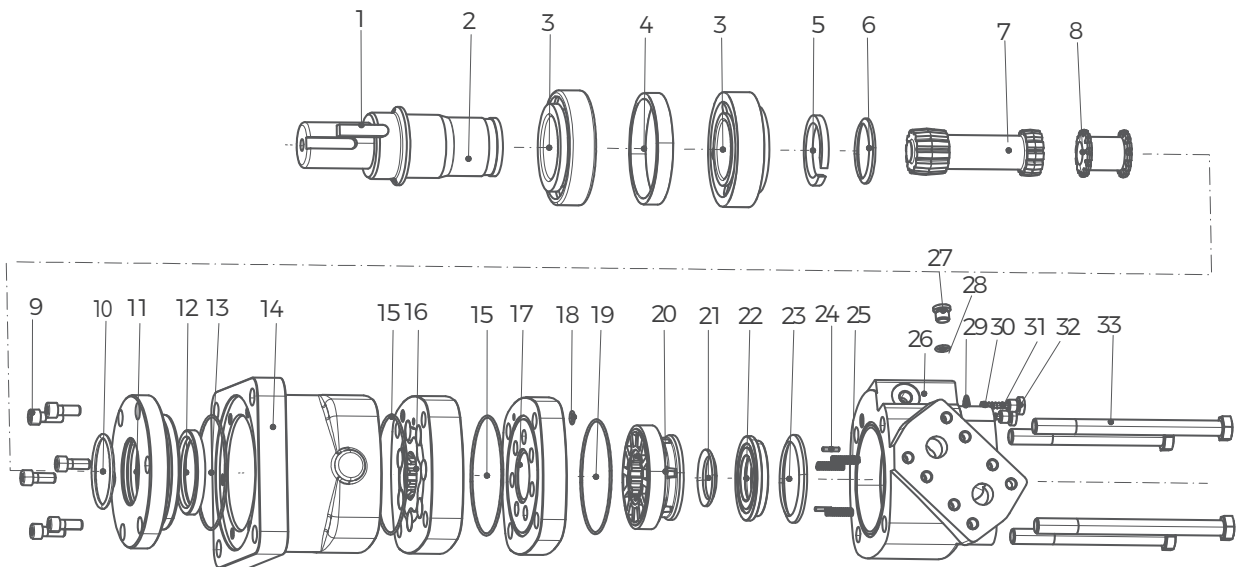

- | | | | | |
|-------------------------------|------------------|-----------------------|-------------------------------|------------------|
| 1 Paralled key | 8 Coupling shaft | 15 O-ring | 22 Distributor pressure plate | 29 Washer |
| 2 Output shaft | 9 Screw | 16 Rotor and stator | 23 Special shape ring | 30 Steel Ball |
| 3 Tapered roller bearing | 10 O-ring | 17 Balance plate | 24 Positioning pins | 31 Spring |
| 4 Bearing outer retainer ring | 11 Front cover | 18 O-ring seal | 25 Spring | 32 Hexagon plugs |
| 5 Washers | 12 Shaft seal | 19 O-ring seal | 26 Rear housing | 33 Screw |
| 6 Special shape ring | 13 O-ring | 20 Distribution plate | 27 Plug | |
| 7 Transmission shaft | 14 Housing | 21 Special shape ring | 28 O-ring | |

Specifications

Type		GKC195	GKC245	GKC310	GKC390	GKC490
Displacement cm ³ /rev [in ³ /rev]		195[11.9]	245[15.0]	310[19.0]	390[23.9]	490[30.0]
Max. Speed	Cont.	775	615	485	387	307
RPM	Int.*	866	834	698	570	454
Max. Oil Flow	Cont.	150[40]	150[40]	150[40]	150[40]	150[40]
lpm [GPM]	Int.*	170[45]	210[55]	225[60]	225[60]	225[60]
Max. Torque	Cont.	57,5[5100]	73,5[6510]	93,0[8230]	115,5[10230]	144,5[12800]
daNm [lb - in]	Int.*	86,0[7620]	110,0[9740]	135,5[11990]	163,5[14490]	188,5[16670]
Max. Inter Pressure	Cont.	205[3000]	205[3000]	205[3000]	205[3000]	205[3000]
bar [PSI]	Int.*	310[4500]	310[4500]	310[4500]	310[4500]	275[4000]
	Peak**	310[4500]	310[4500]	310[4500]	310[4500]	310[4500]
Weight, kg [lb]	Standard or Wheel mount	24,9[55.0]	25,2[55.5]	25,6[56.5]	26,3[58.0]	27,0[59.5]
	Bearingless	20,2[44.5]	20,4[45.0]	20,9[46.0]	21,5[47.5]	22,2[49.0]

Type		GKC625	GKC735	GKC805	GKC985
Displacement cm ³ /rev [in ³ /rev]		625[38.0]	735[45.0]	805[49.0]	985[60.0]
Max. Speed	Cont.	241	203	187	153
RPM	Int.*	353	303	280	230
Max. Oil Flow	Cont.	150[40]	150[40]	150[40]	150[40]
lpm [GPM]	Int.*	225[60]	225[60]	225[60]	225[60]
Max. Torque	Cont.	148,0[13100]	137,8[12192]	158,2[14004]	168,5[14920]
daNm [lb - in]	Int.*	189,8[16800]	169,9[15040]	185,0[16377]	187,5[16580]
Max. Inter Pressure	Cont.	170[2500]	140[2000]	140[2000]	140[2000]
bar [PSI]	Int.*	221[3200]	170[2500]	170[2500]	140[2000]
	Peak**	240[3500]	205[3000]	170[2500]	170[2500]
Weight, kg [lb]	Standard or Wheel mount	27,9[61.5]	28,6[63.0]	29[64.0]	30,4[67.0]
	Bearingless	23,1[51.0]	23,8[52.5]	24,3[53.5]	25,6[56.5]

GKC Dimensions and Mountings

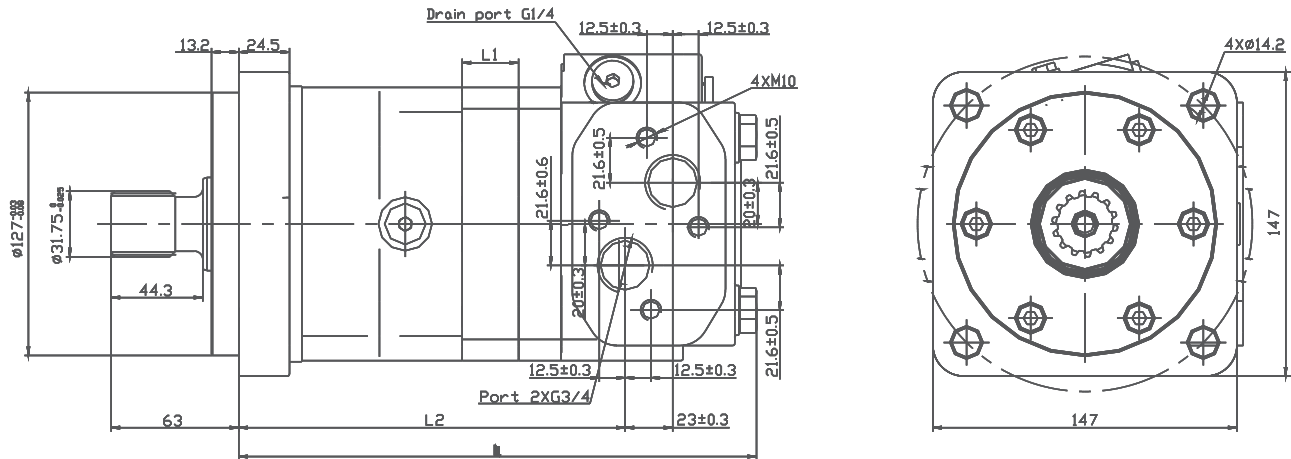

Model	L	L1	L2
GKC195	247	21.7	182
GKC245	252	27.3	187
GKC310	278	34.5	200
GKC395	287	43.4	209.5
GKC490	298	54.4	221
GKC625	313	69.1	235
GKC735	325	79.1	245
GKC805	333	88.9	255
GKC985	353	109	274.6

GKC Shafts Dimensions

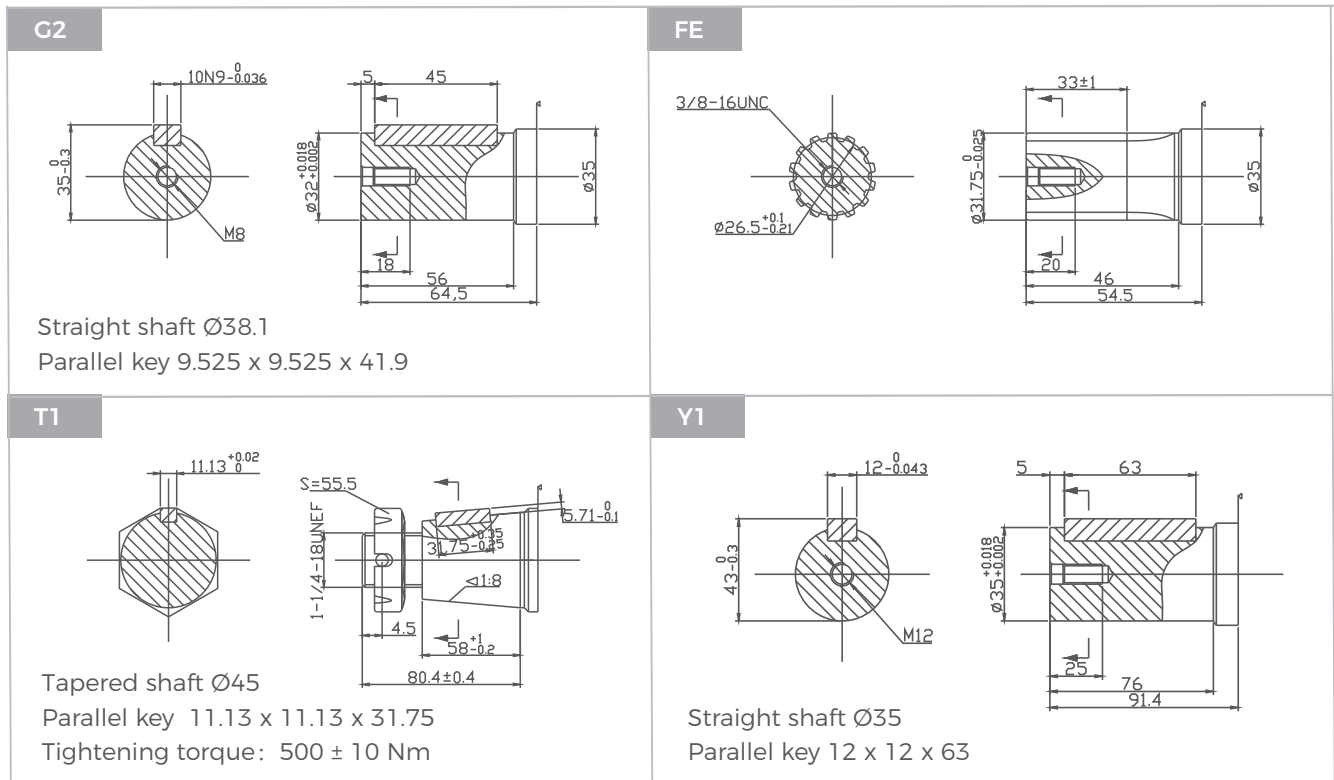

GKC Series Hydraulic Motors

Permissible shaft seal pressure

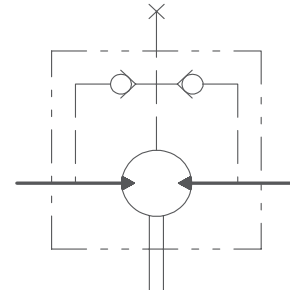
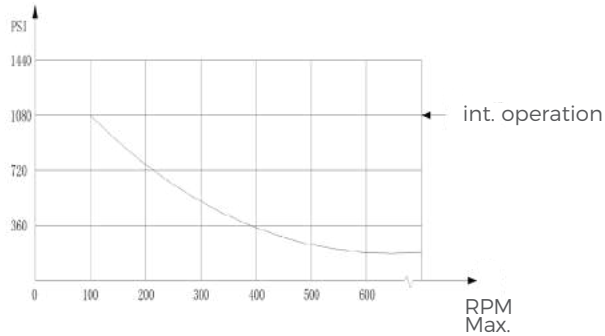

GKC with standard shaft seal check valves and without use of drain connection: The pressure on the shaft seal never exceeds the pressure in the return line.

GKC with standard shaft seal, check valves and with drain connection: The shaft seal pressure equals the pressure on the drain line.

Drain Port

In applications without a motor drain line, the pressure exerted on the shaft seal is marginally in excess of the return line pressure. When the Drain line is used, the pressure exerted on the shaft seal is equal to the return line pressure.

Standard direction of shaft rotation: Standard

When facing the shaft end of the motor, the shaft rotates: clockwise when port "A" is pressurized.

When port "B" is pressurized, it rotates counterclockwise.

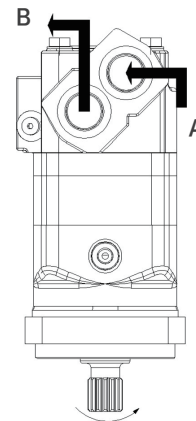

GKC for CC Mounting Radial forces

Radial forces-(daN)

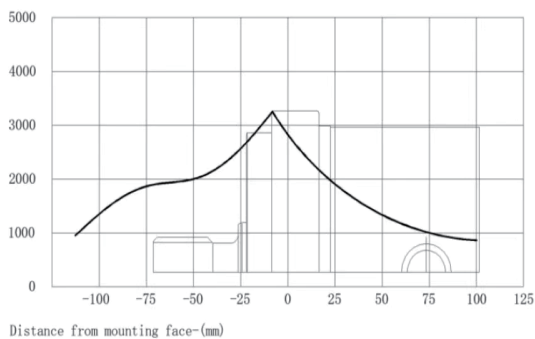

The bearing curve represents allowable bearing loads for an B10 bearing life(2000 hours or 12x10⁶ revolutions at 100rpm) at rated output torque. Other speed load multiply a load values. The maximum load curve is defined by bearing static load capacity.

This curve should not be exceeded at any time including shock loads.

GWD Series Hydraulic Motors

Options

- Rotor flow distribution, geroler type
- Geroler type
- Motor with needle bearing
- Align the ports on the side
- Straight, splined and tapered shafts
- High pressure seal
- Metric, SAE and BSPP ports

Applications

- Aerial work platform
- Material handling and lifting machines
- Agricultural machines
- Marine machines
- Road machines
- Garden machines
- Lawn and turf machines







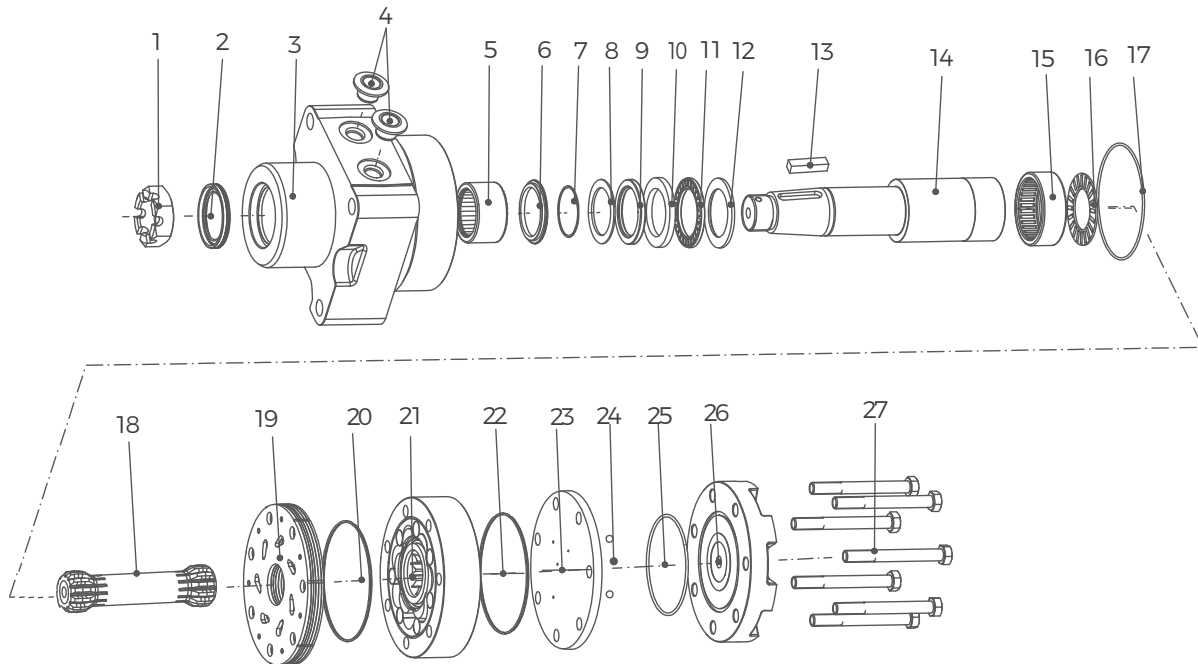







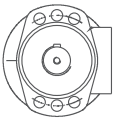



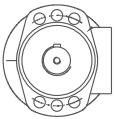

General

Max. Displacement	cm ³ /rev [in ³ /rev]	748[45.6]
Max. Speed	RPM	490
Max. Torque	daNm [lb-in]	cont.: 106.2[9400] int.: 123.7[10950]
Max. Pressure Drop	bar [PSI]	cont.: 205 [3000] int.: 300 [4500]
Max. Oil Flow	lpm [GPM]	276[72.9]
Pressure fluid		Mineral based- HLP (DIN 51524) or HM (ISO 6743/4)
Temperature Range	°C [°F]	-40÷140 [-40÷284]
Optimal Viscosity range	mm ² /s [SUS]	20÷75 [98÷347]
Filtration		ISO code 20/16 (Min. recommended fluid filtration of 25 microns)

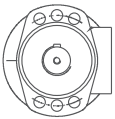

- | | | | | |
|-------------------------|---------------------|-------------------------------|-----------------------|---------------|
| 1 Castle nut | 7 O-ring | 13 Flat key | 19 Distribution plate | 26 Rear cover |
| 2 Shaft seal | 8 Washer | 14 Output shaft | 20 Special shape ring | 27 Screw |
| 3 Housing | 9 shaft seal | 15 Rear needle roller bearing | 22 Special shape ring | |
| 4 Oil port plug cap | 10 Bearing retainer | 16 Flat bearing | 23 Balance plate | |
| 5 Needle roller bearing | 11 Flat bearing | 17 O-ring | 24 Steel ball | |
| 6 Bearing | 12 Bearing retainer | 18 Transmission shaft | 25 O-ring | |

Ordering Code

GWD SERIES		DISP	FLANGE		SHAFT	PORTS		ROTATION	PAINT	FUNCTION														
CODE	DISP	CODE	FLANGE	CODE	SHAFT	CODE	PORTS	CODE	PAINT	CODE	FUNCTION													
120	121cm ³ /rev	W4	Wheel Ø147.6 4- Ø13.1 rear pilot Ø128.5×7	SH	UD	9/16-18UNF	A	No paint	A	Standard														
160	162cm ³ /rev										SL	UF	7/8-14UNF	B	Blue	F	Free running							
200	204cm ³ /rev																		TB	GC	G1/2	C	Black	V
230	232cm ³ /rev																							
260	261cm ³ /rev			RQ																				
300	300cm ³ /rev		<p>6- Ø13.5 SAE Ø106.4 pilot Ø82.5×2.8</p>																					
350	348cm ³ /rev	<p>Ø147.6 square 4- Ø13.5 pilot Ø82.5×2.8</p>																						
375	363cm ³ /rev																							
470	465cm ³ /rev																							
540	536cm ³ /rev																							
620	631cm ³ /rev																							
750	748cm ³ /rev																							
																								
																								
																								

Specifications

Type		GWD120	GWD160	GWD200	GWD230	GWD260	GWD260
Disp. cm ³ /rev.		121	162	204	232	261	261
Max. Speed	Cont	360	370	300	260	260	260
RPM	Int.	490	470	370	320	350	350
Max. Flow	Cont	45	61	68	68	76	76
LPM	Int.	61	76	83	83	91	91
Max. Torque	Cont	327	475	542	611	712	712
Nm	Int.	383	542	633	712	791	791
Max. Pressure Drop	Cont	207	207	207	207	207	207
bar	Int.	241	241	241	241	241	241
	Peak	276	276	276	276	276	276
Max. No-load Pressure	bar	8	10	10	10	10	10
Min Operating Nm	Drop Cont	235	342	390	440	513	513
Torque At Max. Pres.	Drop Int.	280	396	462	520	577	577
Weight kg	GWD	13.3	13.3	13.7	13.8	14.1	14.1

Type		GWD350	GWD375	GWD470	GWD540	GWD620	GWD750
Disp. cm ³ /rev.	cm ³ /rev.	348	363	465	536	631	748
Max. Speed	Cont	220	200	160	140	120	100
RPM	Int.	270	250	200	170	150	130
Max. Flow	Cont	76	76	76	76	76	76
LPM	Int.	95	91	91	91	91	91
Max. Torque	Cont	921	1006	1096	983	1014	1062
Nm	Int.	1045	1158	1184	1243	1291	1237
Max. Pressure Drop	Cont	207	207	172	138	121	103
bar	Int.	241	241	189	173	155	121
	Peak	276	276	207	207	173	138
Max. No-load Pressure	bar	10	10	10	12	12	12
Min Operating Nm	Drop Cont	663	724	822	737	761	797
Torque At Max. Pres.	Drop Int.	763	845	900	945	981	940
Weight kg	GWD	15.5	15	15.5	16.1	16.8	17.5

GWD Dimensions and Mountings

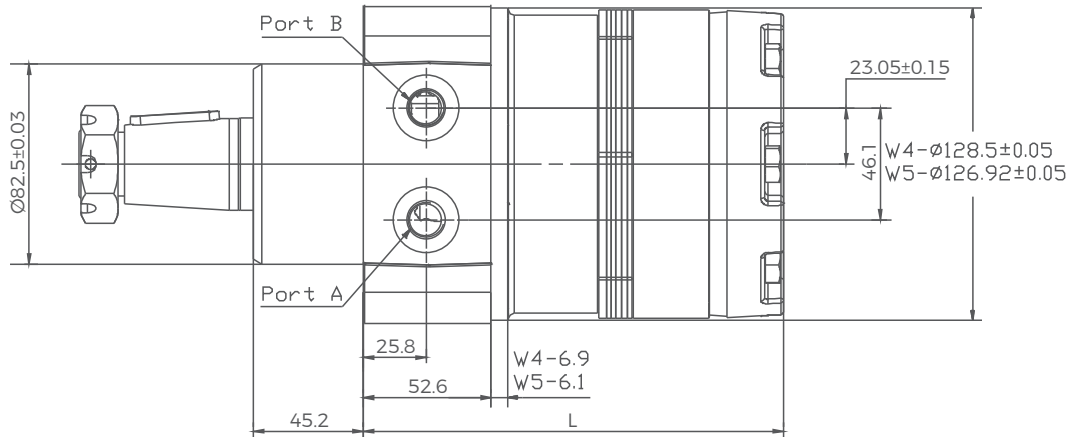

Model	L	Weight
	mm[In]	kg[lb]
GWD120	156[6.14]	13.3[29.4]
GWD160	156[6.14]	13.3[29.4]
GWD200	159[6.26]	13.7[30.2]
GWD230	162[6.38]	13.8[30.4]
GWD260	165[6.50]	14.1[31.0]
GWD300	168[6.61]	14.4[31.8]
GWD350	172[7.17]	15.5[29.4]
GWD375	174[6.85]	15.0[33.0]
GWD470	182[7.17]	15.5[34.2]
GWD540	188[7.40]	16.1[35.4]
GWD620	196[7.72]	16.8[36.9]
GWD750	206[8.11]	17.5[38.5]

GWD Flange Covers Dimensions

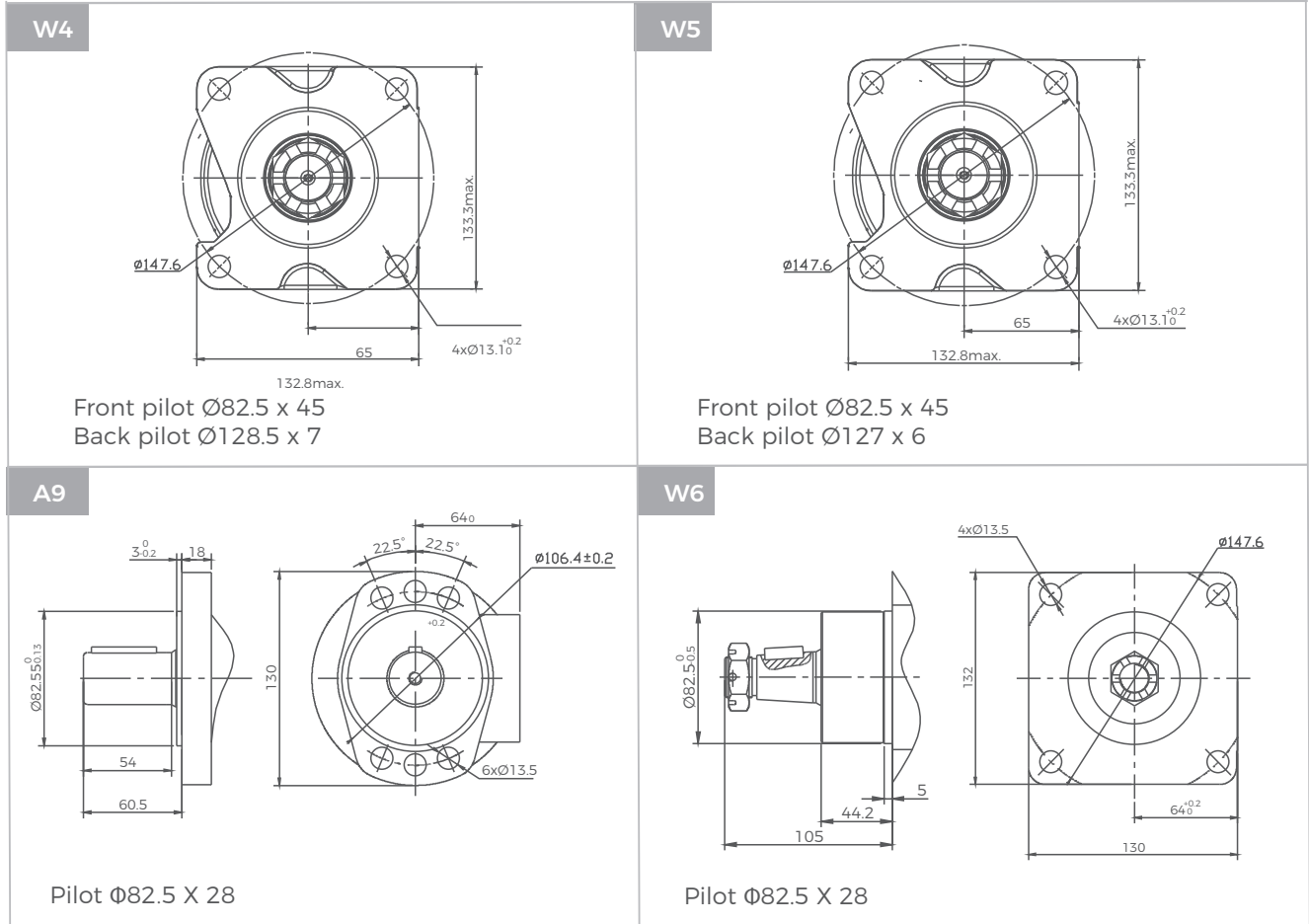

GWD Shafts Dimensions

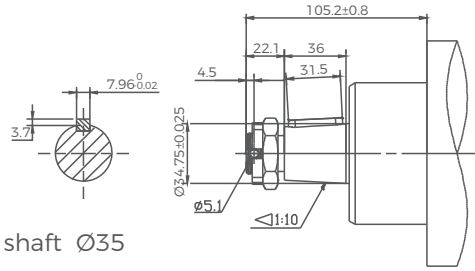
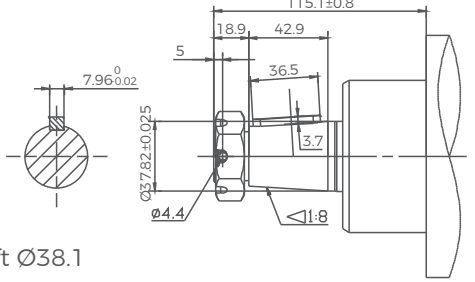
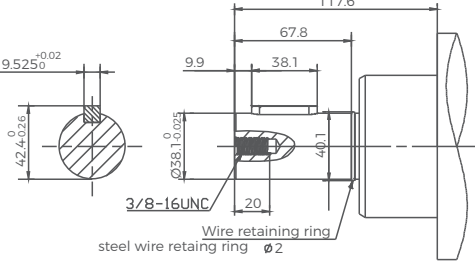
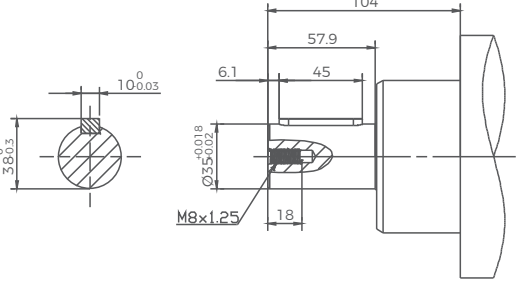
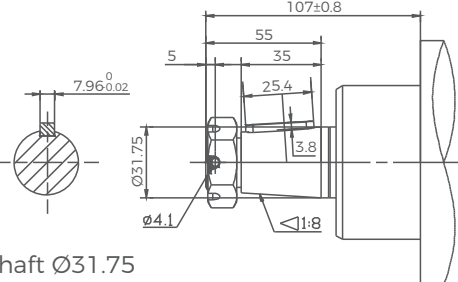
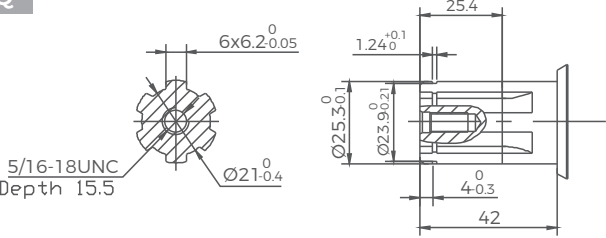
<p>TB</p>  <p>Tapered shaft $\varnothing 35$ Parallel key 7.96 x 7 x 31.5 Tightening torque: 325 Nm</p>	<p>TA</p>  <p>Tapered shaft $\varnothing 38.1$ Parallel key 7.96 x 7 x 36.5 Tightening torque: 410-540 Nm</p>
<p>SL</p>  <p>Straight shaft $\varnothing 38.1$ Parallel key 9.5 x 9.5 x 38.1</p>	<p>SH</p>  <p>Straight shaft $\varnothing 35$ Parallel key 10 x 8 x 45</p>
<p>T2</p>  <p>Tapered shaft $\varnothing 31.75$ Parallel key 7.96 x 7.96 x 25.4 Tightening torque: 200 ± 10 Nm</p>	<p>RQ</p>  <p>Splined shaft 6-25.3 x 21 x 6.2</p>

GWD Series Hydraulic Motors

Shaft Rotation Direction: Standard

When looking at the shaft end of motor, shaft will rotate:

-Clockwise.

When port B is pressurized.

-Counter-clockwise when port A is pressurized.

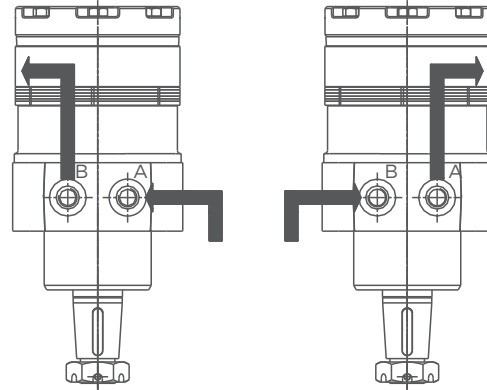
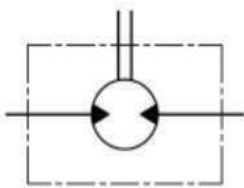

W4 & W5 Wheel Mounts

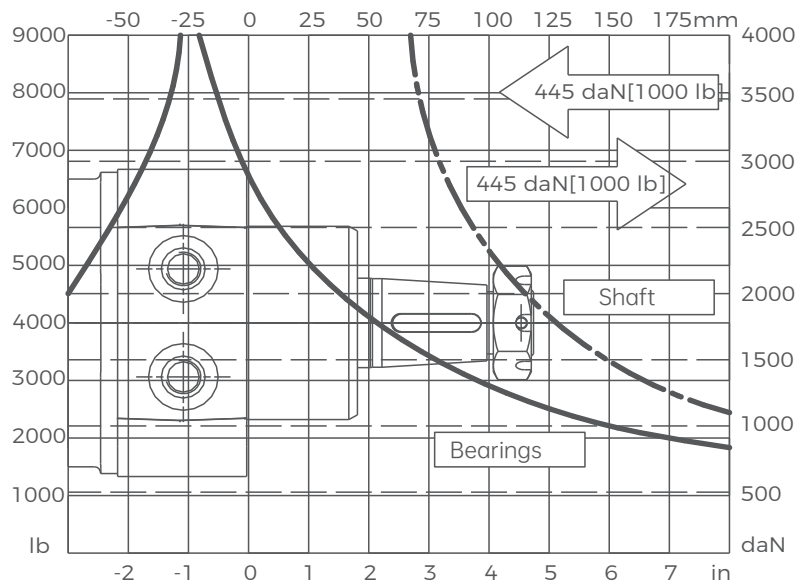

GBD Series Hydraulic Motor Brakes

Options

- Double heavy-duty roller bearings
- Double release ports
- Wet braking, spring loaded
- Smaller axial installation size
- Low noise, long service life

Applications

- Aerial work platform
- Wheel drive
- Swing drive
- Transmission



General

Specifications		GBD10	GBD15
Min. static torque	Nm	1150	1500
Brake release pressure	MPa	2.8	2.8
Max. release pressure	MPa	27.6	27.6
Min. oil released by brake	cm ³	11.5	11.5
Max. speed	rpm	250	250
Brake chamber oil volume	cm ³	100-120	100-120
Max. working oil temperature	°C	82	82
Weight	Kg	18	20

GBD Dimensions and Mountings

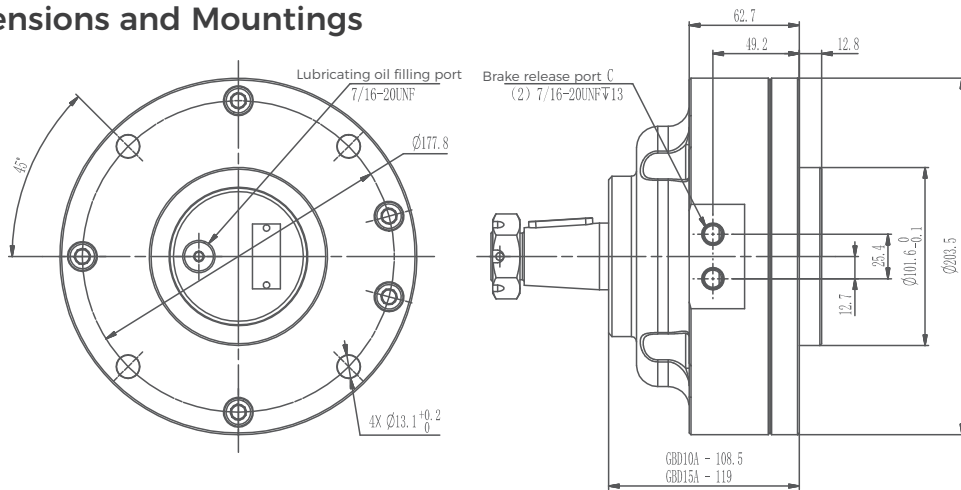

GBD Shaft Dimension

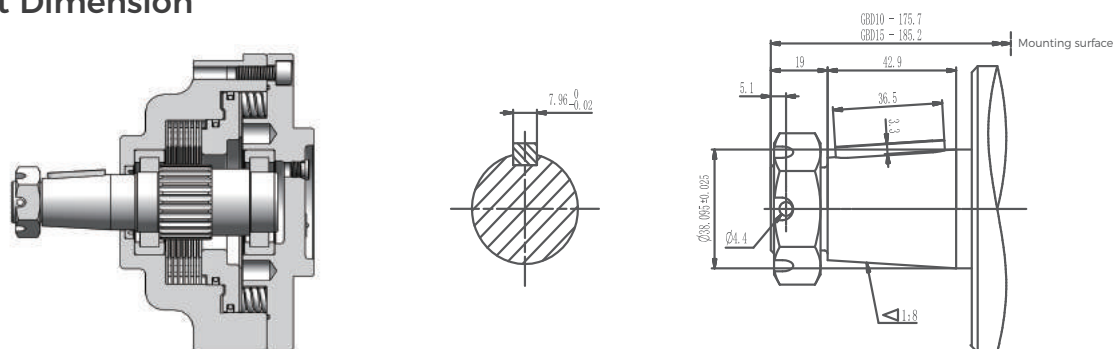

Ordering Code

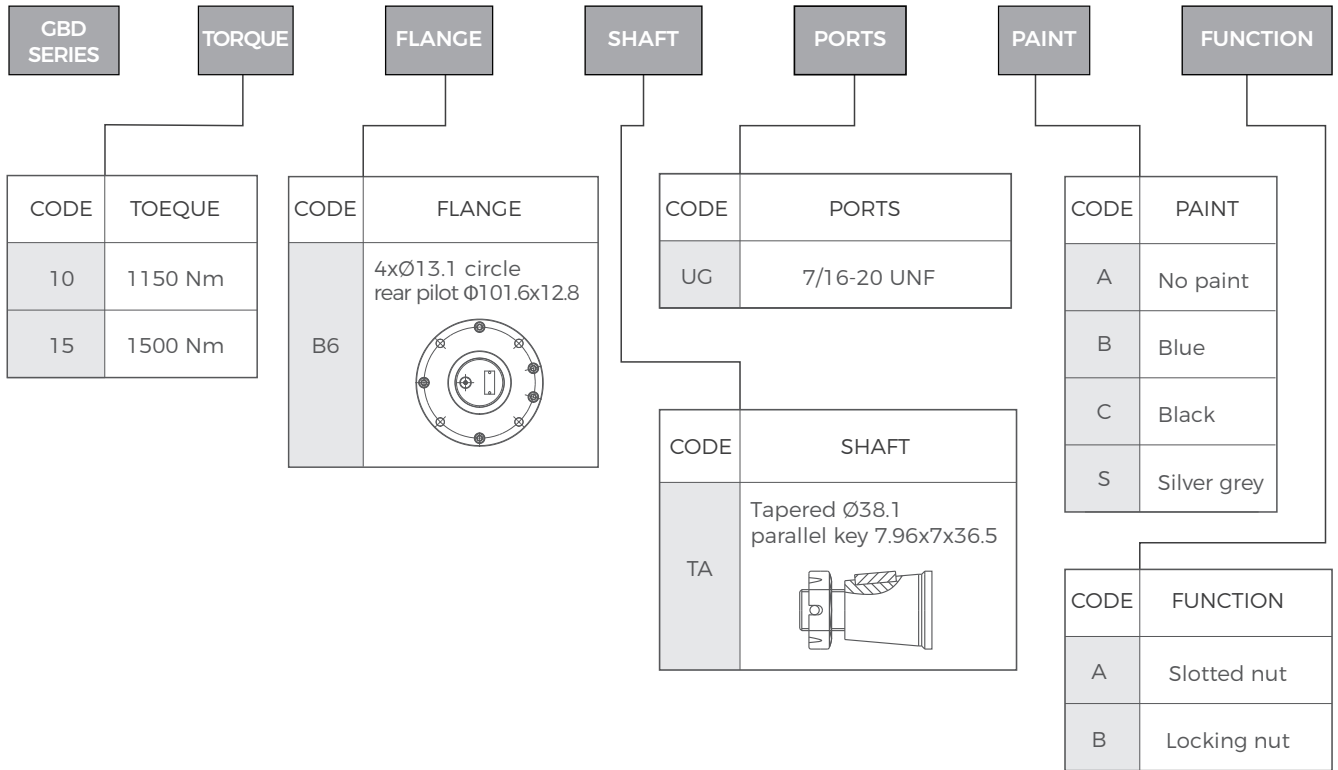

GBD Series Hydraulic Motor Brakes

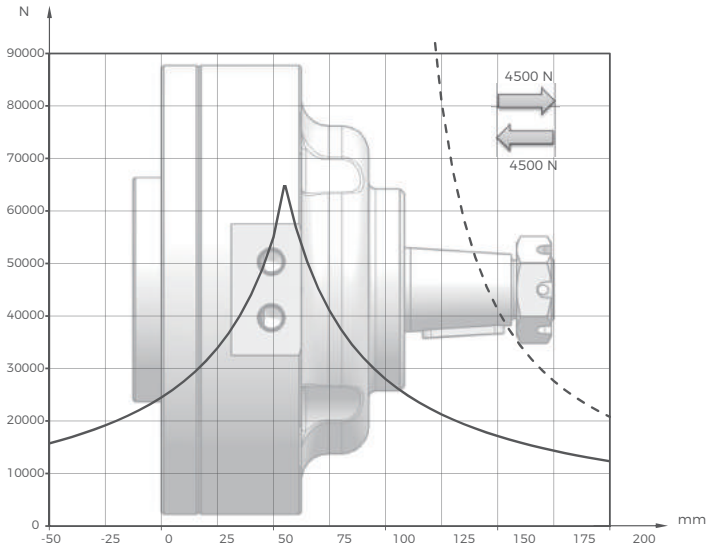

As shown in the figure, when the axial load is 0N, the radial allowable load of the output shaft is related to the distance between the mounting surface of the flange and the point where the load is applied. The solid line shows the allowable bearing radial load. Denotes the use of hydraulic oil containing anti-wear additives, and the curve is established on the basis of continuous output torque cut, motor speed of 100rpm, bearing L10 service life of 2000 hours. The dashed line shows the maximum radial load on the shaft. If the shaft extension load exceeds this value, the motor will be damaged.



Shanghai Guorui Hydraulic Technology Co., Ltd

Add. Room 2201-2202, 1717 North Sichuan Road,
Hongkou Shanghai, China
P.C. 200080
Tel. +86-21-6218 3268
Mail. info@grhcn.com

Add. 666 West Shuanghu Road, Hi-tech Zone,
Jianhu Yancheng, Jiangsu, China
P.C. 224700
Tel. +86 0515-86316688 +86 400 188 1986
Mail. info@grhpro.com

