

Technical Information

# Hydraulic Gear Pumps

0PF / 1PF / 1.5PF / 2PF / 2.5PF / 2.8PF / 3PF / 3.5PF / 4PF





## **GUORUI HYDRAULICS**

Keep the concept seeking excellence, GRH try our best to create more value for you with products and service.

# Guorui Hydraulics

## About GRH

GRH was established in 1986, focusing on providing customers with quality hydraulic components and solutions to hydraulic system in the applications of engineering machinery, mobile industries, agricultural machinery, aviation, mining, and other fields. Main products include gear pump, gear motor, flow divider, orbital motor, load sensing proportional valve, monoblock valve, sectional valve, manifold assembly and hydraulic power unit as well.

## Long-term development strategy

Reducing emissions by new energy is one of GRH's long-term strategies. GRH will be providing innovative technologies, products, and services for the global development of new energy, moving towards a century development strategy, and writing a century-new chapter in the hydraulic field.



### Innovation leads the future

Through a few decades of development, GRH has built an intelligent manufacturing factory, gathering international R&D talents, accumulating rich R&D and manufacturing experience, possessing independent intellectual property rights, continuously providing customers with new products and technologies, and creating value for all of the customers.

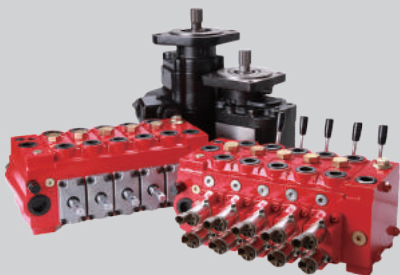



## Contents

### Aluminum Single Pumps

<b>0</b>	Ordering Code	13
	0PF	14-18
<b>1</b>	Ordering Code	19
	1PF	20-22
	1HPF	23
	1APF	24
	1QEPF	25
	1QCPF	26
<b>1.5</b>	Ordering Code	27
	1.5PF	28
<b>2</b>	Ordering Code	29
	2PF	30
	2ABPF	31-36
	2LPF	37
	2APF	38-40
<b>2.5</b>	Ordering Code	41
	2.5APF	42
	2.5CPF	43
	2.5QPF	44
<b>2.8</b>	Ordering Code	45
	2.8APF	46-47
<b>3</b>	Ordering Code	48
	3APF	49-51
	3BPF	51
<b>OM</b>	OM08	53
	OM08-3	53
	OM401	54
	OM601	54
	OM701	55
	OM702	55
	OM14	56
<b>2CP</b>	2CP18	57-58
<b>2CB-E</b>	2CB-E**/** HI/LO	59-60
<b>PTO</b>	PTO	61

## Aluminum Multiple Pumps

<b>1<sup>+</sup></b>	Ordering Code	62
	1DPF	63-64
<b>1.5<sup>+</sup></b>	1.5DPF	64
<b>2<sup>+</sup></b>	2/1DPF	65
	2ADPF	66-68
	2ABDPF	69
	2ATPF	70-71
	2AFPF	72
<b>3<sup>+</sup></b>	3/2ADPF	73
	3ADPF	74
	3ATPF	75
<b>A</b>	Application Guide of Multiple Pumps	76-83

## Cast Iron Pumps

<b>1</b>	Ordering Code	84
	1EPF	85
<b>2</b>	2YBDPF	86
<b>2.5</b>	2.5YPF	87
	2.5EPF	88
<b>3</b>	3CPF	89
<b>3.5</b>	3.5EPF	90
	3.5APF	91-92
<b>4</b>	4PF	93
<b>X</b>	XTYBA	94
<b>D</b>	C101/C102 G101/G102 Dump Pumps	95
<b>H</b>	HGP	96
<b>C</b>	Cat Pumps	97-107

## Appendix

Inlet/Outlet Combination	108
Oblate Type Shafts	109
Flat Keyed Type Shafts	110
Taper Key Type Shafts	111
SAE and Metric Involute Spline Type Shafts	112-113
DIN Spline Type Shafts	113
Front Covers	114-118

## Introduction of Guorui External Gear Pumps

External gear pumps from Guorui Hydraulics have a floating bushing feature with automatic axial clearance compensation. The bushings are made with special abrasion resistant material providing improved service life. Precisely machined gears ensure our units provide excellent low noise characteristics. Our cold extrusion pump bodies can endure pressures above 30Mpa. High strength cast iron front and rear covers also enhance our reliability. Our units are widely used in the industrial mobile marine and aerospace industries.

## Guorui Hydraulic Gear Pump Characteristics

- Guorui external gear pumps are produced in 9 different series (0P, 1P, 1.5P, 2P, 2.5P, 2.8P, 3P, 3.5P, 4P) and in each group different displacements are obtained by changing the gears width, refer to performance curves (on page 9 to page 12).
- Pressure: Guorui offers three pressure ratings E, F and G, please refer to charts.
- Efficiencies: volumetric efficiency up to 98%, mechanical efficiency up to 88%.
- Mountings: flanges, shaft ends and ports.
- Seals: viton, buna and EPR seals is available.
- Integration: all pumps can be ordered with relief valve and check valve.

Rate E

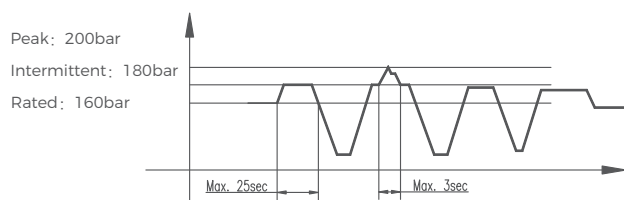

Rate F

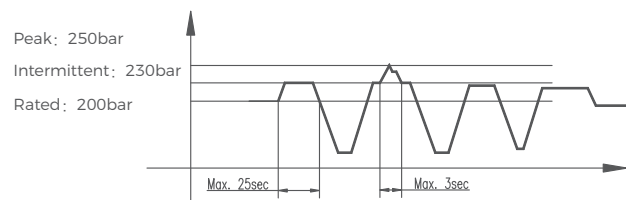

Rate G

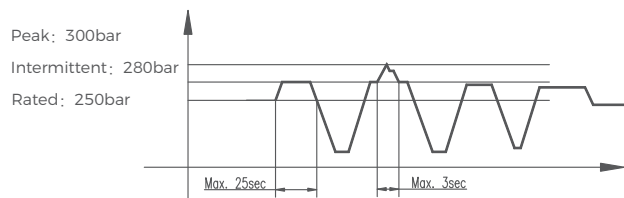

## General

To achieve the performance it necessary not only to meet the catalogue but also design the hydraulic system appropriately.

- The design of the hydraulic circle, especially the suction line, dimension and position of the valves, the filters, the reservoirs and the heat exchangers.
- Ensure correct and frequent cleaning and maintenance of the circle and of the hydraulic fluid.
- Equip the filter system with suitable alarm and safety devices.
- Avoid possible starting under load or at lower temperature .
- Avoid high pressure at low speed.
- Choose the hydraulic oil type reasonably.

## Hydraulic Fluid

Fluid must be specifically for hydraulic equipment, it must be foamless, anti-oxidative, anti-corrosiv and have good lubricating features meeting the following requirements.

Recommended use: GB11118-94: L-HM46 or equate NFE-603/DIN51524 II -85

## Minimum Working Speed

We recommend a minimum working speed for every pump group as follows

- 0P=800RPM
- 1P/3.5P/4P=600RPM
- 1AP ~ 2.5P=500RPM
- 3P=400RPM

## Hydraulic Circuits

- Avoid the line is locally too small restrictions and small radius bends.
- Place safety relief valve set at correct pressure and with good dynamic characteristic.
- Recommended fluid speed in the inlet line: 1.6 ~ 5ft/s(0.5 ~ 1.5m/s).
- Recommended fluid speed in the delivery line: 6.5 ~ 20ft/s(2 ~ 6m/s).
- Recommended fluid speed in the return line: 5 ~ 10ft/s(1.5 ~ 3m/s).
- Reservoir should have a capacity about twice as much as the volume of delivered by the pump in one minute.
- The return and inlet pipe must be separated as far as possible and under the minimum level of the oil.
- Install pump in a well cleaned environment, and make sure, prior starting the system that all pipe and reservoir are perfectly clean it is recommended to filter the new oil at 8 ~ 10 $\mu$ m , before filling the reservoir.
- Fill the pump with fluid before installing and check the direction of rotation.
- For the first run of the pump it is advisable to disconnect the pump in order to purge the air from the system.

## Recommended Fluid Cleanliness

- Many of premature failures of gear pumps are due to contamination, filter with clogging indicating and alarms is recommended.
- The initial contamination of the fluid must not exceed class 10 NAS 1638, pass experience has shown that even brand new fluid often exceed this value. In case we recommend to use filters larger than or equal to 80 $\mu$ m, for returning line we recommend to use the following filters.

Standard \ Pressure	P<2000PSI(14MPa)	2000PSI(14MPa)<P<3050PSI(21MPa)	P>3050PSI(21MPa)
NAS1638	10	9	8
ISO4406	19/16	18/15	17/14
Filter	25 $\mu$ m	20 $\mu$ m	10 $\mu$ m



## Driving Arrangements

- The center line of the pump shaft must be on the same axis line as the center line of the drive shaft, with a deviation of < 0.1 mm
- Do not apply radial or axial loads on the pump shafts, the use of three coupling is recommended.
- Make sure that the absorbed torque does not exceed the max torque allowed for the shaft.
- For gear pumps without front support, the belt and gear drives are not recommended because they apply axial and radial loads on the bearing.

## Calculated Formulas

Displacement	Flow	Pressure	Speed	Power	Torque	Volumetric efficiency	Mechanical efficiency	Total Efficiency
(cm <sup>3</sup> /r)	(l/min)	(bar)	(r/min)	(kw)	(N.m)	92%	85%	80%
V	Q	p	n	P	M	$\eta_v$	$\eta_m$	$\eta_t$

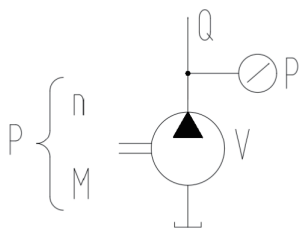

$$Q = V \cdot n \cdot \eta_v \cdot 10^3$$

$$M = p \cdot V / 62.83 \cdot \eta_m$$

$$P = p \cdot V \cdot n / 600 \cdot 1000 \cdot \eta_t$$

## General Notes

- Deliveries are carried out under the conditions of Guorui Hydraulics.
- The catalog only offers the outline connecting dimensions, we reserve the rights to change the design characteristics.
- Please contact us if you have special request.

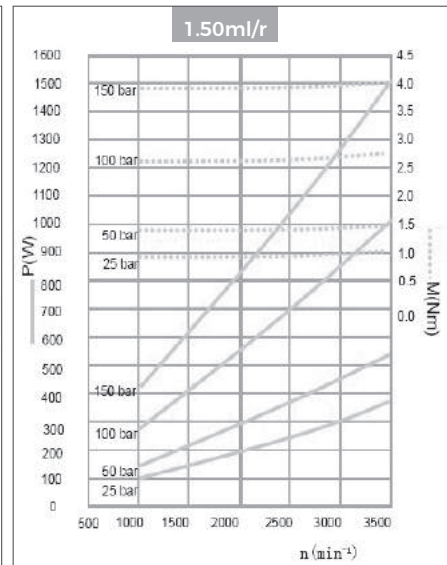
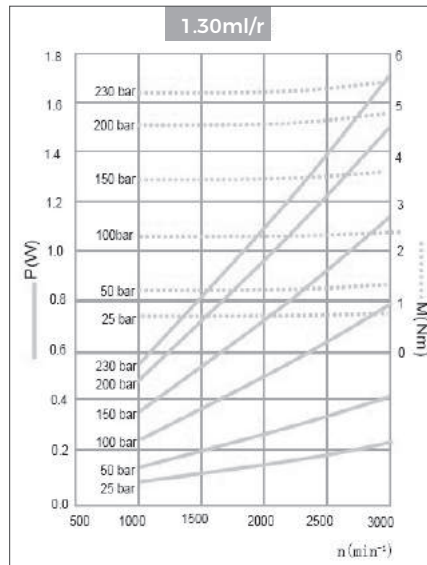
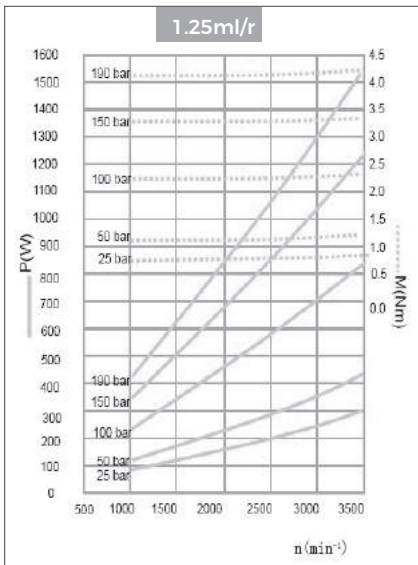
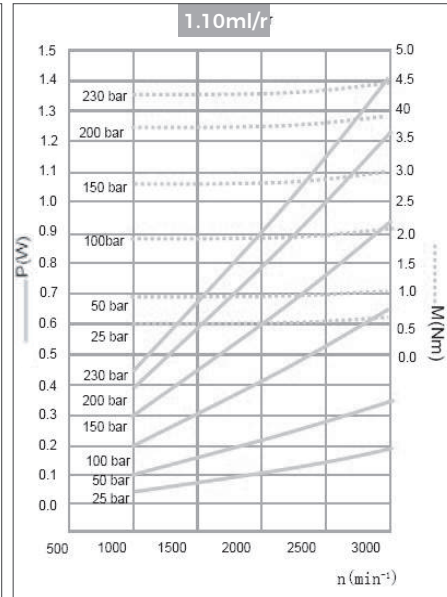
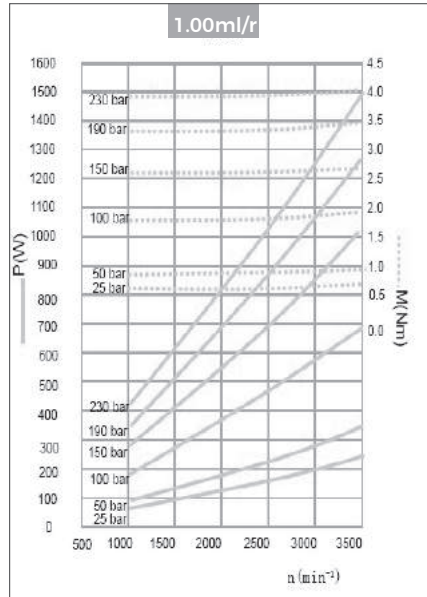
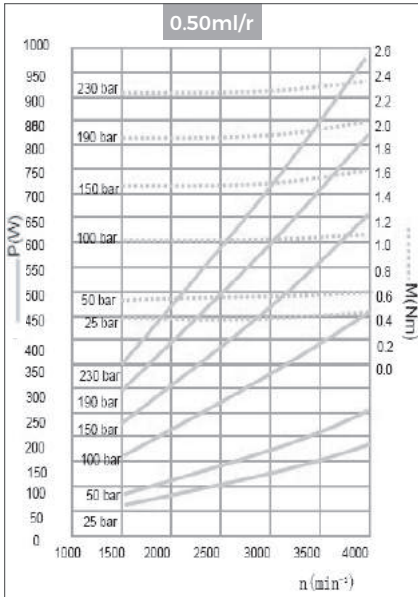
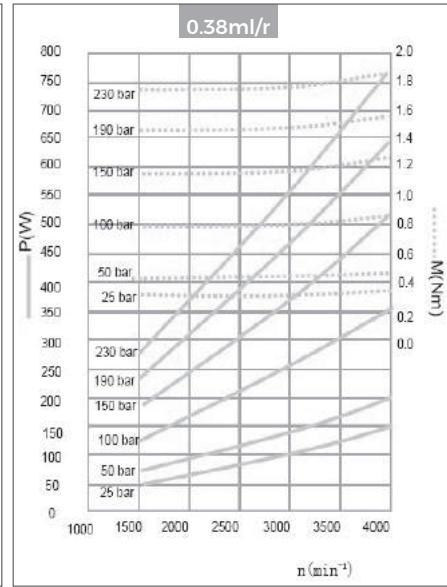
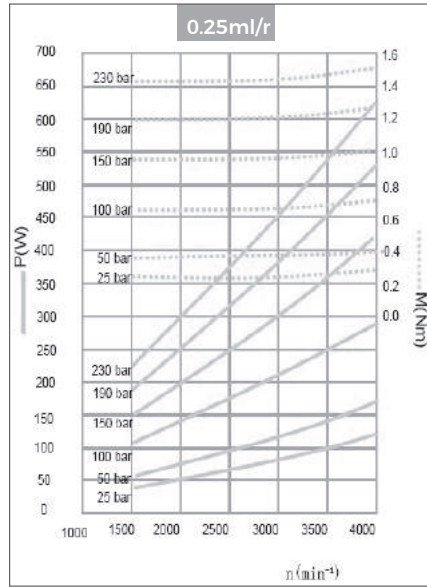
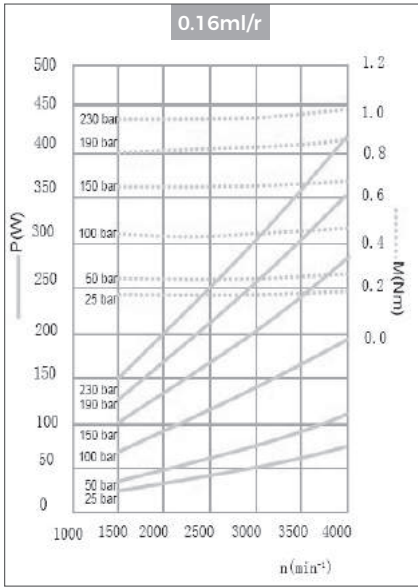

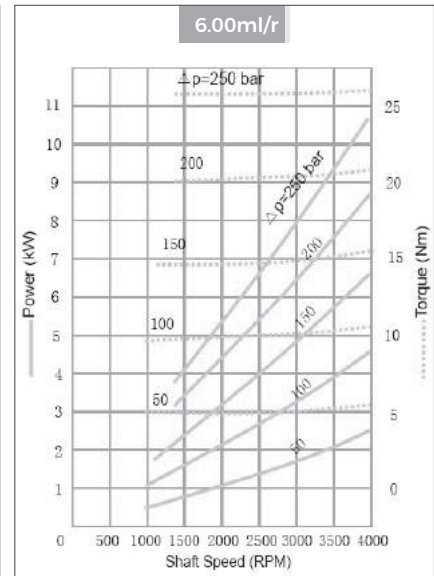
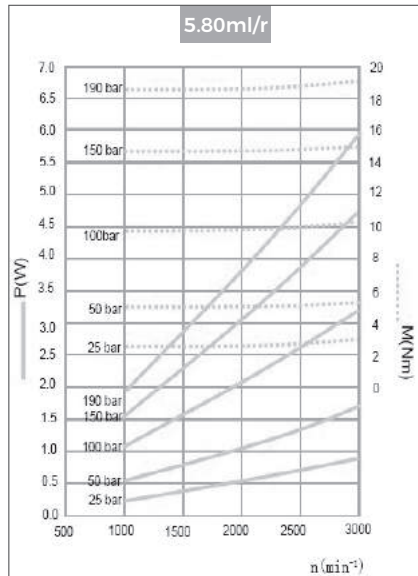
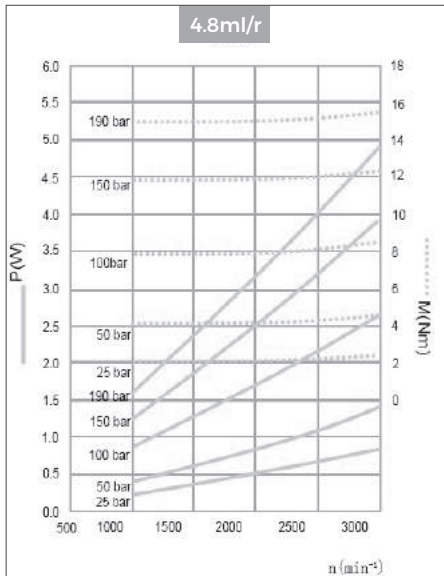
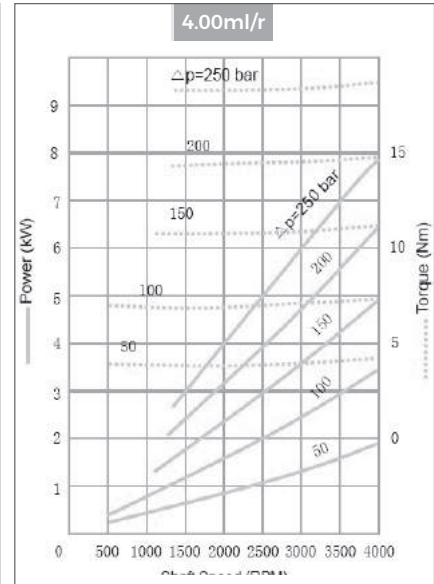
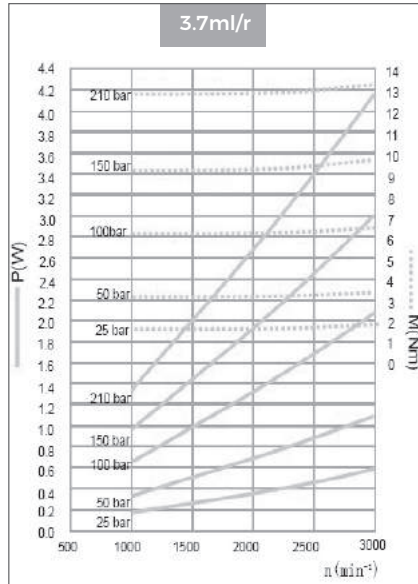
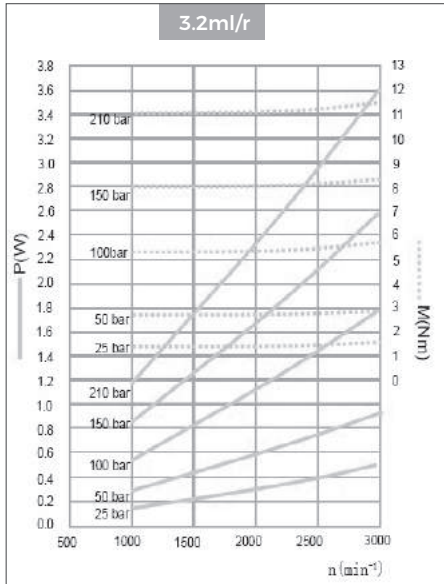
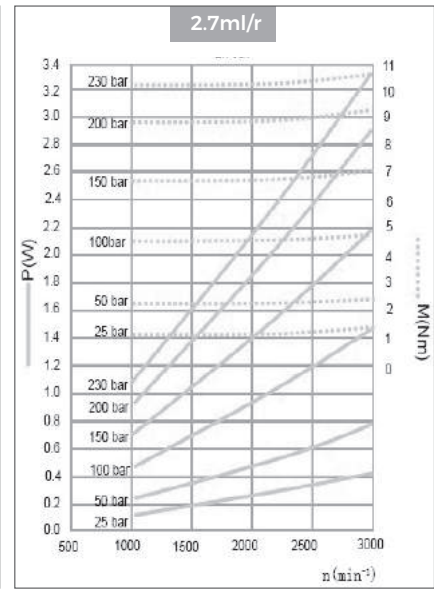
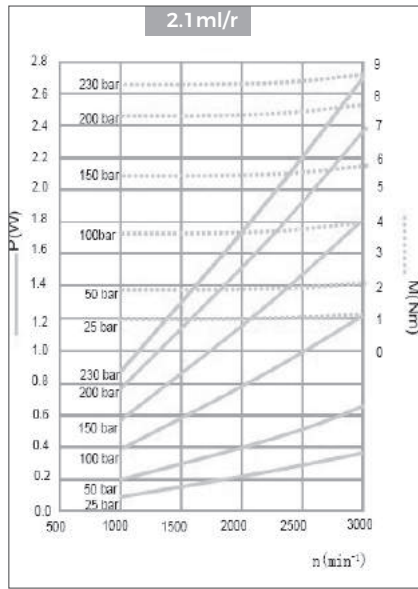
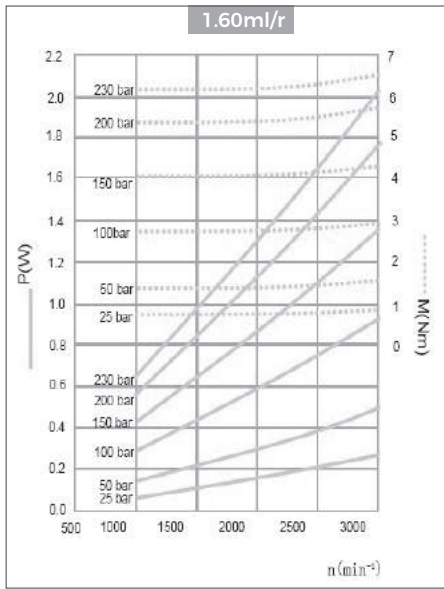



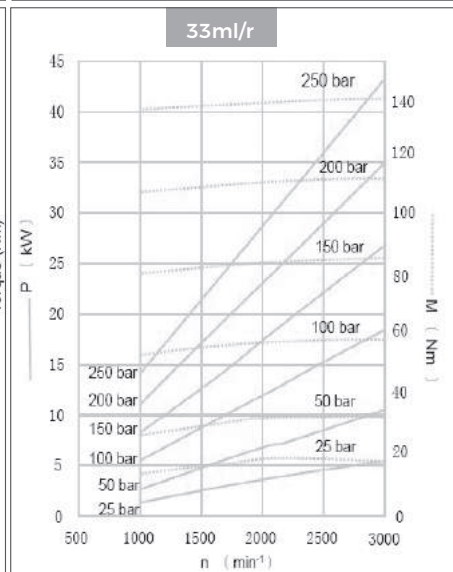
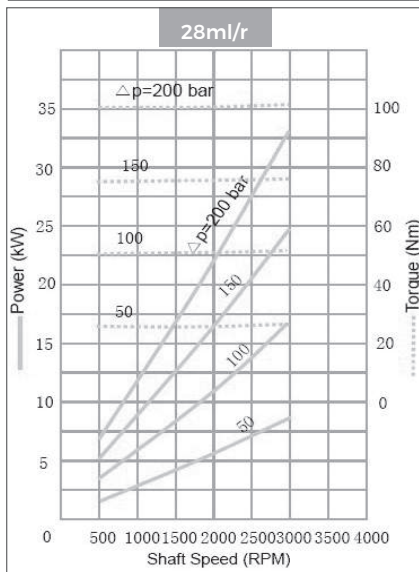
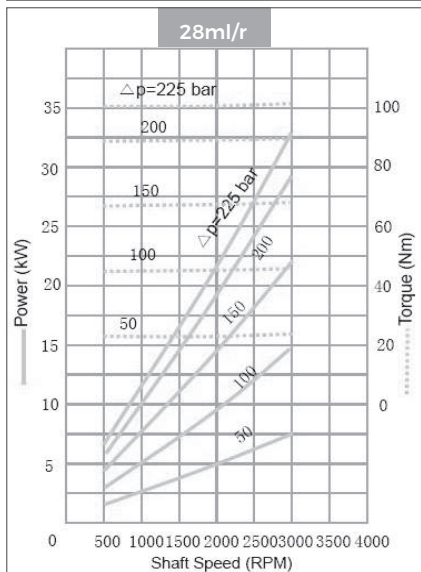
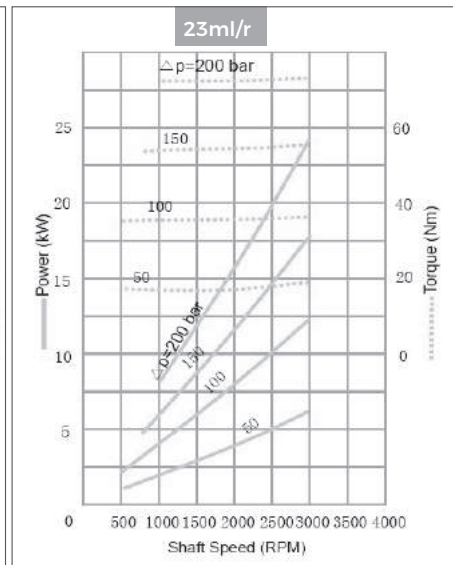
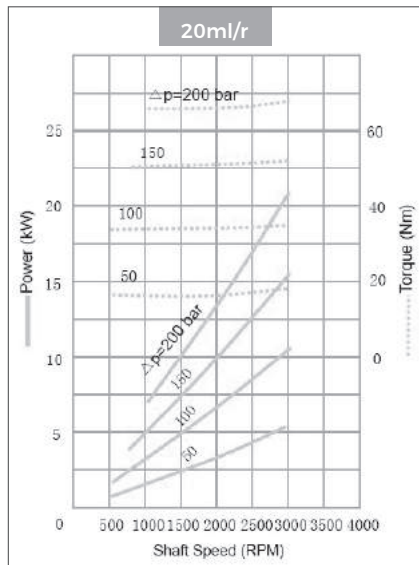
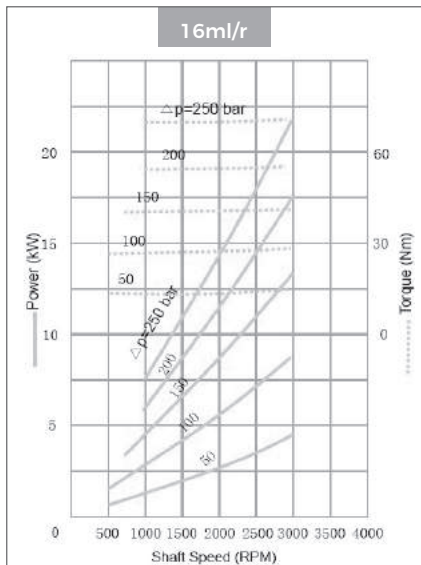
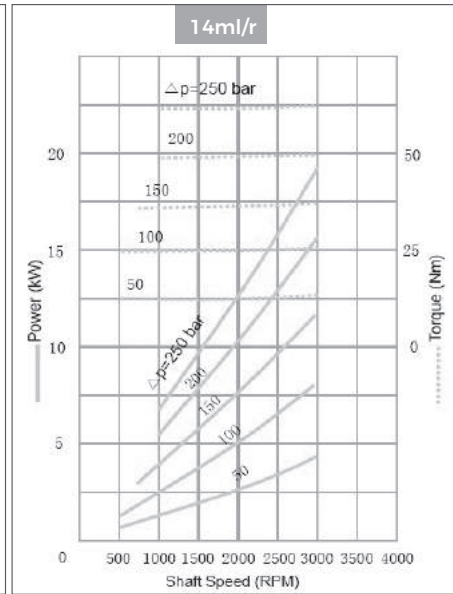
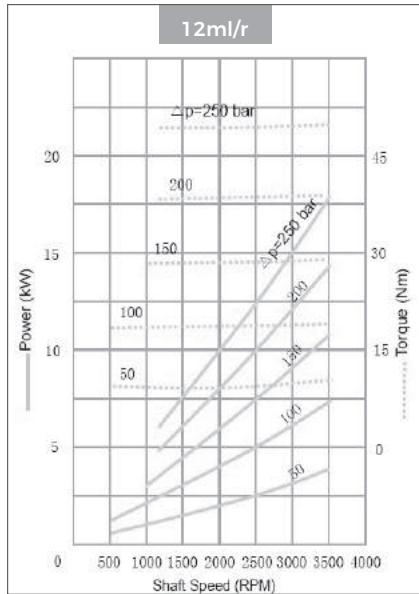
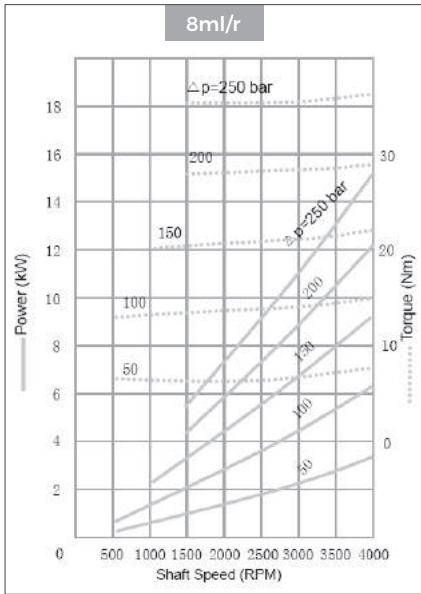

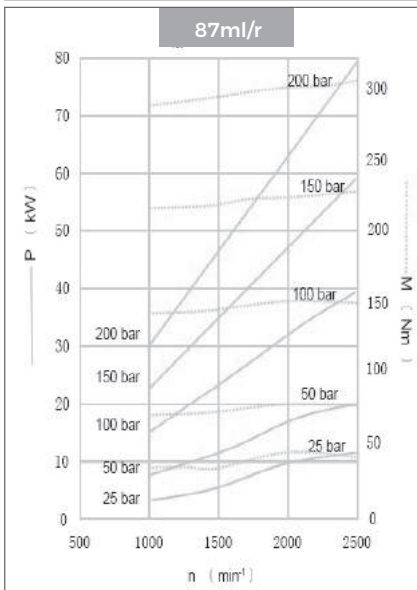
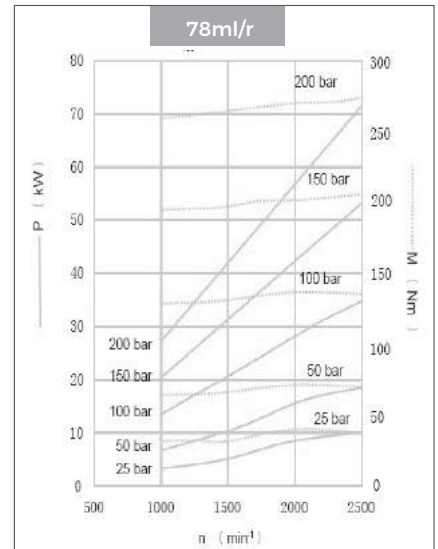
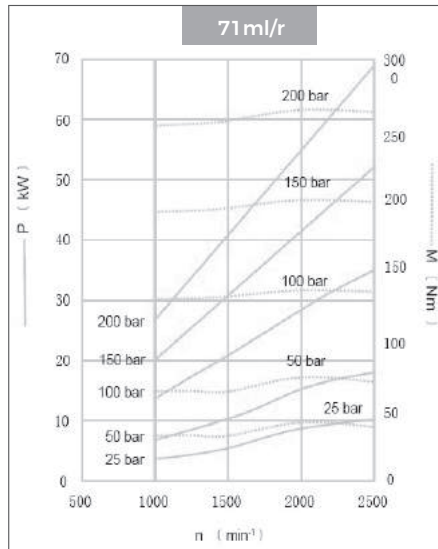
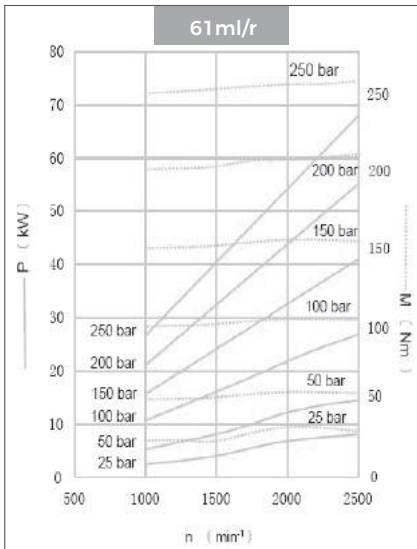
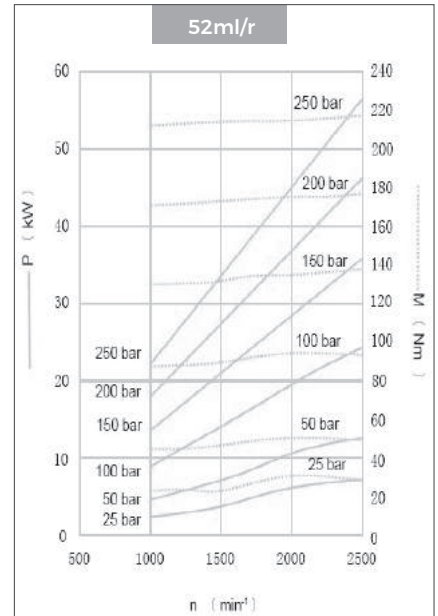
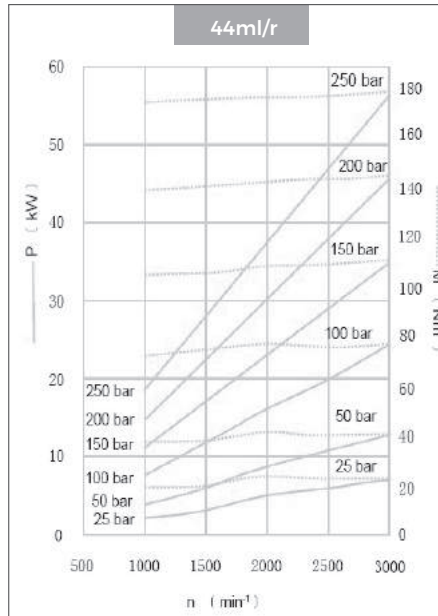
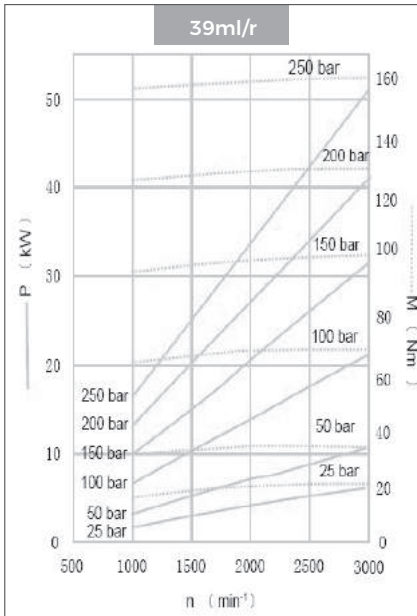









## Ordering Code

<b>0</b>	<b>P</b>	<b>F</b>	<b>0.16</b>	<b>L07</b>	<b>O3</b>	<b>O1</b>	<b>L-</b>	<b>BF-</b>	<b>F-</b>	<b>O</b>	<b>-V</b>
a	b	c	d	e	f	g	h	i	j	k	l

- (a) 0=Group 0  
 (b) P=Gear pump  
 (c) Pressure rate  
   E=160bar  
   F=200bar  
   G=250bar  
 (d) Displacement(ml/r)  
   0.16, 0.25, 0.38, 0.5, 0.75, 1, 1.25, 1.5, 1.75, 2  
 (e) L07=Line ports  
 (f) O3=Drive shaft  
 (g) O1=Front cover  
 (h) Rotation  
   R=CW  
   L=CCW  
   B=Bi-directional  
 (i) Ports combination  
   SS=Side inlet and side outlet  
   BF=Back inlet and front outlet  
   BB=Back inlet and back outlet  
 (j) Seal  
   F=FKM seal  
   Omit=NBR seal  
 (k) Outboard bearing  
   O=Outboard bearing  
   Omit=Without outboard bearing  
 (l) Option  
   V=Relief valve  
   D=Check valve

(e) Line ports Inlet/Outlet			(f) Drive shaft			(g) Front cover		
L07	G1/4 Ø5.5 x 9.6 x 1.45mm		O1	Oblate shaft Ø8mm x 5.5		O3	2-hole mounting 32 x 30mm	
L06	G1/4 G1/4		F1	Flat keyed shaft Ø7mm x 21				
K07	Ø9.6mm Ø5.5mm							
L61	M14 x 1.5 M14 x 1.5							

**OPF\*\*L\*\*O3O1\***



Model	Displacement (ml/r)	Pressure(bar)		Speed(r/min)			SS		Inlet
		Rated	Peak	Rated	Max.	Min.	L (mm)	L1 (mm)	
OPF0.16L07O3O1	0.16	200	250	3000	6000	800	58.2	30.8	G1/4
OPF0.25L07O3O1	0.25	200	250	3000	6000	800	59.0	31.3	
OPF0.38L07O3O1	0.38	200	250	3000	6000	800	60.3	31.9	
OPF0.50L07O3O1	0.50	200	250	3000	6000	800	61.0	32.3	
OPF0.75L07O3O1	0.75	200	250	3000	6000	800	63.5	33.5	
OPF1.00L07O3O1	1.00	200	250	3000	6000	800	66.0	34.8	
OPF1.25L07O3O1	1.25	200	250	3000	5000	800	68.5	36.0	
OPF1.50L07O3O1	1.50	200	250	3000	5000	800	70.0	37.0	
OPF1.75L07O3O1	1.75	160	200	3000	4500	800	73.0	38.3	
OPF2.00L07O3O1	2.00	160	200	3000	4500	800	75.5	39.5	

**Dimensions**

**OPF\*\*L06O3O1LSS**

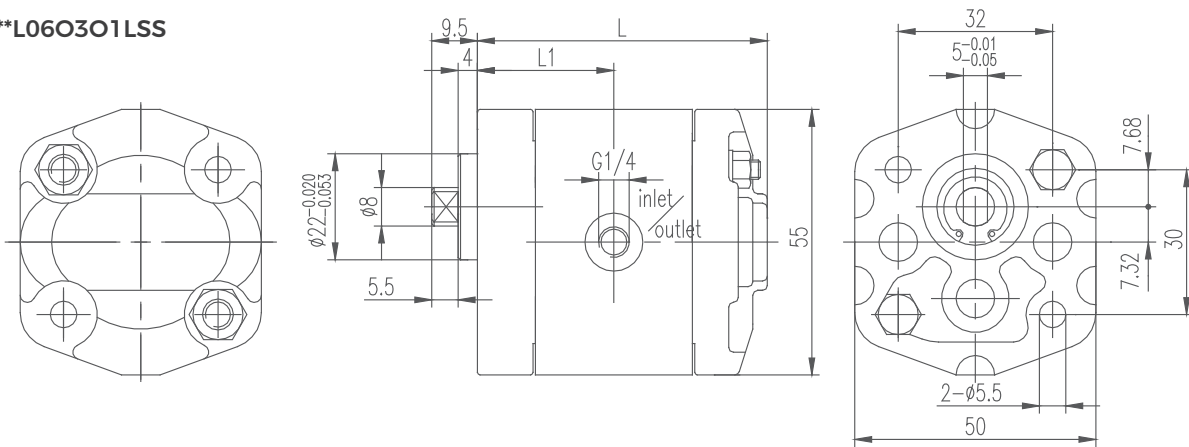

**OPF\*\*L07O3O1LBF**

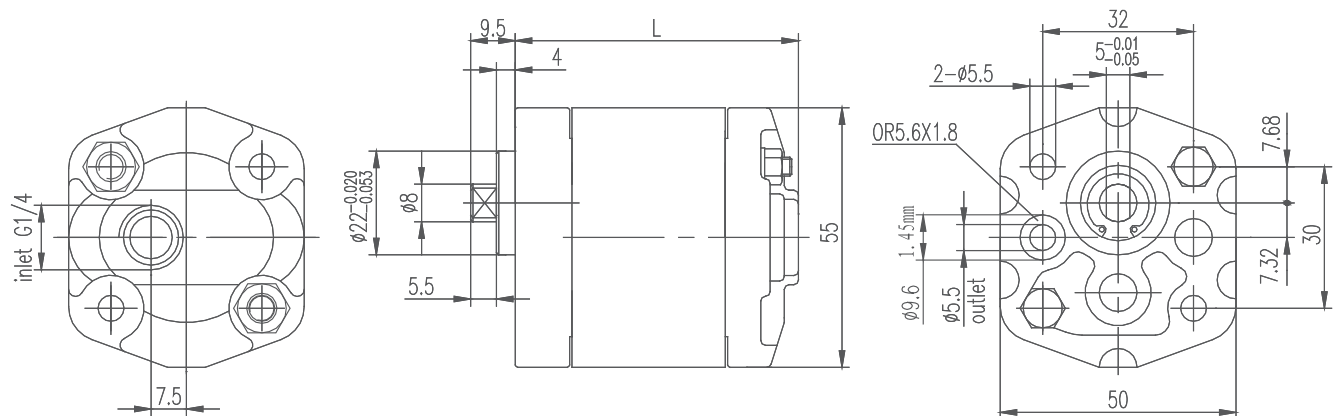



**0PF\*\*L\*\*O3O1B-BF-D**

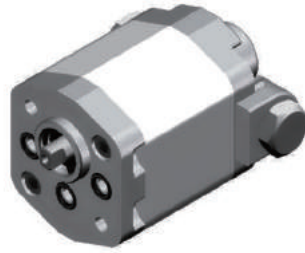

Model	Displacement (ml/r)	Pressure(bar)		Speed(r/min)			Rotation	Inlet	Outlet	Drain Port
		Rated	Peak	Rated	Max.	L(mm)				
0PF0.16L07O3O1B-BF-D	0.16	200	250	3000	6000	66.4	Bi	G1/4	ø5.5	ø5.5
0PF0.20L07O3O1B-BF-D	0.20	200	250	3000	6000	66.7				
0PF0.25L07O3O1B-BF-D	0.25	200	250	3000	6000	67.1				
0PF0.32L07O3O1B-BF-D	0.32	200	250	3000	6000	67.6				
0PF0.38L07O3O1B-BF-D	0.38	200	250	3000	6000	68.1				
0PF0.50L07O3O1B-BF-D	0.50	200	250	3000	6000	69.1				
0PF0.63L07O3O1B-BF-D	0.63	200	250	3000	6000	70.1				
0PF0.75L07O3O1B-BF-D	0.75	200	250	3000	6000	71.1				
0PF0.80L07O3O1B-BF-D	0.80	200	250	3000	6000	71.5				
0PF1.00L07O3O1B-BF-D	1.00	200	250	3000	6000	73.1				
0PF1.25L07O3O1B-BF-D	1.25	200	250	3000	5000	75.1				
0PF1.50L07O3O1B-BF-D	1.50	200	250	3000	5000	77.1				
0PF1.75L07O3O1B-BF-D	1.75	160	200	3000	4500	79.1				
0PF2.00L07O3O1B-BF-D	2.00	160	200	3000	4500	81.1				

**Dimensions**

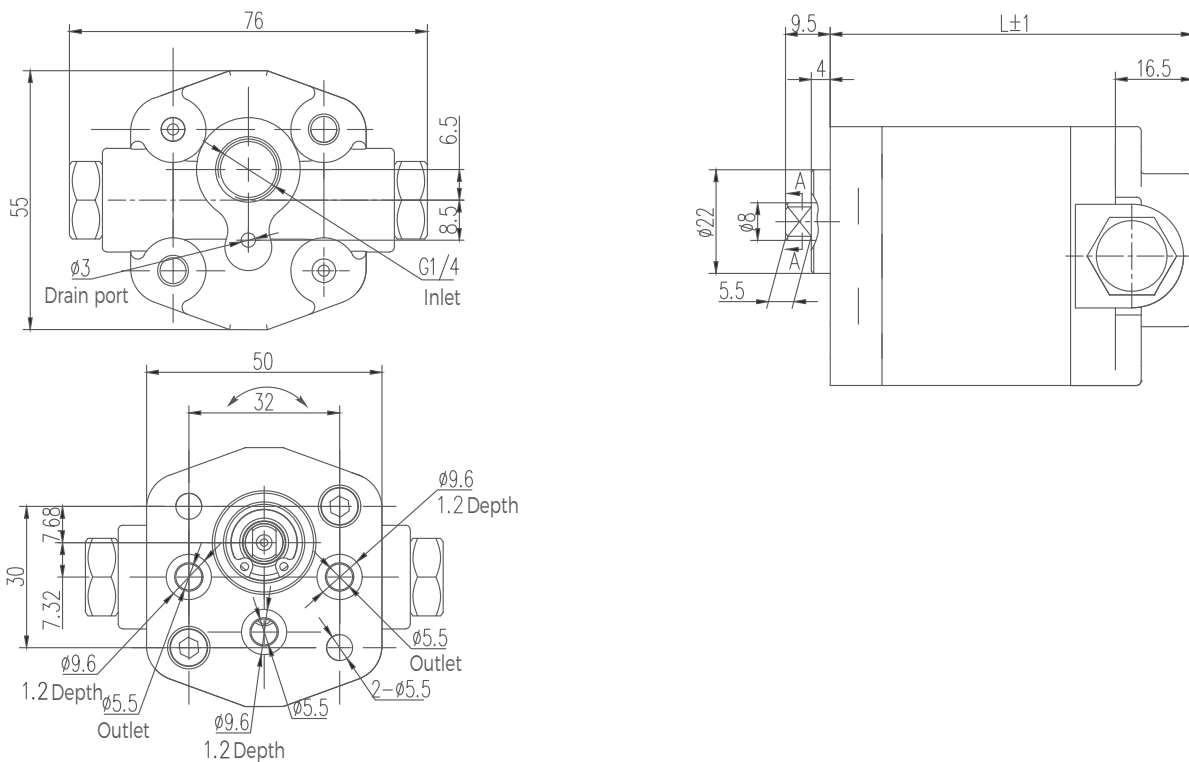

**OPF\*\*K07O3SP3B-BB**



Model	Displacement (ml/r)	Pressure(bar)		Speed(r/min)			Rotation	Inlet and Outlet	Drain Port
		Rated	Peak	Rated	Max.	L(mm)			
OPF0.16K07O3SP3B-BB	0.16	200	250	3000	6000	60.9	Bi	ø5.5	ø5.5
OPF0.20K07O3SP3B-BB	0.20	200	250	3000	6000	61.2			
OPF0.25K07O3SP3B-BB	0.25	200	250	3000	6000	61.6			
OPF0.32K07O3SP3B-BB	0.32	200	250	3000	6000	62.1			
OPF0.38K07O3SP3B-BB	0.38	200	250	3000	6000	62.5			
OPF0.50K07O3SP3B-BB	0.50	200	250	3000	6000	63.5			
OPF0.63K07O3SP3B-BB	0.63	200	250	3000	6000	64.5			
OPF0.75K07O3SP3B-BB	0.75	200	250	3000	6000	65.6			
OPF0.80K07O3SP3B-BB	0.80	200	250	3000	6000	66.0			
OPF1.00K07O3SP3B-BB	1.00	200	250	3000	6000	67.6			
OPF1.25K07O3SP3B-BB	1.25	200	250	3000	5000	69.6			
OPF1.50K07O3SP3B-BB	1.50	200	250	3000	5000	71.6			
OPF1.75K07O3SP3B-BB	1.75	160	200	3000	4500	73.6			
OPF2.00K07O3SP3B-BB	2.00	160	200	3000	4500	75.6			

**Dimensions**

**OPF\*\*K07O3SP3B-BB**

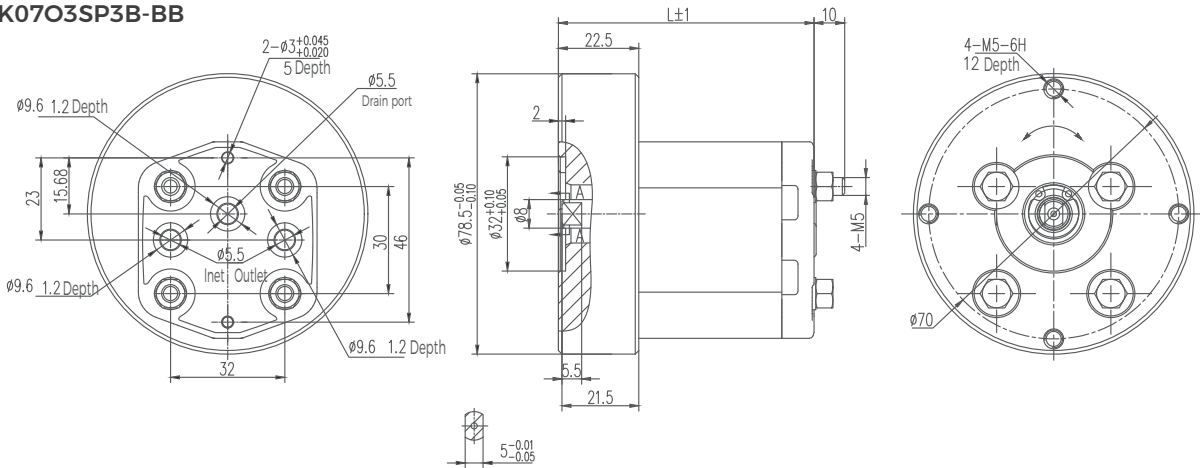

**OPF\*\*K07O3SP3HB-BB**

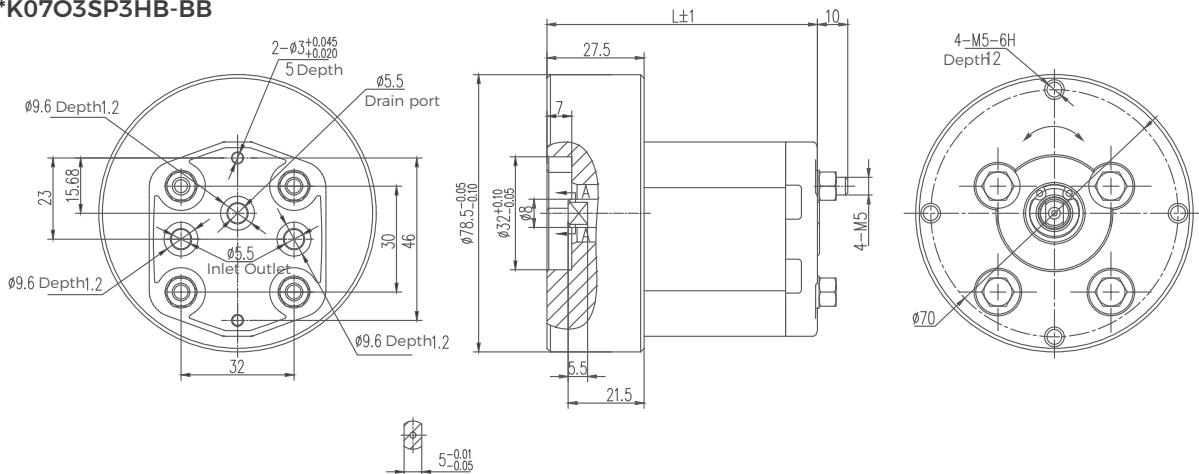



OPF\*\*L\*\*F1D1\*



Model	Displacement (ml/r)	Pressure(bar)		Speed(r/min)			L(mm)	L1(mm)
		Rated	Peak	Rated	Max.	Min.		
OPF0.16L61F1D1*	0.16	200	250	3000	6000	800	57.7	26.9
OPF0.25L61F1D1*	0.25	200	250	3000	6000	800	58.5	27.3
OPF0.38L61F1D1*	0.38	200	250	3000	6000	800	59.8	27.9
OPF0.50L61F1D1*	0.50	200	250	3000	6000	800	60.5	28.3
OPF0.63L61F1D1*	0.63	200	250	3000	6000	800	62.0	29.0
OPF0.75L61F1D1*	0.75	200	250	3000	6000	800	63.0	29.5
OPF1.00L61F1D1*	1.00	200	250	3000	6000	800	65.5	30.8
OPF1.25L61F1D1*	1.25	200	250	3000	5000	800	68.0	32.0
OPF1.50L61F1D1*	1.50	200	250	3000	5000	800	70.0	33.0
OPF1.75L61F1D1*	1.75	160	200	3000	4500	800	72.5	34.3
OPF2.00L61F1D1*	2.00	160	200	3000	4500	800	75.0	35.5



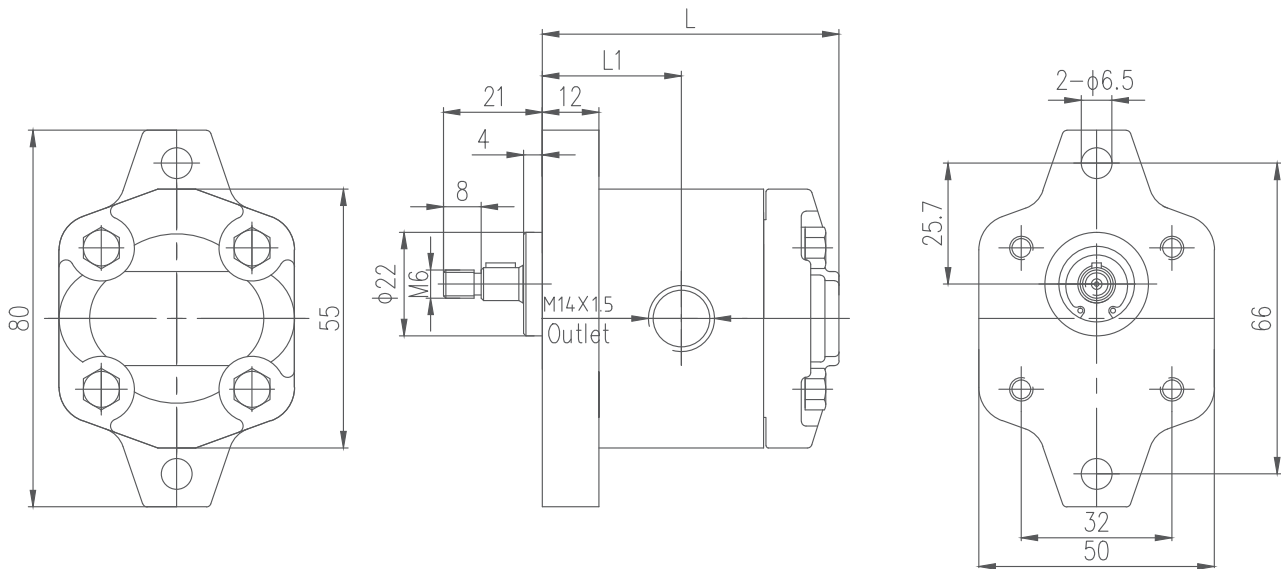







## Dimensions



## Ordering Code

<b>1</b>	<b>*</b>	<b>P</b>	<b>F</b>	<b>2.7</b>	<b>L01</b>	<b>O11</b>	<b>O2</b>	<b>L-</b>	<b>SS</b>	<b>F-</b>	<b>O</b>	<b>-V</b>
a	b	c	d	e	f	g	h	i	j	k	l	m

- Ⓐ 1=Group 1
- Ⓑ Improved number  
Omit=Aluminum cover and body  
A=Cast iron cover  
AB=Low noise  
QC/QE=Special type
- Ⓒ P=Gear pump
- Ⓓ Pressure rate  
E=160bar  
F=200bar  
G=250bar
- Ⓔ Displacement(ml/r)  
1.1, 1.3, 1.6, 1.8, 2.1, 2.7, 3.2, 3.7, 4.2, 4.8, 5.8, 8
- Ⓕ L01=Line ports
- Ⓖ O11=Drive shaft
- Ⓗ O2=Front cover
- Ⓘ Rotation  
R=CW  
L=CCW  
B=Bi-directional
- Ⓛ Ports combination  
SS=Side inlet and side outlet  
SB=Side inlet and back outlet  
BS=Back inlet and side outlet
- Ⓚ Seal  
F=FKM seal  
Omit=NBR seal
- Ⓛ Outboard bearing  
O=Outboard bearing  
Omit=Without outboard bearing
- Ⓜ Option  
V=Relief valve  
D=Check valve

Ⓕ Line ports Inlet/Outlet			Ⓖ Drive shaft			Ⓗ Front cover		
L01	G3/8 Ø9 x 12.7 x 1.45mm		O11	Oblate shaft Ø5mm x 7		O2	2-hole mounting 40 x 40mm	
L46	G3/8 G3/8		T3	Tapered key shaft 1:5		S5	4-hole mounting 52.4 x 71.9mm	
L04	G1/2 G1/2		F16	Flat keyed shaft SAE AA Ø12.7mm		D2	2-groove mounting Ø82.55mm	
L05	G1/2 G3/8							
LJ37	7/8-14UNF-2B 3/4-16UNF-2B							

1PF\*\*\*L\*\*O11O2\*



Model	Displacement (ml/r)	Pressure(bar)		Speed(r/min)			L(mm)	L1(mm)	L2(mm)	Inlet SS
		Rated	Peak	Rated	Max.	Min.				
1PF1.1L01O11O2*	1.1	200	250	3000	6000	600	74	63	33.0	G3/8
1PF1.3L01O11O2*	1.3	200	250	3000	6000	600	75	64	33.5	
1PF1.6L01O11O2*	1.6	200	250	3000	6000	600	76	65	34.0	
1PF1.8L01O11O2*	1.8	200	250	3000	6000	600	77	66	34.5	
1PF2.1L01O11O2*	2.1	200	250	3000	6000	600	78	67	35.0	
1PF2.7L01O11O2*	2.7	200	250	3000	6000	600	80	69	36.0	
1PF3.2L01O11O2*	3.2	200	250	3000	5000	600	82	71	37.0	
1PF3.7L01O11O2*	3.7	200	250	3000	4500	600	84	73	38.0	
1PF4.2L01O11O2*	4.2	200	250	3000	4000	600	86	75	39.0	
1PF4.8L01O11O2*	4.8	160	200	3000	3500	600	88	77	40.0	
1PF5.8L01O11O2*	5.8	160	200	3000	3500	600	92	81	42.0	
1PF8.0L01O11O2*	8.0	160	200	3000	3500	600	100	89	46.0	

Dimensions

1PF\*\*\*L01O11O2

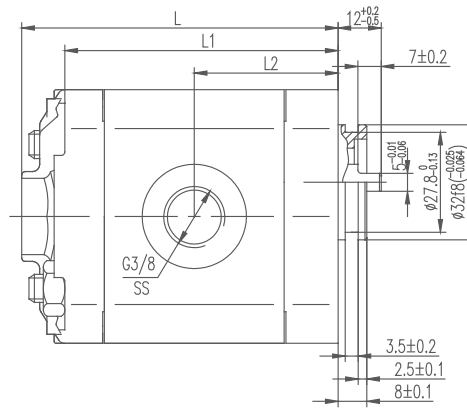
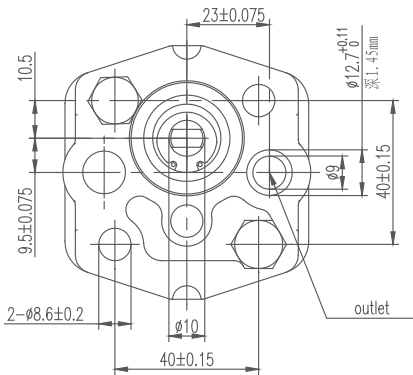

Option: With Relief Valve

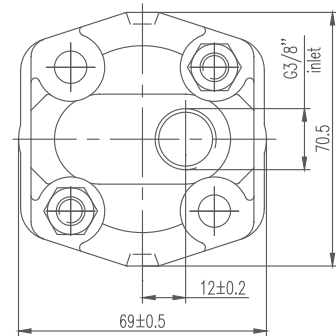

1PF\*\*\*L01O11O2-BF-V

Adjustable Pressure of Relief Valve 50–250 Bar

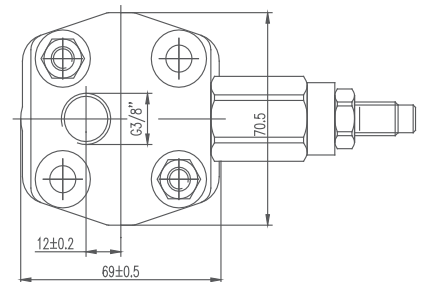
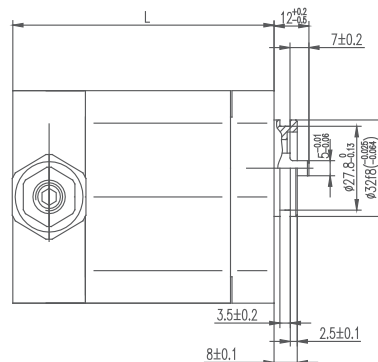
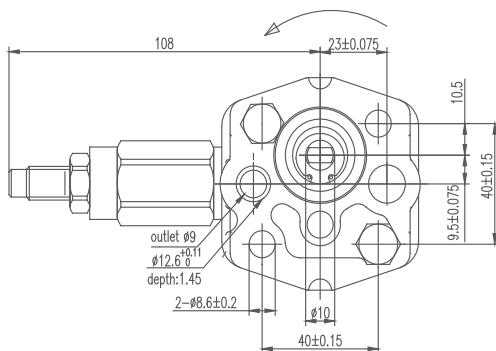

## 1PF\*\*L\*\*T3S5\*



Model	Displacement (ml/r)	Pressure(bar)		Speed(r/min)			L(mm)	L1(mm)
		Rated	Peak	Rated	Max.	Min.		
1PF1.1L46T3S5*	1.1	200	250	3000	6000	600	75.0	33.0
1PF1.3L46T3S5*	1.3	200	250	3000	6000	600	76.0	34.0
1PF1.6L46T3S5*	1.6	200	250	3000	6000	600	78.0	35.0
1PF1.8L46T3S5*	1.8	200	250	3000	6000	600	78.5	35.5
1PF2.1L46T3S5*	2.1	200	250	3000	6000	600	79.0	36.0
1PF2.7L46T3S5*	2.7	200	250	3000	6000	600	81.0	37.0
1PF3.2L46T3S5*	3.2	200	250	3000	5000	600	83.0	38.0
1PF3.7L46T3S5*	3.7	200	250	3000	4500	600	85.0	39.0
1PF4.2L46T3S5*	4.2	200	250	3000	4000	600	87.0	40.0
1PF4.8L46T3S5*	4.8	160	200	3000	3500	600	89.0	41.0
1PF5.8L46T3S5*	5.8	160	200	3000	3500	600	93.0	43.0
1PF8.0L46T3S5*	8.0	160	200	3000	3500	600	101.0	47.0

## Dimensions

## 1PF\*\*L46T3S5S

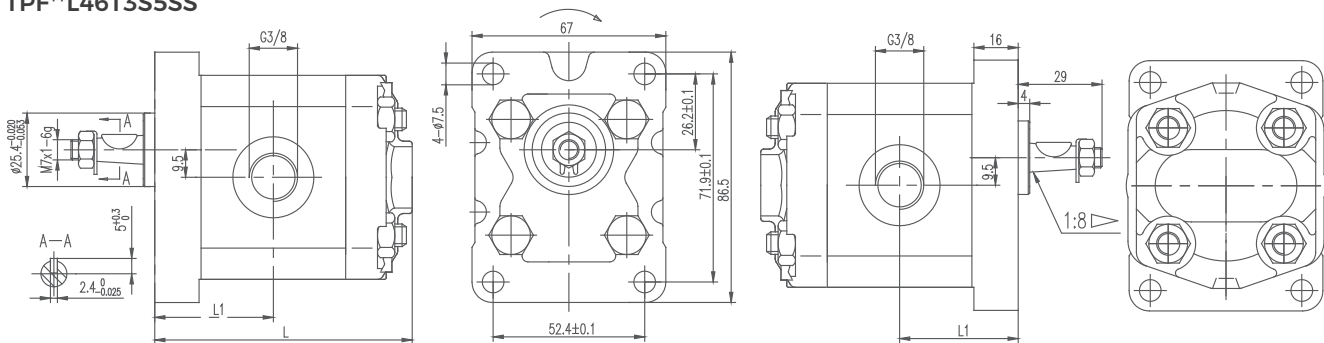

## 1PF\*\*\*L46T3S5-V

Option: With Relief Valve

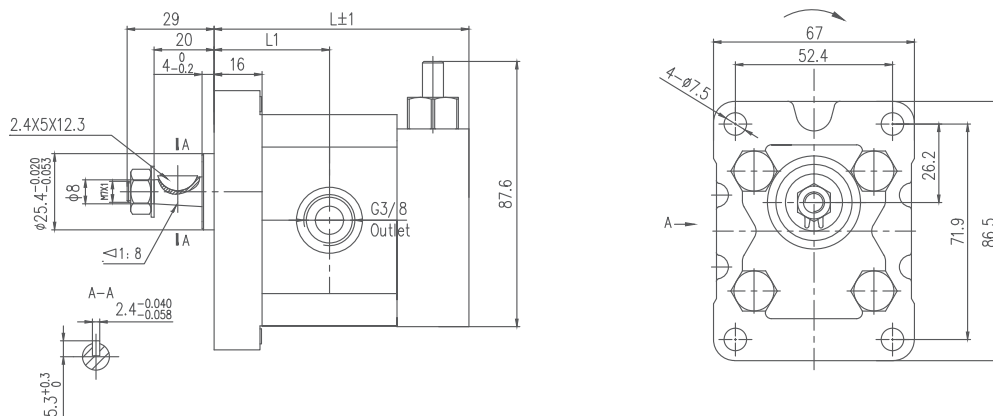

**1PF\*\*L04F9SP15L-O-V-J**

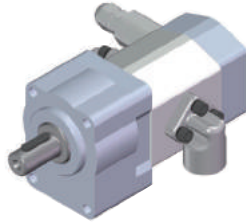

Model	Displacement (ml/r)	Pressure(bar)		Speed(r/min)			L(mm)	L1(mm)
		Rated	Peak	Rated	Max.	Min.		
1PF1.1L04F9SP15L-O-V-J	1.1	200	250	3000	6000	600	75.0	33.0
1PF1.3L04F9SP15L-O-V-J	1.3	200	250	3000	6000	600	76.0	34.0
1PF1.6L04F9SP15L-O-V-J	1.6	200	250	3000	6000	600	78.0	35.0
1PF1.8L04F9SP15L-O-V-J	1.8	200	250	3000	6000	600	78.5	35.5
1PF1.1L04F9SP15L-O-V-J	2.1	200	250	3000	6000	600	79.0	36.0
1PF2.7L04F9SP15L-O-V-J	2.7	200	250	3000	6000	600	81.0	37.0
1PF3.2L04F9SP15L-O-V-J	3.2	200	250	3000	5000	600	83.0	38.0
1PF3.7L04F9SP15L-O-V-J	3.7	200	250	3000	4500	600	85.0	39.0
1PF4.2L04F9SP15L-O-V-J	4.2	200	250	3000	4000	600	87.0	40.0
1PF4.8L04F9SP15L-O-V-J	4.8	160	200	3000	3500	600	89.0	41.0
1PF5.8L04F9SP15L-O-V-J	5.8	160	200	3000	3500	600	93.0	43.0
1PF8.0L04F9SP15L-O-V-J	8.0	160	200	3000	3500	600	101.0	47.0

**Dimensions**

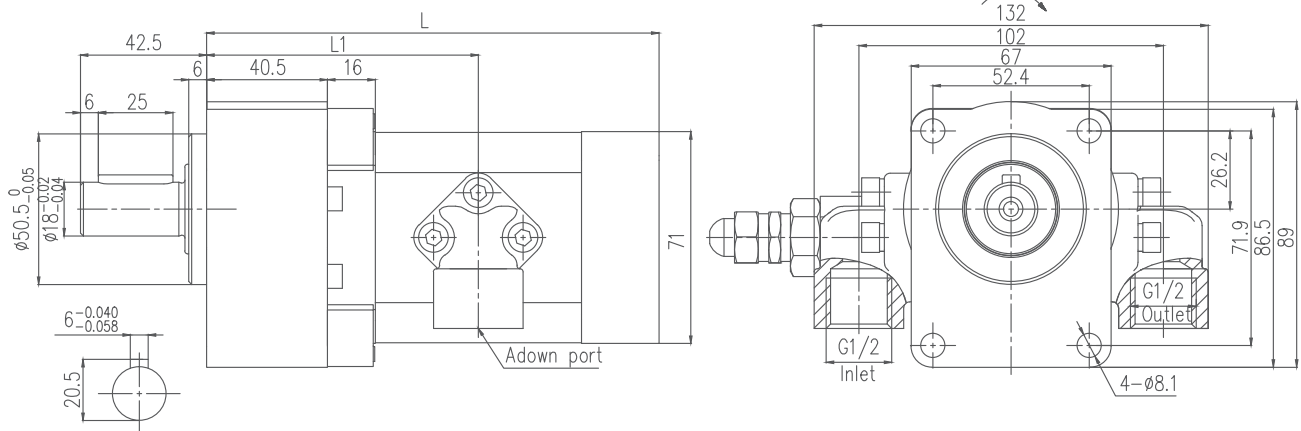



**1HPF\*\*L147S93SP4LFB**

Model	Displacement (ml/r)	Pressure(bar)		Speed(r/min)			L(mm)	L1(mm)
		Rated	Peak	Rated	Max.	Min.		
1HPF1.1L147S93SP4LFB	1.1	140	200	3000	4000	600	79	40
1HPF1.3L147S93SP4LFB	1.3	140	200	3000	4000	600	79	40
1HPF1.6L147S93SP4LFB	1.6	140	200	3000	4000	600	79	40
1HPF1.8L147S93SP4LFB	1.8	140	200	3000	4000	600	79	40
1HPF2.1L147S93SP4LFB	2.1	140	200	3000	4000	600	79	40
1HPF2.3L147S93SP4LFB	2.3	140	200	3000	4000	600	79	40
1HPF2.5L147S93SP4LFB	2.5	140	200	3000	4000	600	79	40
1HPF2.7L147S93SP4LFB	2.7	140	200	3000	4000	600	79	40
1HPF3.2L147S93SP4LFB	3.2	140	250	3000	4000	600	99	60
1HPF3.3L147S93SP4LFB	3.3	140	200	3000	4000	600	99	60
1HPF3.4L147S93SP4LFB	3.4	140	200	3000	4000	600	99	60
1HPF3.7L147S93SP4LFB	3.7	140	200	3000	4000	600	99	60
1HPF4.2L147S93SP4LFB	4.2	140	200	3000	4000	600	99	60
1HPF4.8L147S93SP4LFB	4.8	140	200	3000	4000	600	99	60
1HPF5.8L147S93SP4LFB	5.8	140	200	3000	4000	600	99	60
1HPF6.0L147S93SP4LFB	6.0	140	200	3000	4000	600	99	60
1HPF6.2L147S93SP4LFB	6.2	140	200	3000	4000	600	99	60
1HPF7.0L147S93SP4LFB	7.0	140	200	3000	4000	600	99	60
1HPF8.0L147S93SP4LFB	8.0	140	200	3000	4000	600	101	60

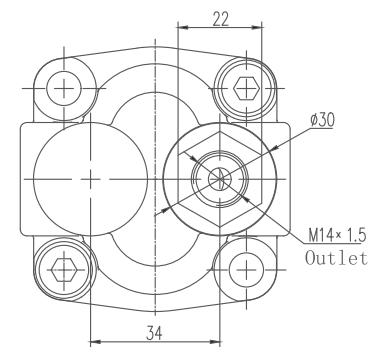
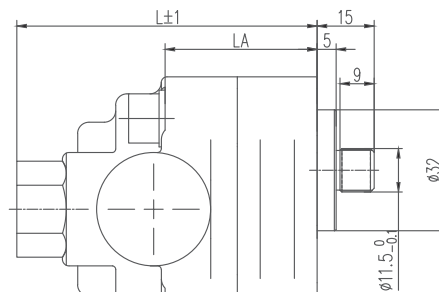
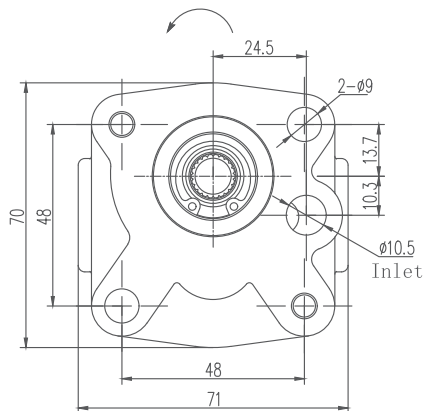
**Dimensions**

**1APF\*\*\*L\*\*F16D2\***

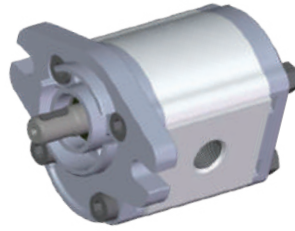

Model	Displacement (ml/r)	Pressure(bar)		Speed(r/min)			A(mm)	B(mm)	D	
		Rated	Peak	Rated	Max.	Min.			In	Out
1APF1.3L05F16D2*	1.3	200	250	3000	4500	500	82	42.0	G1/2	G3/8
1APF2.0L05F16D2*	2.0	200	250	3000	4500	500	84	43.0		
1APF2.7L05F16D2*	2.7	200	250	3000	4500	500	86	44.0		
1APF3.4L05F16D2*	3.4	200	250	3000	4500	500	88	45.0		
1APF4.1L05F16D2*	4.1	200	250	3000	4500	500	90	46.0		
1APF5.1L05F16D2*	5.1	200	250	3000	4500	500	93	47.5		
1APF6.1L05F16D2*	6.1	200	250	3000	4500	500	96	49.0		
1APF7.1L05F16D2*	7.1	200	250	3000	4500	500	101	50.5		

**Dimensions**

**1APF\*\*\*L\*\*F16D2\***

Option: 1APF With Relief Valve

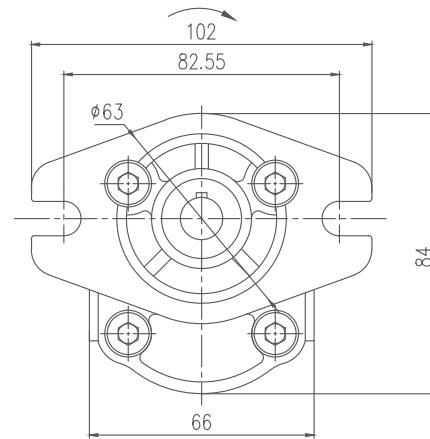
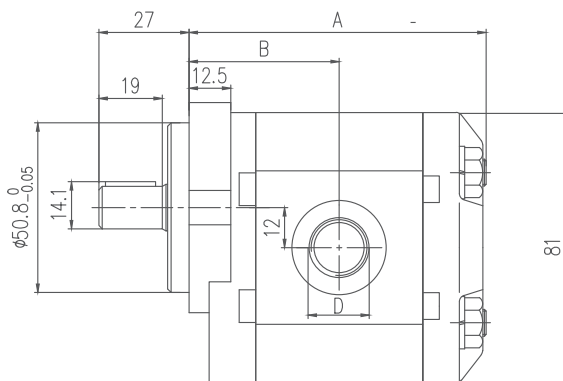

**1APF\*\*LJ35F16D4L**

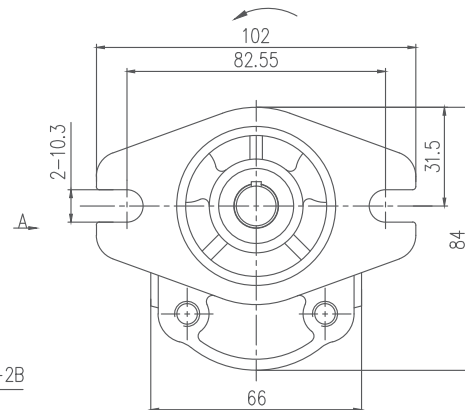
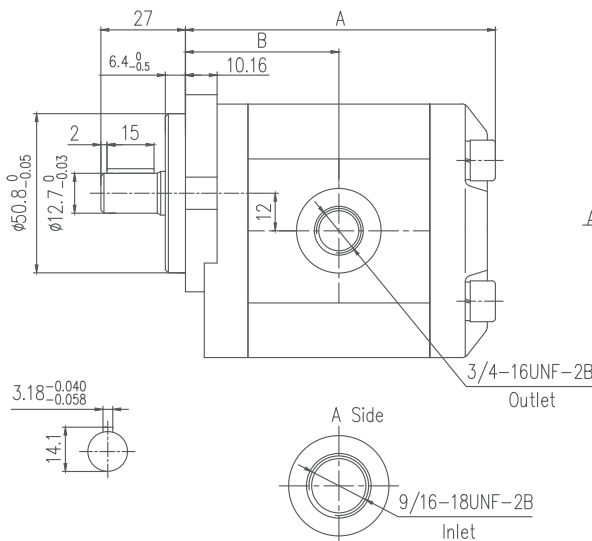

## 1QEPF\*\*K06T48SP6



Model	Displacement (ml/r)	Pressure(bar)		Speed(r/min)			L(mm)
		Rated	Peak	Rated	Max.	Min.	
1QEPF0.8K06T48SP6	0.8	200	250	3000	4000	500	80.3
1QEPF1.1K06T48SP6	1.1	200	250	3000	4000	500	80.8
1QEPF1.6K06T48SP6	1.6	200	250	3000	4000	500	82.8
1QEPF2.5K06T48SP6	2.5	200	250	3000	4000	500	86.3
1QEPF3.2K06T48SP6	3.2	200	250	3000	3500	500	80.0

## Dimensions

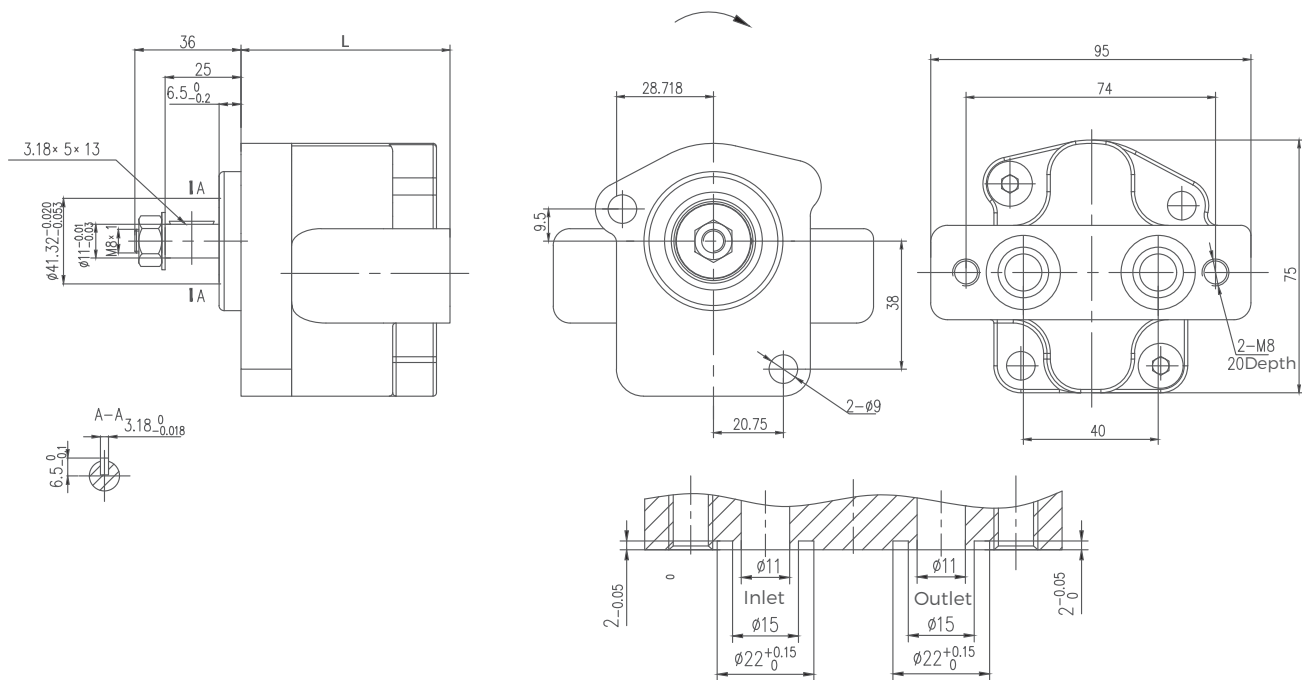

**1QCPF\*\*L\*\*O30SP5\***



Model	Displacement (ml/r)	Pressure(bar)		Speed(r/min)			L(mm)	L1(mm)
		Rated	Peak	Rated	Max.	Min.		
1QCPF0.8L04O30SP5*	0.8	200	250	3000	4000	500	80.3	40.8
1QCPF1.1L04O30SP5*	1.1	200	250	3000	4000	500	80.8	41.0
1QCPF1.6L04O30SP5*	1.6	200	250	3000	4000	500	82.8	42.0
1QCPF2.5L04O30SP5*	2.5	200	250	3000	4000	500	86.3	43.8
1QCPF3.2L04O30SP5*	3.2	200	250	3000	4000	500	88.8	45.0

**Dimensions**

**1QCPF\*\*L04O30SP5L**

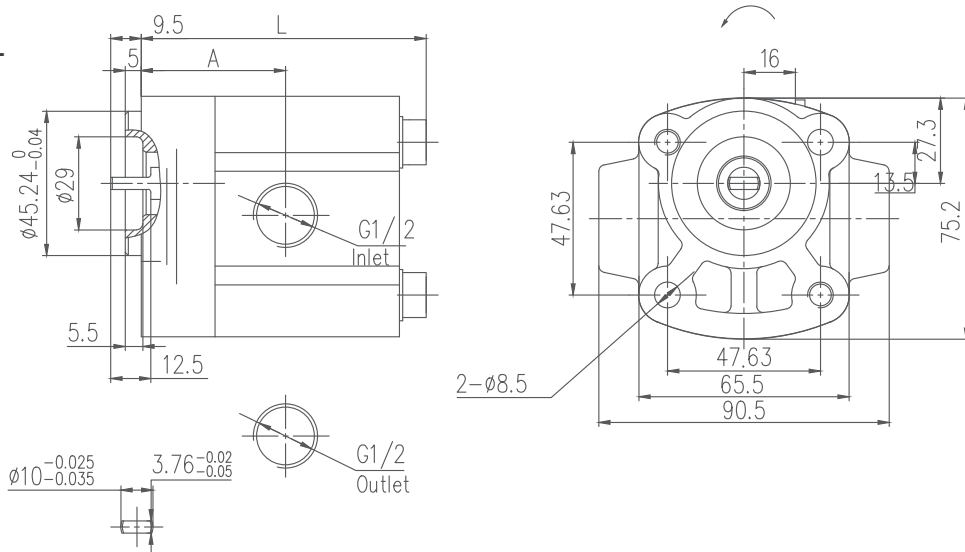

**1QCPF\*\*LJ37O31SP5L**

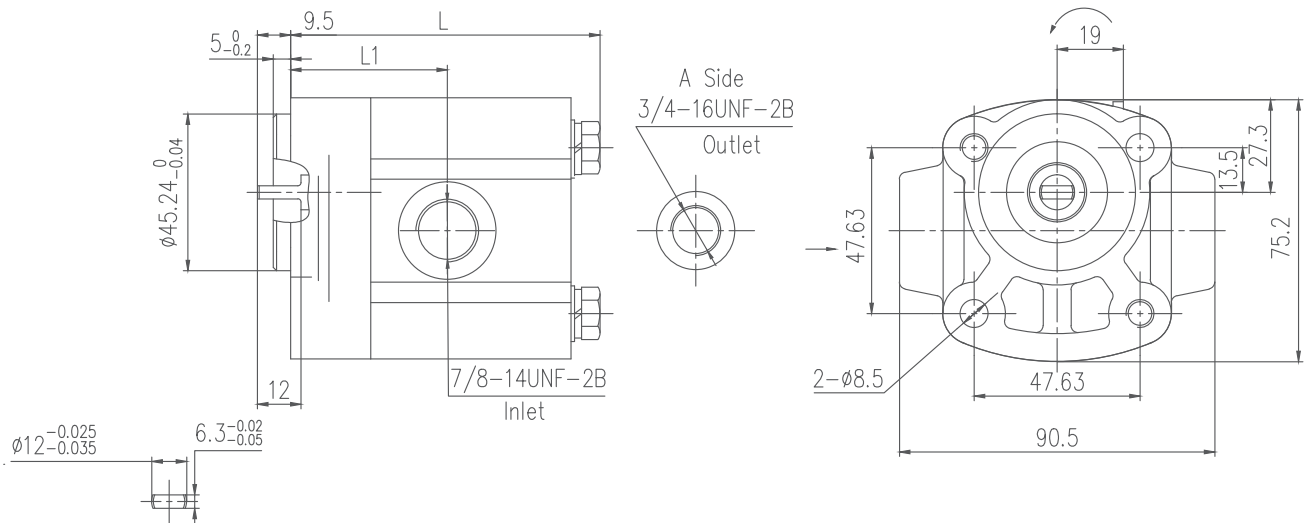

## Ordering Code

<b>1.5</b>	<b>P</b>	<b>F</b>	<b>9</b>	<b>F50</b>	<b>F13</b>	<b>S3</b>	<b>L-</b>	<b>F-</b>	<b>O</b>	<b>-V</b>
a	b	c	d	e	f	g	h	i	j	k

Ⓐ 1.5=Group 1.5

Ⓑ P=Gear pump

Ⓒ Pressure rate

E=160bar

F=200bar

G=250bar

Ⓓ Displacement(ml/r)

2, 3, 4, 5, 6, 8, 9, 11, 12

Ⓔ F50=Line ports

Ⓕ F13=Drive shaft

Ⓖ S3=Front cover

Ⓗ Rotation

R=CW

L=CCW

Ⓘ Seal

F=FKM seal

Omit=NBR seal

Ⓙ Outboard bearing



O=Outboard bearing

Omit=Without outboard bearing

Ⓚ Option

V=Relief valve

D=Check valve

Ⓔ Line ports Inlet/Outlet		Ⓕ Drive shaft		Ⓖ Front cover	
F50	25.2 x 25.2, M6, Ø14.5 25.2 x 25.2, M6, Ø14.5 	F13	Flat keyed shaft Ø12.5mm x 31.8 	S3	4-hole mounting 63.5 x 63.5mm 

**1.5PF\*\*F\*\*F13S3\***

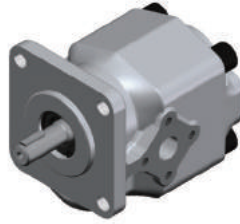

Model	Displacement (ml/r)	Pressure(bar)		Speed(r/min)		
		Rated	Peak	Rated	Max.	Min.
1.5PF02F50F13S3*	2	210	250	2000	3500	600
1.5PF03F50F13S3*	3	210	250	2000	3500	600
1.5PF04F50F13S3*	4	210	250	2000	3500	600
1.5PF05F50F13S3*	5	210	250	2000	3500	600
1.5PF06F50F13S3*	6	210	250	2000	3500	600
1.5PF08F50F13S3*	8	210	250	2000	3500	600
1.5PF09F50F13S3*	9	175	210	1500	2000	600
1.5PF11F50F13S3*	11	175	210	1500	2000	600
1.5PF12F50F13S3*	12	175	210	1500	2000	600

**Dimensions**

**1.5PF\*\*F50F13S3\***

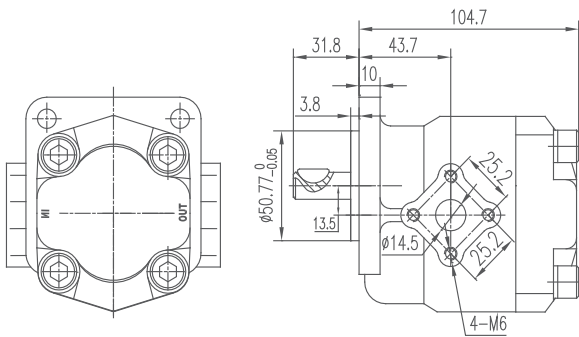

**Option: with relief valve**

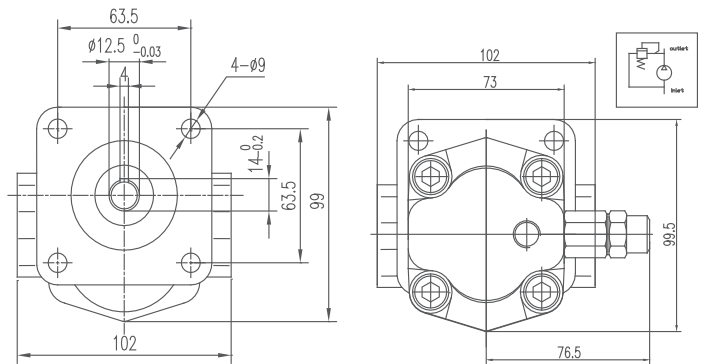



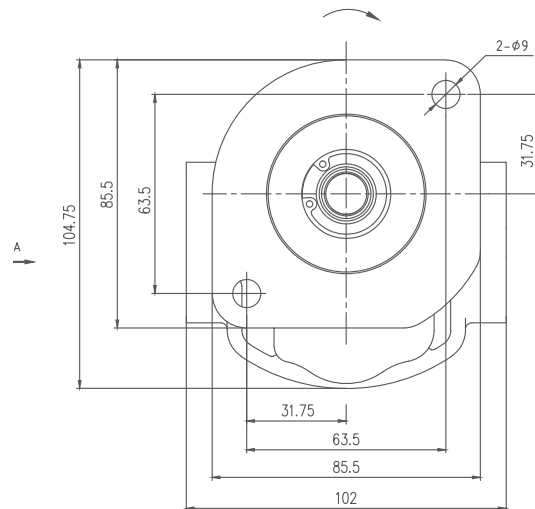
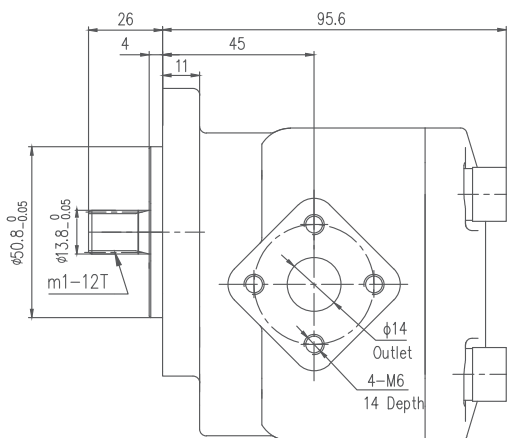















**1.5CPF\*\*FL60S92SP7\***



## Ordering Code

<b>2</b>	<b>*</b>	<b>P</b>	<b>F</b>	<b>18</b>	<b>L01</b>	<b>F32</b>	<b>D9</b>	<b>L-</b>	<b>SS</b>	<b>F-</b>	<b>O</b>	<b>-V</b>
a	b	c	d	e	f	g	h	i	j	k	l	m

- (a) 2=Group 2  
 (b) Improved number  
 Omit=Aluminum covers and body  
 A=Cast iron cover  
 AB=Low noise  
 L=Ultra-low noise  
 (c) P=Gear pump  
 (d) Pressure rate  
 E=160bar  
 F=200bar  
 G=250bar  
 (e) Displacement(ml/r)  
 4, 6, 8, 10, 12, 14, 16, 18, 20, 23, 25, 28, 30  
 (f) L01=Line ports  
 (g) F32=Drive shaft  
 (h) O8=Front cover  
 (i) Rotation  
 R=CW  
 L=CCW  
 B=Bi-directional  
 (j) Ports combination  
 SS=Side inlet and side outlet  
 SB=Side inlet and back outlet  
 BS=Back inlet and side outlet  
 BB=Back inlet and back outlet  
 (k) Seal F=FKM seal Omit=NBR seal  
 (l) Outboard bearing  
 O=Outboard bearing  
 Omit=Without outboard bearing  
 (m) Option V=Relief valve D=Check valve

(f) Line ports Inlet/Outlet			(g) Drive shaft			(h) Front cover		
L01	G3/8 Ø9 x 12.7 x 1.45mm		F32	Flat keyed shaft SAE A Ø15.88mm		O8	2-through hole mounting 60 x 60mm	
L46	G3/8 G3/8		T24	Tapered key shaft 1:8		S7	4-hole mounting 71.5 x 96.2mm	
L04	G1/2 G1/2		T10	Tapered key shaft 1:5		S8	4-hole mounting 72 x 100mm	
L05	G1/2 G3/8		D4	DIN spline shaft Ø12.7mm x 26mm		D9	2-groove mounting Ø106mm	
L69	G3/4 G3/4					D10	2-hole mounting Ø106mm	
L03	G1 G3/4							
LJ36	7/8-14UNF-2B 7/8-14UNF-2B							
LJ39	1-1/16-12UN-2B 7/8-14UNF-2B							
F02	Ø30, M6, Ø13 Ø30, M6, Ø13							
F52	Ø40, M6, Ø20 Ø35, M6, Ø15							

**2PF\*\*L\*\*F32D9\***



Model	Displacement (ml/r)	Pressure(bar)		Speed(r/min)			L (mm)	L1 (mm)	Inlet	Outlet
		Rated	Peak	Rated	Max.	Min.				
2PF4L09F32D9*	4	200	250	2000	3500	500	96	43.3	PT1/2	PT1/2
2PF6L09F32D9*	6	200	250	2000	3500	500	98	45		
2PF8L09F32D9*	8	200	250	2000	3500	500	102	46.5		
2PF10L09F32D9*	10	200	250	2000	3500	500	104	48		
2PF12L10F32D9*	12	200	250	2000	3500	500	108	50		
2PF14L10F32D9*	14	200	250	2000	3500	500	110	51	PT3/4	PT1/2
2PF16L10F32D9*	16	200	250	2000	3500	500	114	53		
2PF18L10F32D9*	18	200	250	2000	3500	500	117	55		
2PF20L10F32D9*	20	200	250	2000	3500	500	120	56		
2PF23L10F32D9*	23	200	250	2000	3000	500	123	58		
2PF25L10F32D9*	25	200	250	2000	3000	500	128	60		
2PF28L10F32D9*	28	160	200	2000	3000	500	133	63		
2PF30L10F32D9*	30	160	200	2000	3000	500	136	64		

**Dimensions**

**2PF\*\*L\*\*F32D9\***

**Option: Rear Oil Port**

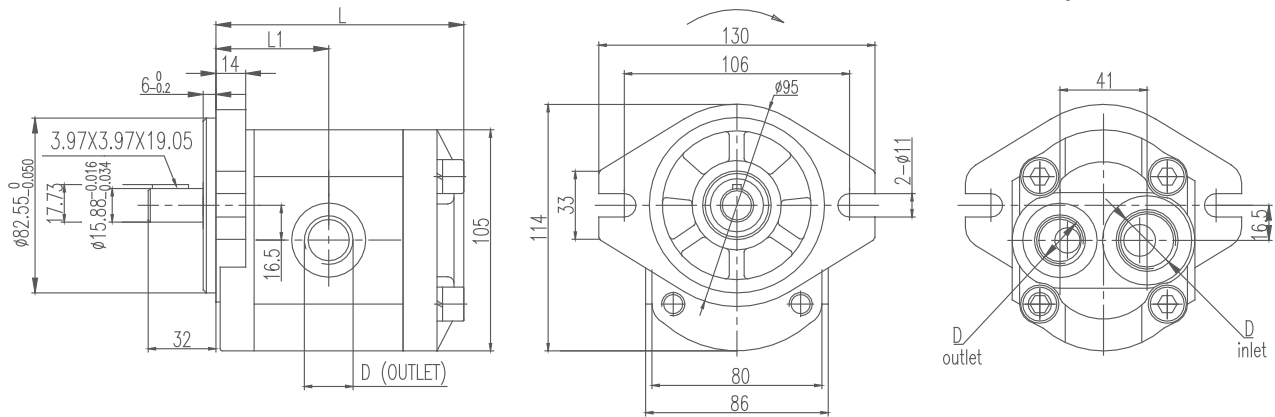

**2PF\*\*L\*\*S13D9-V**

**Option: With Relief Valve**

**Adjustable Pressure of Relief Valve 50~250 Bar**

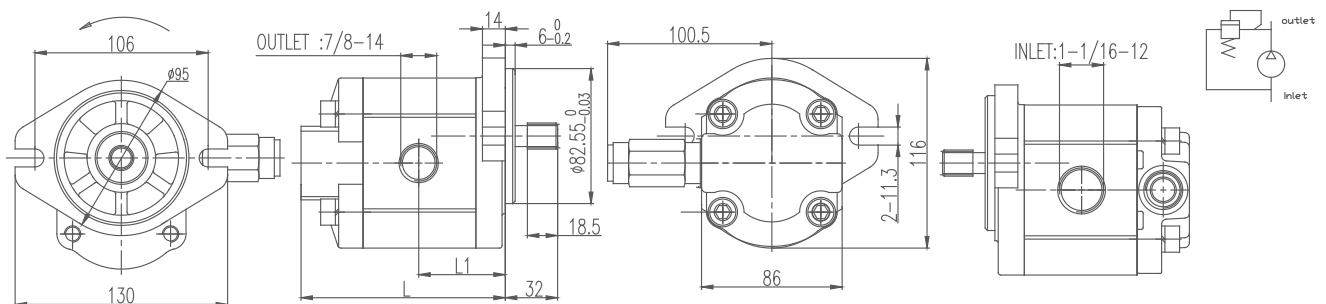



**2ABPF\*\*F\*\*T24S7\***

Model	Displacement (ml/r)	Pressure(bar)		Speed(r/min)			L (mm)	L1 (mm)	Inlet			Outlet			
		Rated	Peak	Rated	Max.	Min.			ØD1	Ød1	T1	ØD2	Ød2	T2	
2ABPF4F02T24S7*	4	200	250	2000	3500	500	95.5	43.3	30	13	M6				
2ABPF6F02T24S7*	6	200	250	2000	3500	500	99	45							
2ABPF8F02T24S7*	8	200	250	2000	3500	500	102	46.5							
2ABPF10F06T24S7*	10	200	250	2000	3500	500	105	48							
2ABPF12F06T24S7*	12	200	250	2000	3500	500	108	49.5							
2ABPF14F06T24S7*	14	200	250	2000	3500	500	111	51							
2ABPF16F06T24S7*	16	200	250	2000	3500	500	114	52.5	40	20	M8	3	13	M6	
2ABPF18F06T24S7*	18	200	250	2000	3500	500	117.5	54.3							
2ABPF20F06T24S7*	20	200	250	2000	3500	500	121	56							
2ABPF23F06T24S7*	23	200	250	2000	3000	500	125.5	58.3							
2ABPF25F06T24S7*	25	200	250	2000	3000	500	128	59.5							
2ABPF28F06T24S7*	28	160	200	2000	3000	500	133	62							
2ABPF30F06T24S7*	30	160	200	2000	3000	500	136	63.5							

**Dimensions****2ABPF\*\*F06T24S7\***

Option: With Relief Valve

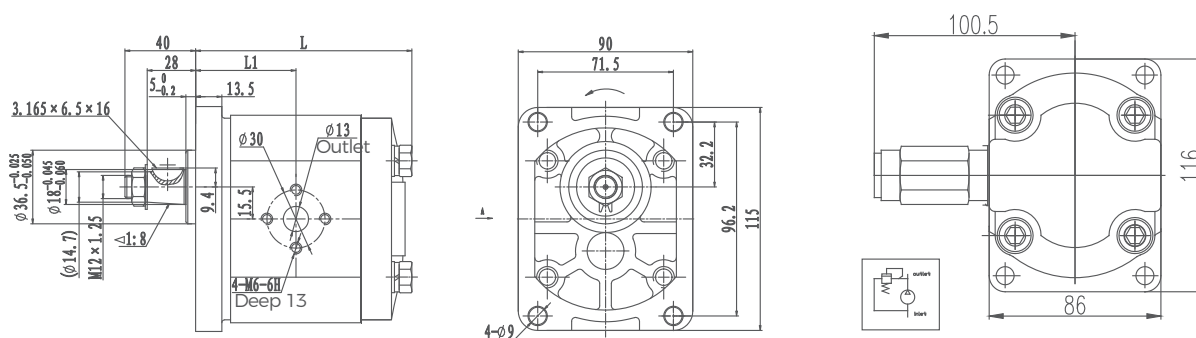
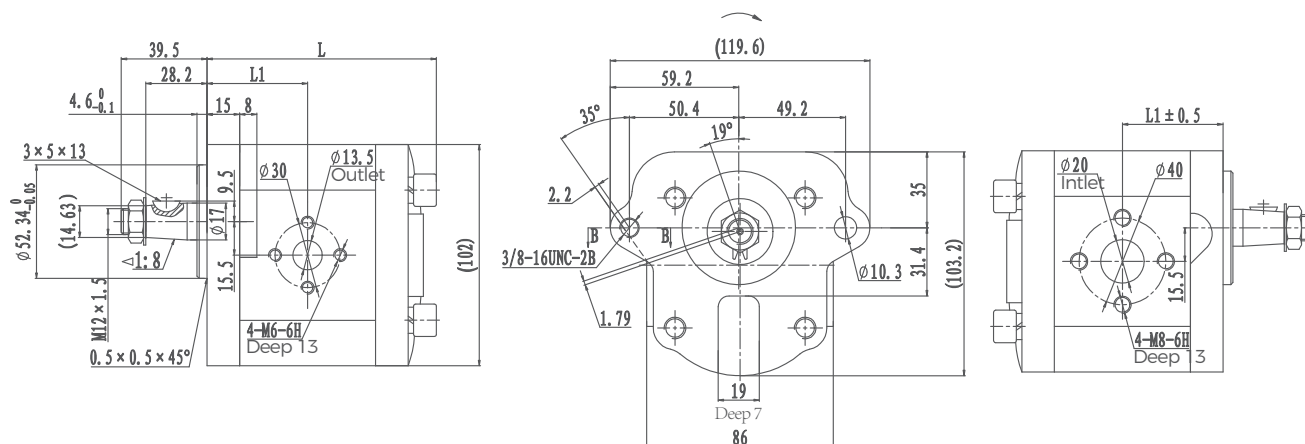
**2ABPF\*\*T49SP8L**

**2ABPF\*\*LJ\*\*S13D10L**



Model	Displacement (ml/r)	Pressure(bar)		Speed(r/min)			L1 (mm)	L (mm)	Inlet	Outlet
		Rated	Peak	Rated	Peak	Min.				
2ABPF04LJ37S13D10L	4	200	250	2000	3500	500	43.4	89.8	1-5/16-12UN	3/4-16UNF
2ABPF5.6LJ37S13D10L	5.6	200	250	2000	3500	500	45.3	93.5		
2ABPF06LJ37S13D10L	6	200	250	2000	3500	500	46.8	96.5		
2ABPF08LJ37S13D10L	8	200	250	2000	3500	500	48.5	100.0		
2ABPF10LJ37S13D10L	10	200	250	2000	3500	500	49.4	101.7		
2ABPF12LJ37S13D10L	12	200	250	2000	3500	500	50.3	103.5		
2ABPF14LJ37S13D10L	14	200	250	2000	3500	500	51.8	106.5		
2ABPF16LJ37S13D10L	16	200	250	2000	3500	500	53.5	110.0		
2ABPF18LJ37S13D10L	18	200	250	2000	3500	500	55.3	113.5		
2ABPF20LJ37S13D10L	20	200	250	2000	3500	500	57.0	117.0		
2ABPF23LJ37S13D10L	23	200	250	2000	3000	500	59.3	121.5		
2ABPF25LJ37S13D10L	25	160	200	2000	3000	500	61.0	125.0		
2ABPF28LJ37S13D10L	28	160	200	2000	3000	500	63.5	130.0		
2ABPF30LJ37S13D10L	30	160	200	2000	3000	500	65.0	133.0		

**Dimensions**

**2ABPF\*\*LJ37S13D10L**

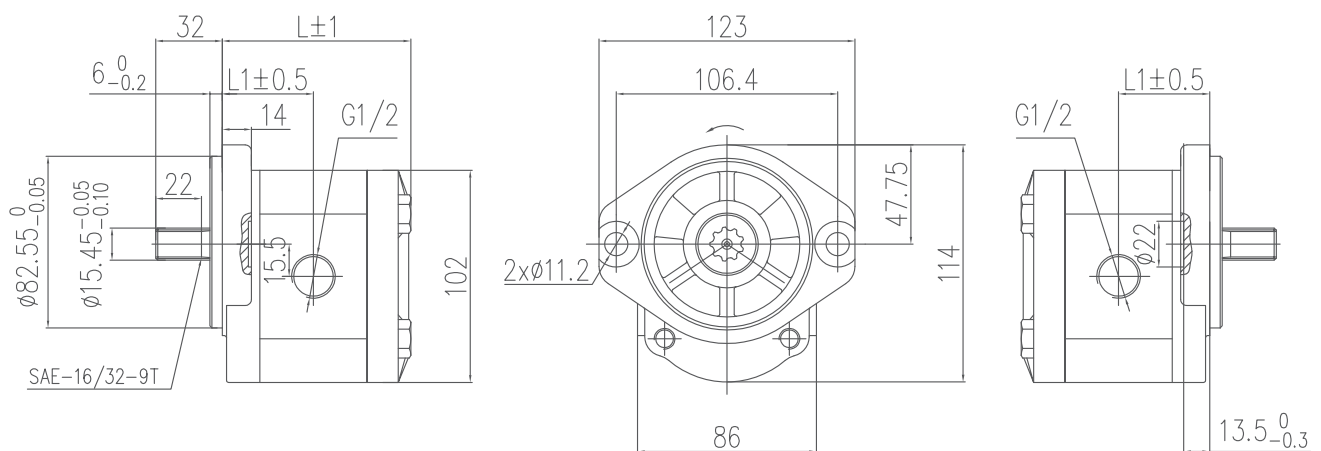

## 2ABPF\*\*L\*\*S13D10-TLT-O

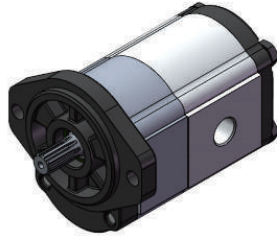

Model	Displacement (ml/r)	Pressure(bar)		Speed(r/min)			L1 (mm)	L (mm)	Inlet	Outlet
		Rated	Max.	Rated	Max.	Min.				
2ABPF04L08S13D10-TLT-O	4	200	250	2000	3500	500	87.4	133.8	G3/4	G1/2
2ABPF06L08S13D10-TLT-O	6	200	250	2000	3500	500	89.3	137.5		
2ABPF08L08S13D10-TLT-O	8	200	250	2000	3500	500	90.8	140.5		
2ABPF10L08S13D10-TLT-O	10	200	250	2000	3500	500	92.5	144.0		
2ABPF12L08S13D10-TLT-O	12	200	250	2000	3500	500	94.3	147.5		
2ABPF14L08S13D10-TLT-O	14	200	250	2000	3500	500	95.8	150.5		
2ABPF16L08S13D10-TLT-O	16	200	250	2000	3500	500	97.5	154.0		
2ABPF18L08S13D10-TLT-O	18	200	250	2000	3500	500	99.3	157.5		
2ABPF20L08S13D10-TLT-O	20	200	250	2000	3500	500	101.0	161.0		
2ABPF23L08S13D10-TLT-O	23	200	250	2000	3000	500	103.3	165.5		
2ABPF25L08S13D10-TLT-O	25	160	200	2000	3000	500	105.0	169.0		
2ABPF28L08S13D10-TLT-O	28	160	200	2000	3000	500	107.5	174.0		
2ABPF30L08S13D10-TLT-O	30	160	200	2000	3000	500	109.0	177.0		

## Dimensions

### 2ABPF\*\*L08S13D10-TLT-O

-TLT is special rear cover structure

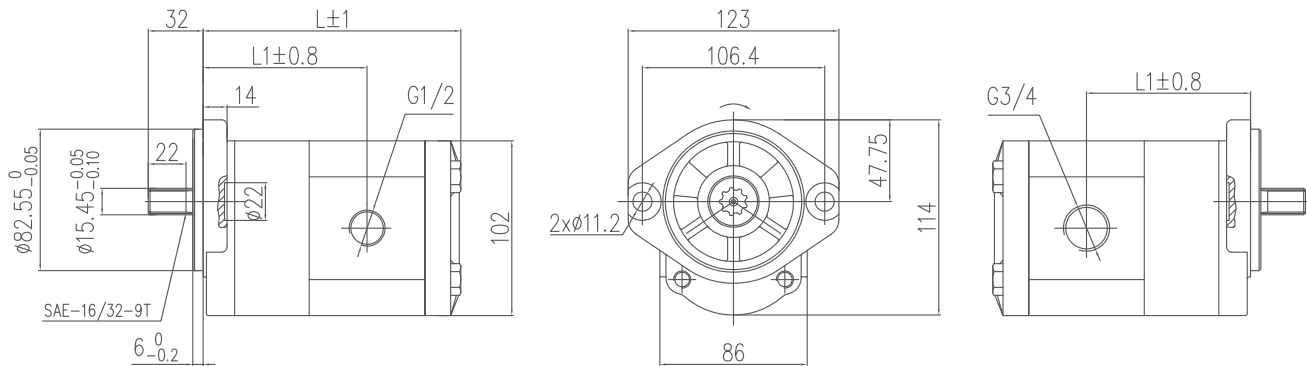

## 2ABPF\*\*L\*\*S13D10-TLT

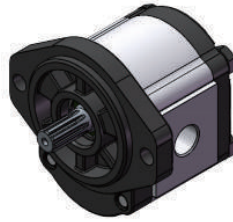

Model	Displacement (ml/r)	Pressure(bar)		Speed(r/min)			L1 (mm)	L (mm)	Inlet	Outlet
		Rated	Max.	Rated	Max.	Min.				
2ABPF04L04S13D10-TLT	4	200	250	2000	3500	500	43.4	89.8	G1/2	G1/2
2ABPF4.5L04S13D10-TLT	4.5	200	250	2000	3500	500	43.8	90.6		
2ABPF06L04S13D10-TLT	6	200	250	2000	3500	500	45.3	93.5		
2ABPF08L04S13D10-TLT	8	200	250	2000	3500	500	46.8	96.5		
2ABPF10L04S13D10-TLT	10	200	250	2000	3500	500	48.5	100.0		
2ABPF12L04S13D10-TLT	12	200	250	2000	3500	500	50.3	103.5		
2ABPF14L04S13D10-TLT	14	200	250	2000	3500	500	51.8	106.5		
2ABPF16L04S13D10-TLT	16	200	250	2000	3500	500	53.5	110.0		
2ABPF18L04S13D10-TLT	18	200	250	2000	3500	500	55.3	113.5		
2ABPF20L04S13D10-TLT	20	200	250	2000	3500	500	57.0	117.0		
2ABPF23L04S13D10-TLT	23	200	250	2000	3000	500	59.3	121.5		
2ABPF25L04S13D10-TLT	25	160	200	2000	3000	500	61.0	125.0		
2ABPF28L04S13D10-TLT	28	160	200	2000	3000	500	63.5	130.0		
2ABPF30L04S13D10-TLT	30	160	200	2000	3000	500	65.0	133.0		

### Dimensions

#### 2ABPF\*\*L04S13D10L-TLT

-TLT is special rear cover structure

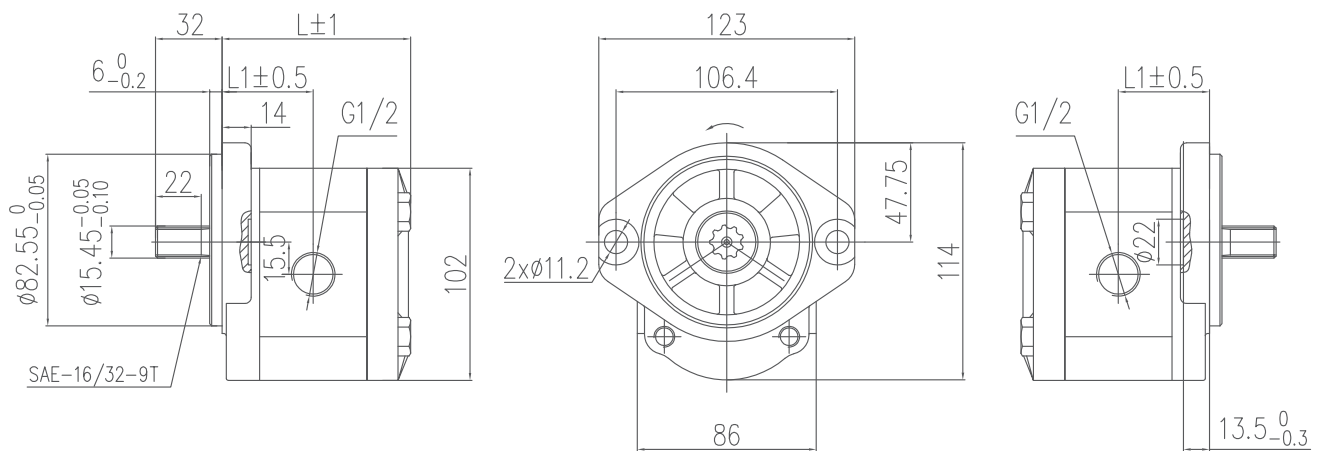

## 2ABPF\*\*LJ\*\*S13D10-TLT-D



Model	Displacement (ml/r)	Pressure(bar)		Speed(r/min)			L1 (mm)	L (mm)	Inlet	Outlet
		Rated	Max.	Rated	Max.	Min.				
2ABPF04LJ37S13D10-TLT-D	4.0	200	250	2000	3500	500	43.4	89.8	7/8-14UNF	3/4-16UNF
2ABPF5.6LJ37S13D10-TLT-D	5.6	200	250	2000	3500	500	44.8	92.5		
2ABPF06LJ37S13D10-TLT-D	6.0	200	250	2000	3500	500	45.3	93.5		
2ABPF08LJ37S13D10-TLT-D	8.0	200	250	2000	3500	500	46.8	96.5		
2ABPF10LJ37S13D10-TLT-D	10.0	200	250	2000	3500	500	48.5	100.0		
2ABPF12LJ37S13D10-TLT-D	12.0	200	250	2000	3500	500	50.3	103.5		
2ABPF14LJ37S13D10-TLT-D	14.0	200	250	2000	3500	500	51.8	106.5		
2ABPF16LJ37S13D10-TLT-D	16.0	200	250	2000	3500	500	53.5	110.0		
2ABPF18LJ37S13D10-TLT-D	18.0	200	250	2000	3500	500	55.3	113.5		
2ABPF20LJ37S13D10-TLT-D	20.0	200	250	2000	3500	500	57.0	117.0		
2ABPF23LJ37S13D10-TLT-D	23.0	200	250	2000	3000	500	59.3	121.5		
2ABPF25LJ37S13D10-TLT-D	25.0	160	200	2000	3000	500	61.0	125.0		
2ABPF28LJ37S13D10-TLT-D	28.0	160	200	2000	3000	500	63.5	130.0		
2ABPF30LJ37S13D10-TLT-D	30.0	160	200	2000	3000	500	65.0	133.0		

## Dimensions

### 2ABPF\*\*LJ37S13D10L-TLT-D

-TLT is special rear cover structure  
 -D is galvanized surface of front and rear cover cast iron parts

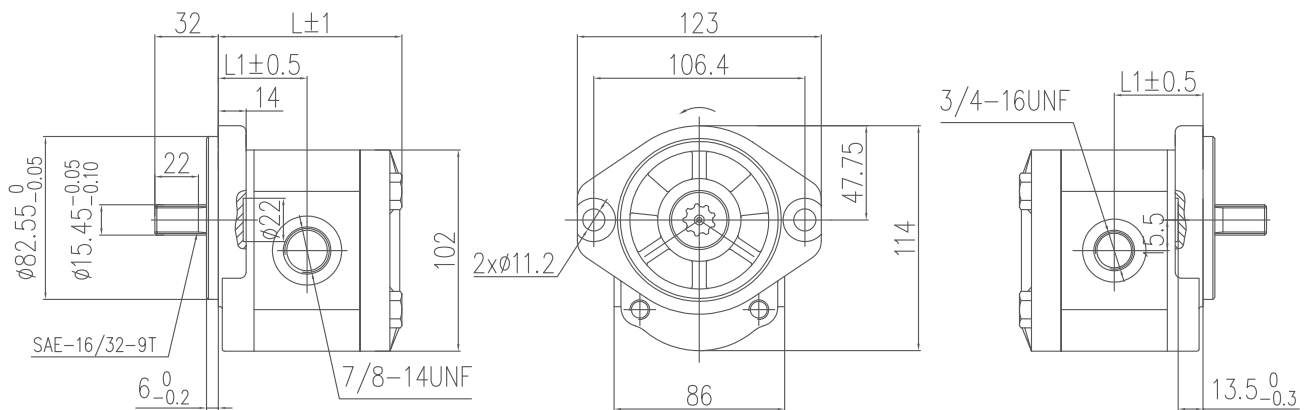

**2ABPF\*\*LJ\*\*S46D9-W-D-TLT**



Model	Displacement (ml/r)	Pressure(bar)		Speed(r/min)			L1 (mm)	L (mm)	Inlet	Outlet
		Rated	Max.	Rated	Max.	Min.				
2ABPF04LJ90S46D9-W-D-TLT	4	200	250	2000	3500	500	43.4	89.8	1-5/16-12UN	3/4-16UNF
2ABPF06LJ90S46D9-W-D-TLT	6	200	250	2000	3500	500	45.3	93.5		
2ABPF08LJ90S46D9-W-D-TLT	8	200	250	2000	3500	500	46.8	96.5		
2ABPF10LJ90S46D9-W-D-TLT	10	200	250	2000	3500	500	48.5	100.0		
2ABPF11LJ90S46D9-W-D-TLT	11	200	250	2000	3500	500	49.4	101.7		
2ABPF12LJ90S46D9-W-D-TLT	12	200	250	2000	3500	500	50.3	103.5		
2ABPF14LJ90S46D9-W-D-TLT	14	200	250	2000	3500	500	51.8	106.5		
2ABPF16LJ90S46D9-W-D-TLT	16	200	250	2000	3500	500	53.5	110.0		
2ABPF18LJ90S46D9-W-D-TLT	18	200	250	2000	3500	500	55.3	113.5		
2ABPF20LJ90S46D9-W-D-TLT	20	200	250	2000	3500	500	57.0	117.0		
2ABPF23LJ90S46D9-W-D-TLT	23	200	250	2000	3000	500	59.3	121.5		
2ABPF25LJ90S46D9-W-D-TLT	25	160	200	2000	3000	500	61.0	125.0		
2ABPF28LJ90S46D9-W-D-TLT	28	160	200	2000	3000	500	63.5	130.0		
2ABPF30LJ90S46D9-W-D-TLT	30	160	200	2000	3000	500	65.0	133.0		

**Dimensions**

**2ABPF\*\*LJ37S46D9L-W-D-TLT**

- TLT is special rear cover structure
- D is galvanized surface of front and rear cover cast iron parts

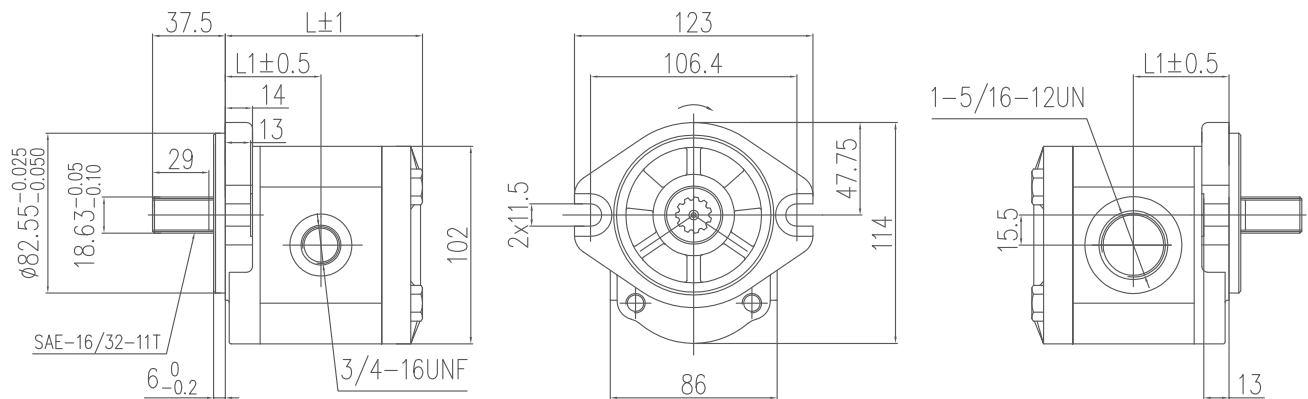

## 2LPF\*\*F\*\*T31S7\*



Model	Displacement (ml/r)	Pressure(bar)		Speed(r/min)			L(mm)	L1(mm)
		Rated	Peak	Rated	Max.	Min.		
2LPF04F52T31S7*	4	200	230	1500	1800	1000	95.5	42.0
2LPF06F52T31S7*	6	200	230	1500	1800	1000	99.0	43.8
2LPF08F52T31S7*	8	200	230	1500	1800	1000	103.0	45.8
2LPF10F52T31S7*	10	200	230	1500	1800	1000	107.0	47.8
2LPF12F52T31S7*	12	200	230	1500	1800	1000	111.0	49.8
2LPF14F52T31S7*	14	200	230	1500	1800	1000	115.0	51.8
2LPF16F52T31S7*	16	200	230	1500	1800	1000	118.5	53.5
2LPF18F52T31S7*	18	200	230	1500	1800	1000	122.5	55.5
2LPF19F52T31S7*	19	180	210	1500	1800	1000	124.5	56.5
2LPF20F52T31S7*	20	180	210	1500	1800	1000	126.5	57.5
2LPF23F52T31S7*	23	180	210	1500	1800	1000	132.5	60.5
2LPF25F52T31S7*	25	160	180	1500	1800	1000	136.0	62.3
2LPF28F52T31S7*	28	160	180	1500	1800	1000	142.0	65.3
2LPF30F52T31S7*	30	160	180	1500	1800	1000	146.0	67.3

## Dimensions

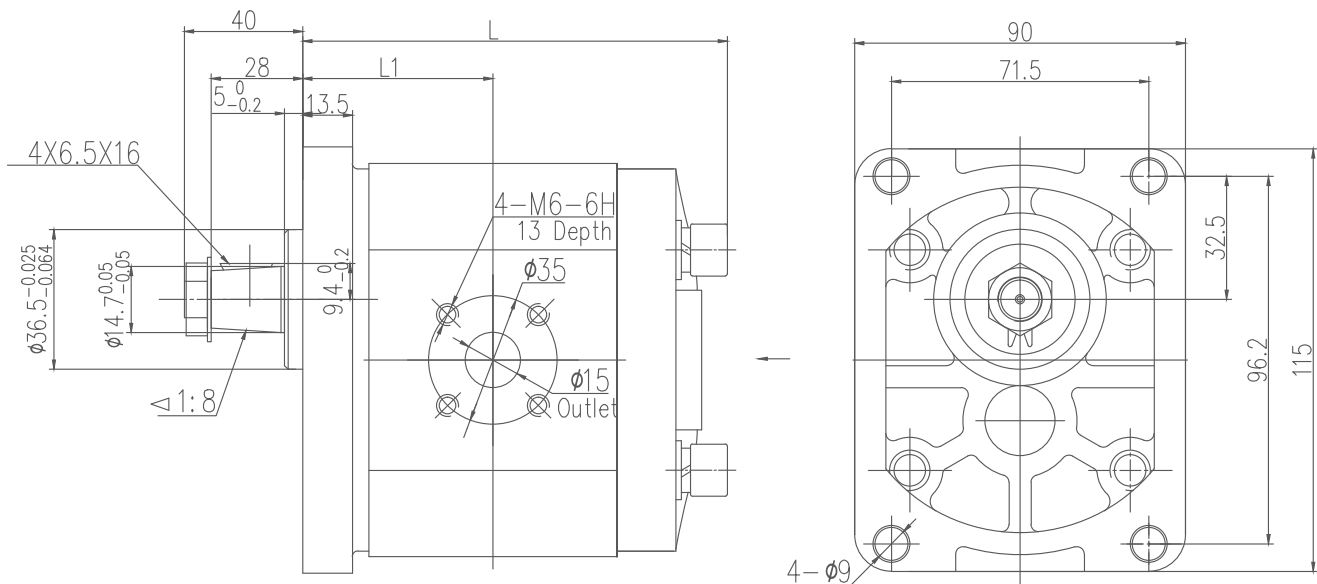

**2APF\*\*F\*\*T2008\***



Model	Displacement (ml/r)	Pressure(bar)		Speed(r/min)			L (mm)	L1 (mm)	Inlet			Outlet		
		Rated	Peak	Rated	Max.	Min.			ØD1	Ød1	T1	ØD2	Ød2	T2
2APF4F60T2008*	4	200	250	2000	3500	500	95.5	43.3	40	15	M6	35	15	M6
2APF6F60T2008*	6	200	250	2000	3500	500	99.0	45.0						
2APF8F52T2008*	8	200	250	2000	3500	500	102.0	46.5						
2APF10F52T2008*	10	200	250	2000	3500	500	105.0	48.0						
2APF12F52T2008*	12	200	250	2000	3500	500	108.0	49.5						
2APF14F52T2008*	14	200	250	2000	3500	500	111.0	51.0						
2APF16F52T2008*	16	200	250	2000	3500	500	114.0	52.5	40	20	M6	35	15	M6
2APF18F52T2008*	18	200	250	2000	3500	500	117.5	54.3						
2APF20F52T2008*	20	200	250	2000	3500	500	121.0	56.0						
2APF23F52T2008*	23	200	250	2000	3000	500	125.5	58.3						
2APF25F52T2008*	25	200	250	2000	3000	500	128.0	59.5						
2APF28F52T2008*	28	160	200	2000	3000	500	133.0	62.0						
2APF30F52T2008*	30	160	200	2000	3000	500	136.0	63.5						

**Dimensions**

**2APF\*\*F52T2008\***

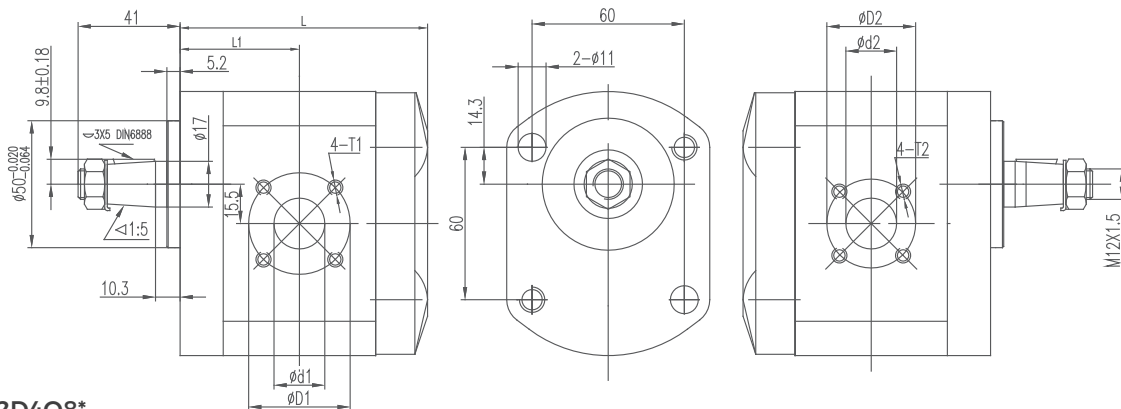

**2APF\*\*F52D408\***

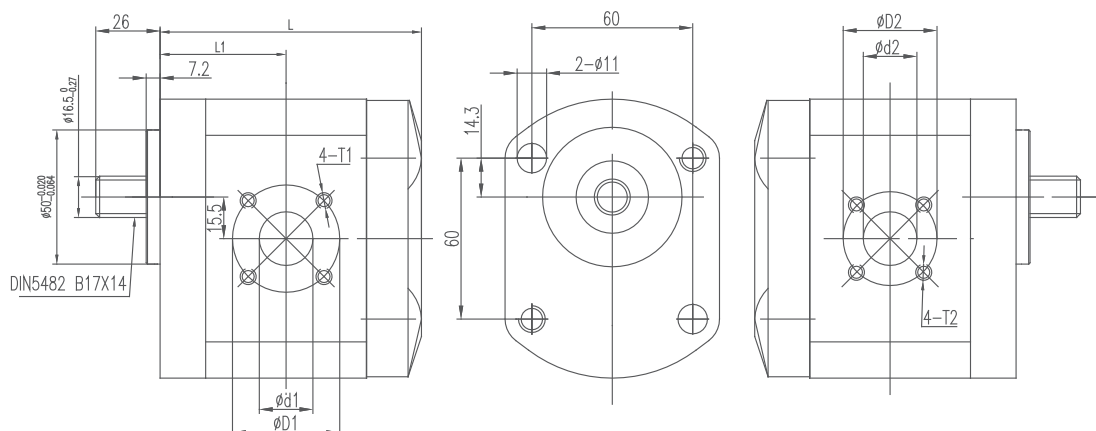



## 2APF\*\*F\*\*T21SP1\*



Model	Displacement (ml/r)	Pressure(bar)		Speed(r/min)			L (mm)	L1 (mm)	Inlet			Outlet
		Rated	Peak	Rated	Max.	Min.			ØD1	Ød1	T1	
2APF4LF5T21SP1*	4	200	250	2000	3500	500	91.5	42.3	40	19	M6	G3/8
2APF6LF5T21SP1*	6	200	250	2000	3500	500	95.0	44.0				
2APF8LF5T21SP1*	8	200	250	2000	3500	500	98.0	45.5				
2APF10LF5T21SP1*	10	200	250	2000	3500	500	101.0	47.0				
2APF12LF5T21SP1*	12	200	250	2000	3500	500	104.5	48.8				
2APF14LF5T21SP1*	14	200	250	2000	3500	500	107.5	50.0				
2APF16LF5T21SP1*	16	200	250	2000	3500	500	111.0	52.0				
2APF18LF5T21SP1*	18	200	250	2000	3500	500	114.0	54.0				
2APF20LF5T21SP1*	20	200	250	2000	3500	500	118.0	55.0				
2APF23LF5T21SP1*	23	200	250	2000	3500	500	122.0	58.0				
2APF25LF5T21SP1*	25	200	250	2000	3500	500	125.0	59.0				
2APF28LF5T21SP1*	28	160	200	2000	3500	500	130.0	61.0				
2APF30LF5T21SP1*	30	160	200	2000	3500	500	133.0	63.0				

## Dimensions

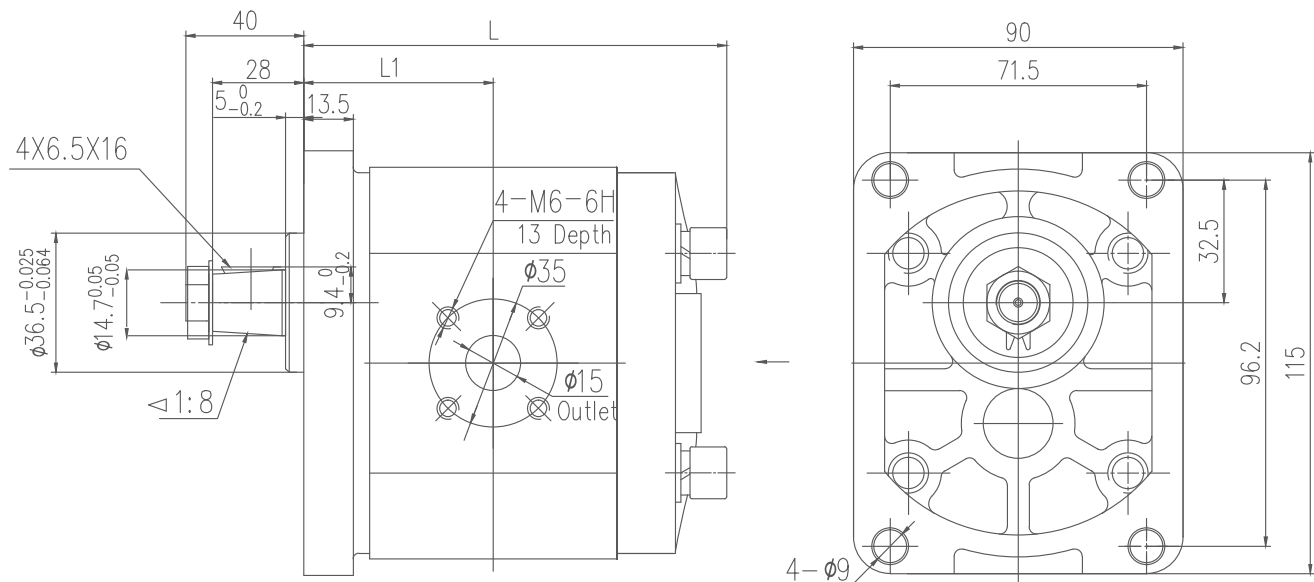

**2APF\*\*F\*\*T10S8\***



Model	Displacement (ml/r)	Pressure(bar)		Speed(r/min)			L (mm)	L1 (mm)	Inlet			Outlet		
		Rated	Peak	Rated	Max.	Min.			ØD1	Ød1	T1	ØD2	Ød2	T2
2APF4F60T10S8*	4	200	250	2000	3500	500	95.5	43.3	40	15	M6	35	15	M6
2APF6F60T10S8*	6	200	250	2000	3500	500	99.0	45.0						
2APF8F52T10S8*	8	200	250	2000	3500	500	102.0	46.5						
2APF10F52T10S8*	10	200	250	2000	3500	500	105.0	48.0						
2APF12F52T10S8*	12	200	250	2000	3500	500	108.0	49.5						
2APF14F52T10S8*	14	200	250	2000	3500	500	111.0	51.0						
2APF16F52T10S8*	16	200	250	2000	3500	500	114.0	52.5	40	20	M6	35	15	M6
2APF18F52T10S8*	18	200	250	2000	3500	500	117.5	54.3						
2APF20F52T10S8*	20	200	250	2000	3500	500	121.0	56.0						
2APF23F52T10S8*	23	200	250	2000	3000	500	125.5	58.3						
2APF25F52T10S8*	25	200	250	2000	3000	500	128.0	59.5						
2APF28F52T10S8*	28	160	200	2000	3000	500	133.0	62.0						
2APF30F52T10S8*	30	160	200	2000	3000	500	136.0	63.5						

**Dimensions**

**2APF\*\*F52T10S8\***

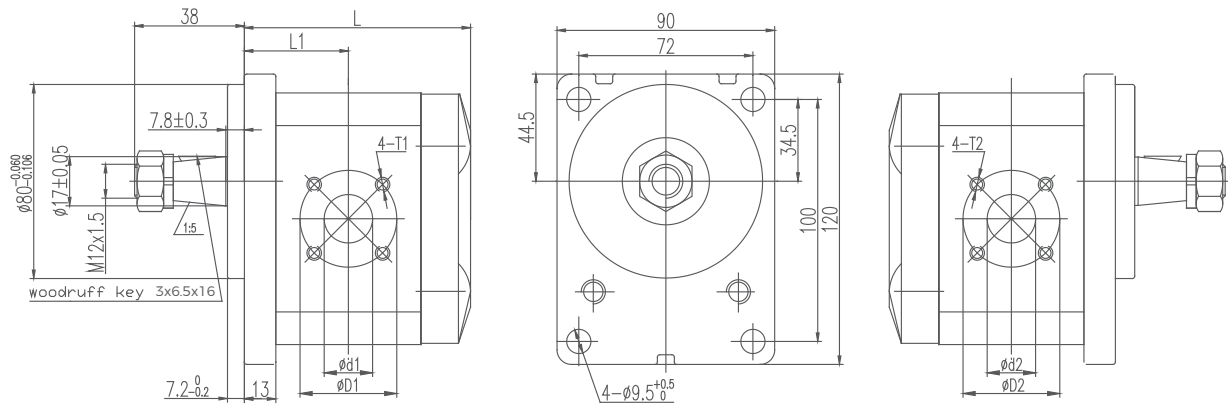

**2APF\*\*F52T37S9\***

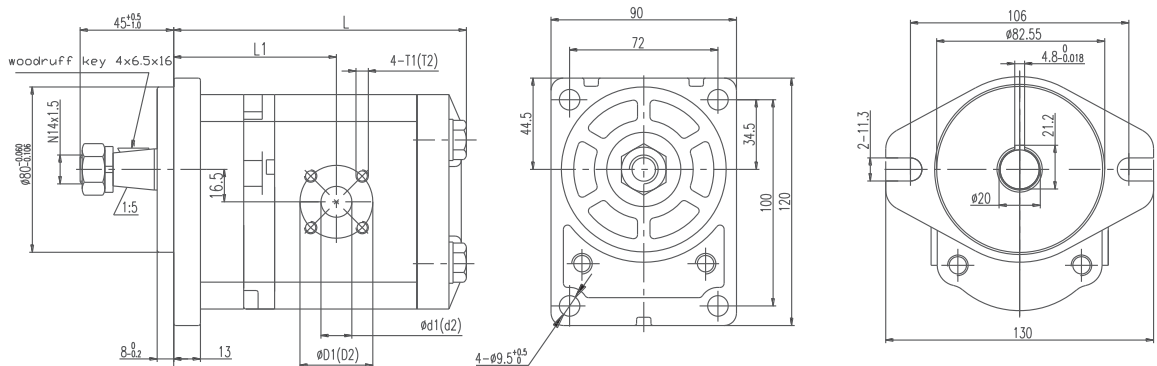















**Option: 2PF\*\*F\*\*P21\*-O**

## Ordering Code

<b>2.5</b>	<b>A</b>	<b>P</b>	<b>F</b>	<b>30</b>	<b>L04</b>	<b>F63</b>	<b>D9</b>	<b>L-</b>	<b>SS</b>	<b>F-</b>	<b>O</b>	<b>-V</b>
a	b	c	d	e	f	g	h	i	j	k	i	m

- (a) 2.5=Group 2.5  
 (b) Improved number  
     Omit=Aluminum cover and body  
     C=Forklift pump  
     Q=Ceramic forklift pump  
 (c) P=Gear pump  
 (d) Pressure rate  
     E=160bar  
     F=200bar  
     G=250bar  
 (e) Displacement(ml/r)  
     20, 25, 27, 30, 32, 36, 40  
 (f) L04=Line ports  
 (g) F63=Drive shaft  
 (h) D9=Front cover  
 (i) Rotation  
     R=CW  
     L=CCW  
     B=Bi-directional  
 (j) Ports combination  
     SS=Side inlet and side outlet  
     SB=Side inlet and back outlet  
     BS=Back inlet and side outlet  
     BB=Back inlet and back outlet  
 (k) Seal  
     F=FKM seal  
     Omit=NBR seal  
 (l) Outboard bearing  
     O=Outboard bearing  
     Omit=Without outboard bearing  
 (m) Option  
     V=Relief valve  
     D=Check valve

(f) Line ports Inlet/Outlet			(g) Drive shaft			(h) Front cover		
L04	G1/2 G1/2		F63	Flat keyed shaft SAE A Ø15.88mm		D9	2-groove mounting Ø106mm	
L69	G3/4 G3/4		T24	Tapered key shaft 1:8		SP9	2-groove mounting Ø106mm	
L03	G1 G3/4		T10	Tapered key shaft 1:5				
LJ36	7/8-14UNF-2B 7/8-14UNF-2B		S46	Splined shaft 11 teeth 18.63mm				
LJ39	1-1/16-12UN-2B 7/8-14UNF-2B		S28	Splined shaft 10 teeth 16.95mm				
F30	52.4 x 26.2, M10, Ø25 47.6 x 22.2, M10, Ø19							
F77	30.2 x 58.7, M10, Ø25 26.2 x 52.4, M10, Ø19							

**2.5APF \*\*L\*\*F63D9\***

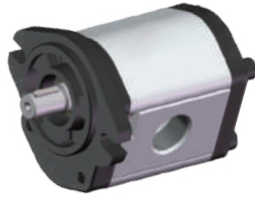

Model	Displacement (ml/r)	Pressure(bar)		Speed(r/min)			L (mm)	L1 (mm)	Inlet	Outlet
		Rated	Peak	Rated	Max.	Min.				
2.5APF20L03F63D9*	20	200	250	2000	3000	500	124.5	61.5	G1	G3/4
2.5APF25L03F63D9*	25	200	250	2000	3000	500	130.5	64.5		
2.5APF27L03F63D9*	27	200	250	2000	3000	500	133.0	65.8		
2.5APF30L03F63D9*	30	200	250	2000	3000	500	136.5	67.5		
2.5APF32L03F63D9*	32	200	230	2000	3000	500	139.0	68.8		
2.5APF36L03F63D9*	36	200	230	2000	3000	500	143.5	71.0		
2.5APF40L03F63D9*	40	160	200	2000	3000	500	148.5	73.5		

**Dimensions**

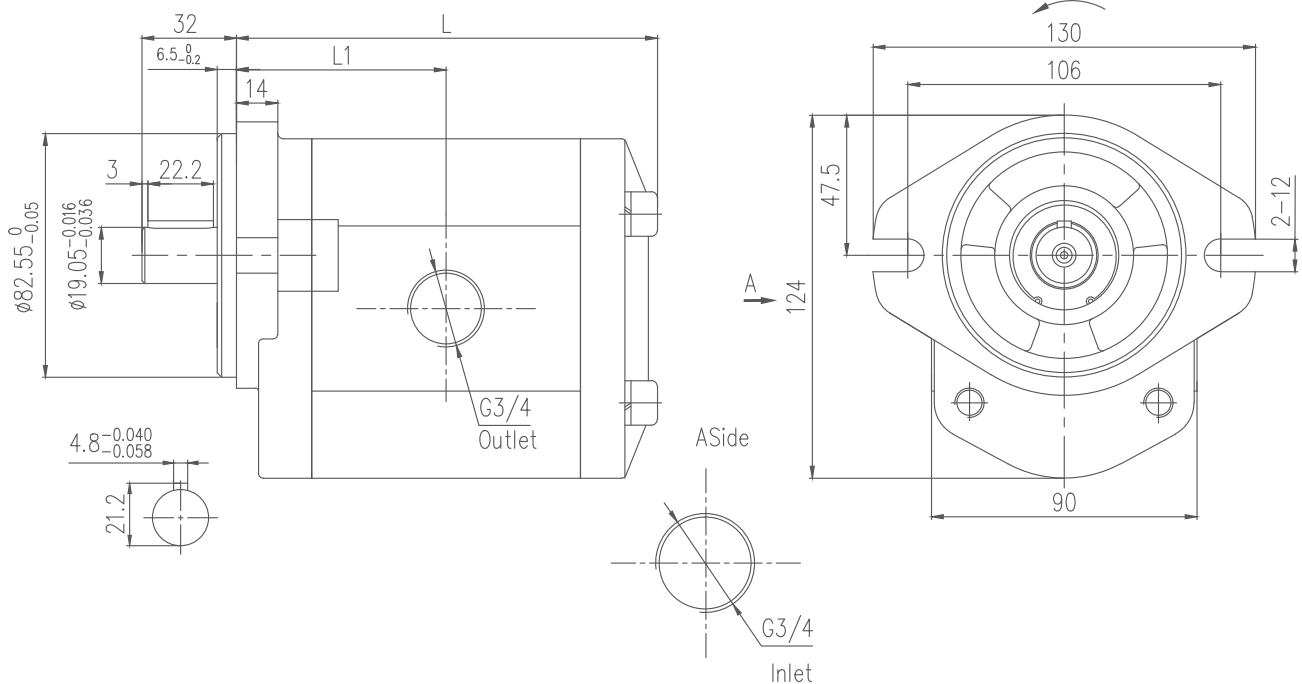

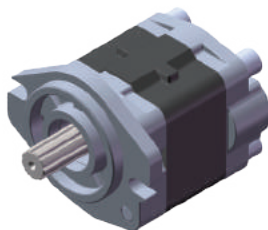
**2.5CPF \*\*F\*\*S28SP9\***

Model	Displacement (ml/r)	Pressure(bar)		Speed(r/min)			L (mm)	L1 (mm)	Inlet	Outlet
		Rated	Peak	Rated	Max.	Min.				
2.5CPF20F30S28SP9*	20	200	250	2000	3000	500	124.5	61.5	Ø25	Ø19
2.5CPF25F30S28SP9*	25	200	250	2000	3000	500	130.5	64.5		
2.5CPF27F30S28SP9*	27	200	250	2000	3000	500	133.0	65.8		
2.5CPF30F30S28SP9*	30	200	250	2000	3000	500	136.5	67.5		
2.5CPF32F30S28SP9*	32	200	230	2000	3000	500	139.0	68.8		
2.5CPF36F30S28SP9*	36	200	230	2000	3000	500	143.5	71.0		
2.5CPF40F30S28SP9*	40	160	200	2000	3000	500	148.5	73.5		

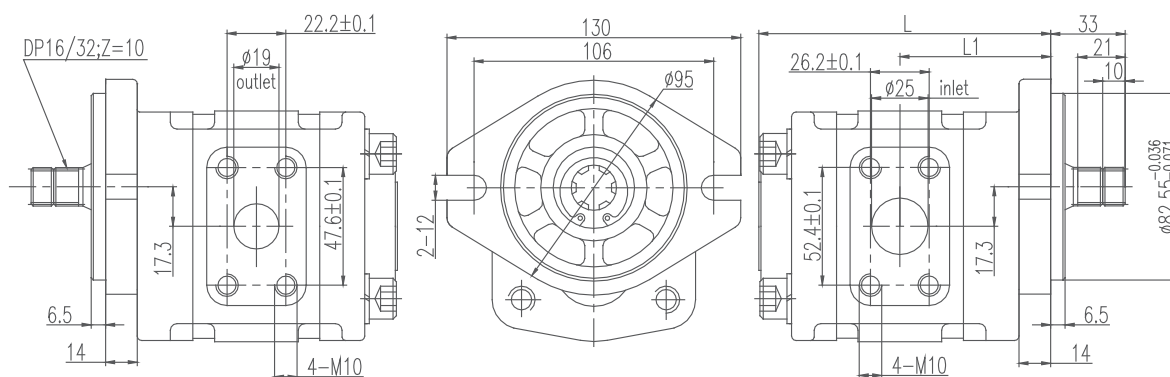
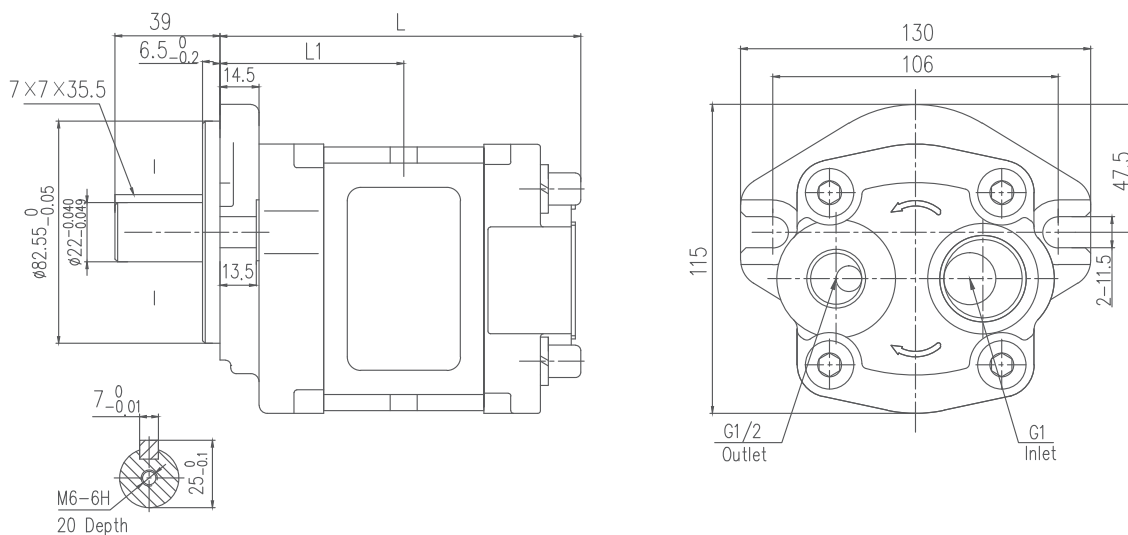
**Dimensions****2.5CPF\*\*F30S28SP9\*****2.5CPF\*\*LJ03F88SP9LBB****Option : 2.5CPF\*\*LJ02S28SP9\*BB**

## 2.5QPF \*\*LJ03S65SP9LBB

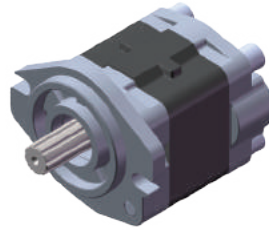

Model	Displacement (ml/r)	Pressure(bar)		Speed(r/min)			L (mm)	Inlet	Outlet
		Rated	Peak	Rated	Max.	Min.			
2.5QPF16LJ03S65SP9LBB	16	200	250	1500	2500	500	101.5	G1	G3/4
2.5QPF18LJ03S65SP9LBB	18	200	250	1500	2500	500	103.5		
2.5QPF20LJ03S65SP9LBB	20	200	250	1500	2500	500	105.5		
2.5QPF23LJ03S65SP9LBB	23	200	250	1500	2500	500	108.5		
2.5QPF25LJ03S65SP9LBB	25	200	250	1500	2500	500	110.5		
2.5QPF28LJ03S65SP9LBB	28	200	250	1500	2500	500	113.5		
2.5QPF30LJ03S65SP9LBB	30	200	250	1500	2500	500	115.5		
2.5QPF32LJ03S65SP9LBB	32	200	250	1500	2500	500	117.5		
2.5QPF36LJ03S65SP9LBB	36	200	250	1500	2500	500	121.5		
2.5QPF40LJ03S65SP9LBB	40	200	250	1500	2500	500	125.5		
2.5QPF45LJ03S65SP9LBB	45	200	250	1500	2500	500	130.5		
2.5QPF52LJ03S65SP9LBB	52	200	250	1500	2500	500	137.5		

## Dimensions

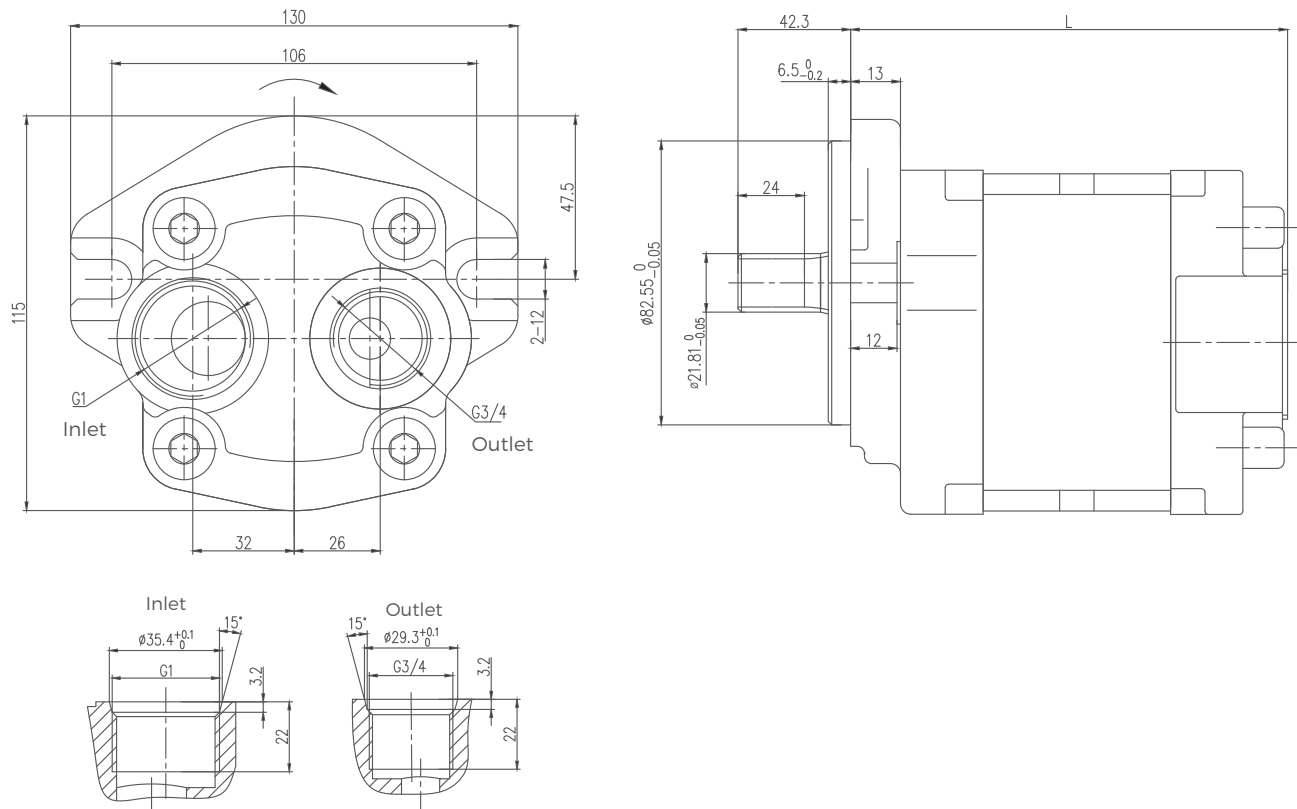

## Ordering Code

<b>2.8</b>	<b>A</b>	<b>P</b>	<b>F</b>	<b>40</b>	<b>L69</b>	<b>S71</b>	<b>D16</b>	<b>L-</b>	<b>SS</b>	<b>F-</b>	<b>O</b>	<b>-V</b>
a	b	c	d	e	f	g	h	i	j	k	i	m

- Ⓐ 2.8=Group 2.8  
 Ⓑ Improved number  
 A=Cast iron cover  
 X= High performance

Ⓒ P=Gear pump

Ⓓ Pressure rate

E=160bar

F=200bar

G=250bar

Ⓔ Displacement(ml/r)

6, 8, 10, 12, 14, 16, 19, 22, 25,

28, 30, 32, 36, 40, 43, 45

Ⓕ L69=Line ports

Ⓖ S71=Drive shaft

Ⓗ D16=Front cover

Ⓘ Rotation

R=CW

L=CCW

B=Bi-directional

⓷ Ports combination

Ⓚ Seal

F=FKM seal

Omit=NBR seal

Ⓛ Outboard bearing









O=Outboard bearing

Omit=Without outboard bearing

Ⓜ Option

V=Relief valve

D=Check valve

Ⓕ Line ports Inlet/Outlet			Ⓖ Drive shaft		Ⓗ Front cover	
L04	G1/2 G1/2		S71	Splined shaft 13 teeth 21.81mm 	D16	2-hole mounting Ø146mm 
L05	G1/2 G3/8					
L69	G3/4 G3/4					
L03	G1 G3/4					
LJ36	7/8-14UNF-2B 7/8-14UNF-2B					
LJ39	1-1/16-12UN-2B 7/8-14UNF-2B					

## 2.8APF\*\*LJ\*\*S71D16L



Model	Displacement (ml/r)	Pressure(bar)		Speed(r/min)			L(mm)
		Rated	Peak	Rated	Max.	Min.	
2.8APF06LJ39S71D16L	06	250	280	2000	4000	800	115.0
2.8APF08LJ39S71D16L	08	250	280	2000	4000	800	117.0
2.8APF10LJ39S71D16L	10	250	280	2000	4000	700	119.0
2.8APF12LJ39S71D16L	12	250	280	2000	3500	700	121.5
2.8APF14LJ39S71D16L	14	250	280	2000	3500	600	123.5
2.8APF16LJ39S71D16L	16	250	280	2000	3500	600	125.5
2.8APF19LJ39S71D16L	19	250	280	2000	3000	500	128.5
2.8APF22LJ39S71D16L	22	250	280	2000	3000	500	132.0
2.8APF25LJ39S71D16L	25	250	280	2000	3000	500	135.0
2.8APF28LJ39S71D16L	28	250	280	2000	3000	500	138.5
2.8APF30LJ39S71D16L	30	230	250	2000	3000	500	140.5
2.8APF32LJ39S71D16L	32	230	250	2000	3000	400	142.5
2.8APF36LJ39S71D16L	36	200	230	1500	2750	400	147.0
2.8APF40LJ39S71D16L	40	200	230	1500	2750	400	151.5
2.8APF43LJ39S71D16L	43	170	190	1500	2500	400	154.5
2.8APF45LJ39S71D16L	45	170	190	1500	2500	400	156.5

## Dimensions

### 2.8APF\*\*LJ39S71D16L

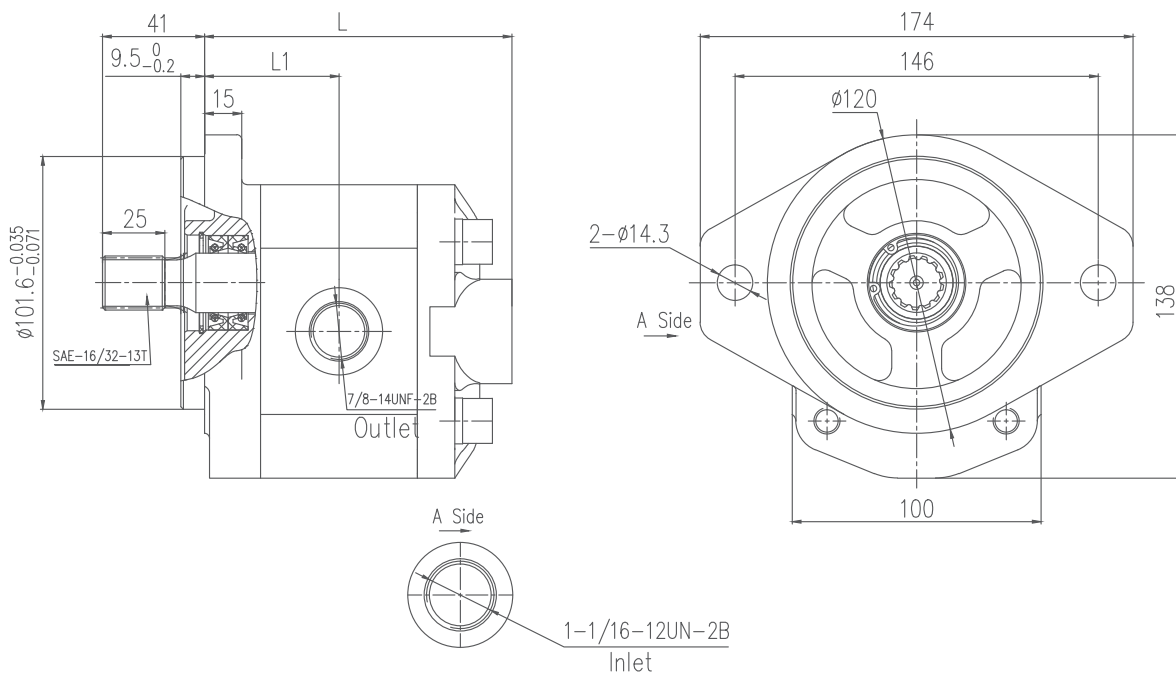



## 2.8XPF\*\*L\*\*S70D16



Model	Displacement (ml/r)	Pressure(bar)		Speed(r/min)			L1 (mm)	L (mm)	Inlet	Outlet
		Rated	Max.	Rated	Max.	Min.				
2.8XPF11L03S70D16	11	200	250	2000	3000	500	60.8	126.6	G1	G3/4
2.8XPF12L03S70D16	12	200	250	2000	3000	500	61.3	127.6		
2.8XPF15L03S70D16	15	200	250	2000	3000	500	62.8	130.5		
2.8XPF16L03S70D16	16	200	250	2000	3000	500	63.3	131.6		
2.8XPF19L03S70D16	19	200	250	2000	3000	500	64.8	134.6		
2.8XPF23L03S70D16	23	200	250	2000	3000	500	66.9	138.8		
2.8XPF25L03S70D16	25	200	250	2000	3000	500	67.9	140.8		
2.8XPF28L03S70D16	28	200	250	2000	3000	500	69.5	143.9		
2.8XPF34L03S70D16	34	200	250	2000	3000	500	72.6	150.1		
2.8XPF38L03S70D16	38	200	250	2000	3000	500	74.6	154.1		
2.8XPF40L03S70D16	40	200	250	2000	3000	500	75.6	156.1		

## Dimension

### 2.8XPF\*\*L03S70D16

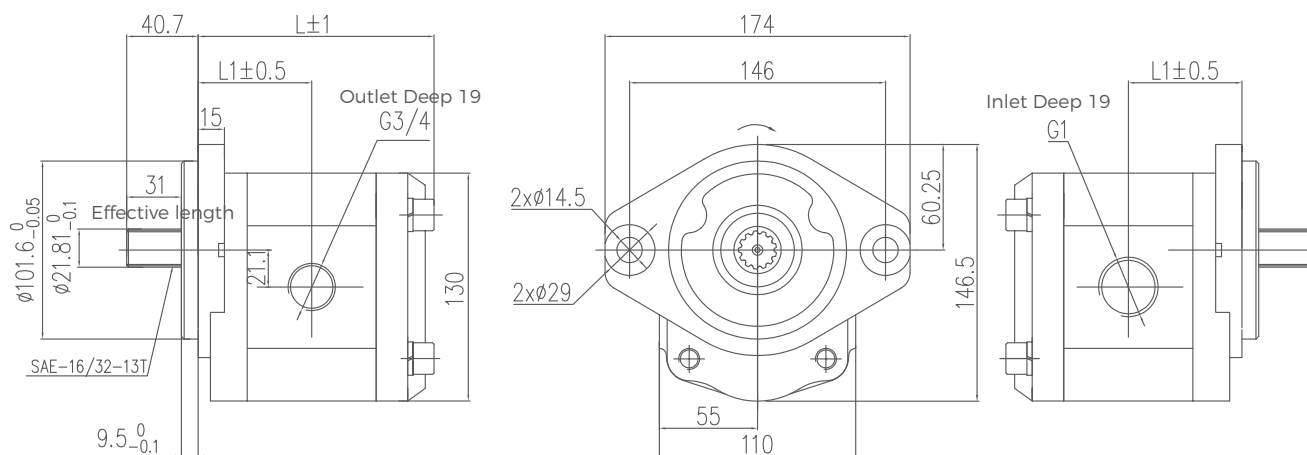













## Ordering Code

<b>3</b>	<b>A</b>	<b>P</b>	<b>F</b>	<b>60</b>	<b>L99</b>	<b>S71</b>	<b>D16</b>	<b>L-</b>	<b>SS</b>	<b>F-</b>	<b>O</b>	<b>-v</b>
a	b	c	d	e	f	g	h	i	j	k	i	m

- Ⓐ 3=Group 3
- Ⓑ Improved number  
A=Cast iron cover  
B=Special type
- Ⓒ P=Gear pump
- Ⓓ Pressure rate  
E=160bar  
F=200bar  
G=250bar
- Ⓔ Displacement(ml/r)  
22, 26, 34, 39, 43, 51, 60, 70, 78, 89
- Ⓕ L99=Line ports
- Ⓖ S71=Drive shaft
- Ⓗ D16=Front cover
- Ⓘ Rotation  
R=CW  
L=CCW  
B=Bi-directional

- Ⓙ Ports combination  
SS=Side inlet and side outlet  
SB=Side inlet and back outlet  
BS=Back inlet and side outlet  
BB=Back inlet and back outlet
- Ⓚ Seal  
F=FKM seal  
Omit=NBR seal
- Ⓛ Outboard bearing  
O=Outboard bearing  
Omit=Without outboard bearing
- Ⓜ Option  
V=Relief valve  
D=Check valve

Ⓕ Line ports Inlet/Outlet			Ⓖ Drive shaft			Ⓗ Front cover		
L69	G3/4 G3/4		T11	Tapered key shaft 1:8		S14	4-hole mounting 98.5 x128mm	
L03	G1 G3/4		S71	Splined shaft 13 teeth 21.81mm		D16	2-hole mounting Ø146mm	
L11	G1-1/4 G1					D12	2-hole mounting Ø146mm	
L99	G1-1/4 G1-1/4							
LJ42	1-5/16-12UN-2B 1-1/16-12UN-2B							
LJ53	1-5/8-12UN-2B 1-5/16-12UN-2B							
F10	Ø56, M10, Ø27 Ø56, M10, Ø19							

**3APF\*\*F\*\*T11S14\***

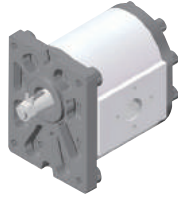

Model	Displacement (ml/r)	Pressure(bar)		Speed(r/min)			L (mm)	L1 (mm)	ØD1	Ød1	T1	ØD2	Ød2	T2
		Rated	Peak	Rated	Max.	Min.								
3APF22F10T11S14	22	200	250	2000	3000	400	128.5	65.5	56	27	M10	56	19	M10
3APF26F10T11S14	26	200	250	2000	3000	400	131.5	67.0						
3APF34F10T11S14	34	200	250	2000	3000	400	137.0	69.8						
3APF39F10T11S14	39	200	250	2000	3000	400	141.0	71.8						
3APF43F09T11S14	43	200	250	2000	2800	400	143.5	73.0	51	27	M10	51	27	M10
3APF51F11T11S14	51	200	250	2000	2400	400	149.5	76.0	56	27		56	27	
3APF60F12T11S14	60	180	230	1500	2800	400	156.0	79.3	62	33		51	27	
3APF70F12T11S14	70	180	200	1500	2500	400	163.0	82.8						
3APF78F12T11S14	78	160	200	1500	2300	400	169.2	85.2						
3APF89F12T11S14	89	140	180	1500	2000	400	174.2	88.2						

**Dimensions**

**3APF\*\*F\*\*T11S14\***

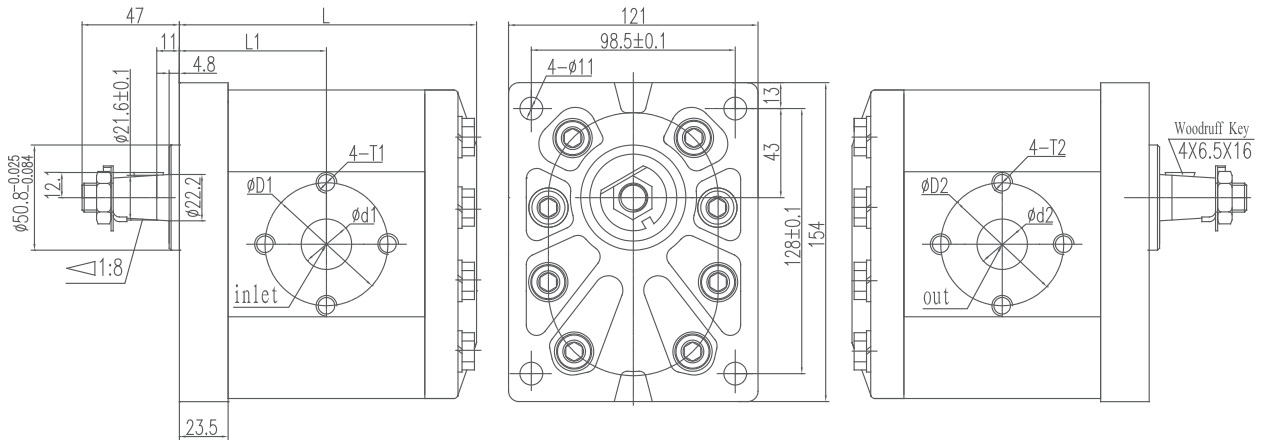

**3APF\*\*F12T47S18L**

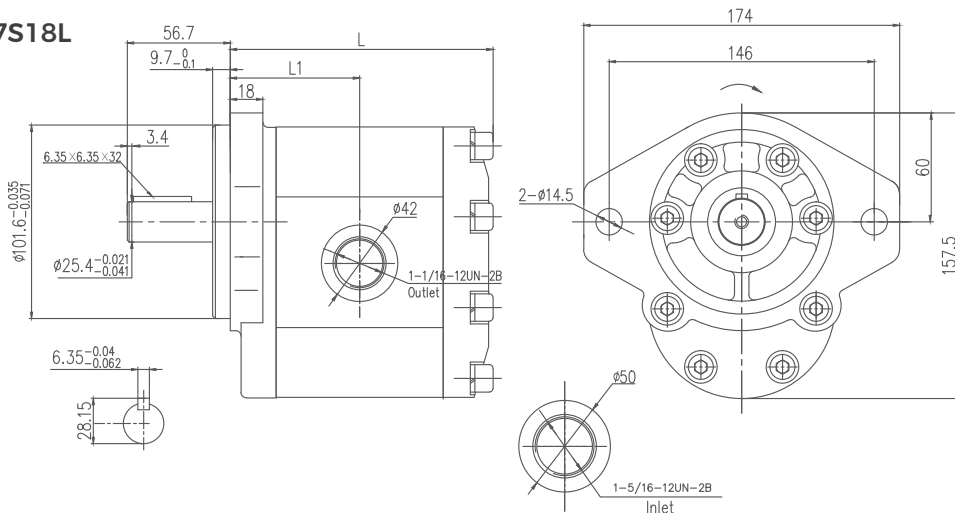

**3APF\*\*F32S70D12\***



Model	Displacement (ml/r)	Pressure(bar)		Speed(r/min)			L (mm)	L1 (mm)	L2 (mm)	B2 (mm)	D1 (mm)	T1 (mm)	L3 (mm)	B3 (mm)	D2 (mm)	T2 (mm)
		Rated	Peak	Rated	Max.	Min.										
3APF22F32S70D12	22	200	250	2000	3000	400	130.3	65.3	52.4	26.2	27	3/8 16- UNC -2B	26.2	47.6	19	3/8  16- UNC -2B
3APF26F32S70D12	26	200	250	2000	3000	400	133.3	66.8								
3APF34F32S70D12	34	200	250	2000	3000	400	138.8	69.6								
3APF39F32S70D12	39	200	250	2000	3000	400	142.8	71.6								
3APF43F32S70D12	43	200	250	2000	2800	400	145.3	72.8								
3APF51F32S70D12	51	200	250	2000	2400	400	151.3	75.8								
3APF60F36S70D12	60	180	230	1500	2800	400	157.8	79.1	58.7	28.4	33	7/16 14- UNC -2B	26.2	52.4	27	
3APF70F36S70D12	70	180	200	1500	2500	400	164.8	82.5								
3APF78F36S70D12	78	160	200	1500	2300	400	171.0	85.0								
3APF89F36S70D12	89	140	180	1500	2000	400	176.0	88.0								

**Dimensions**

**3APF\*\*F\*\*S70D12\***

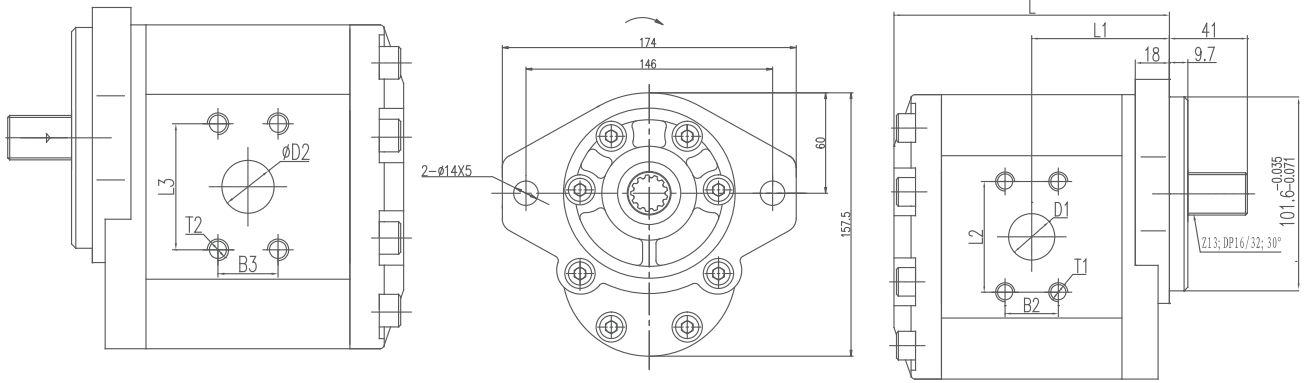

**3APF\*\*F52S81D12L**

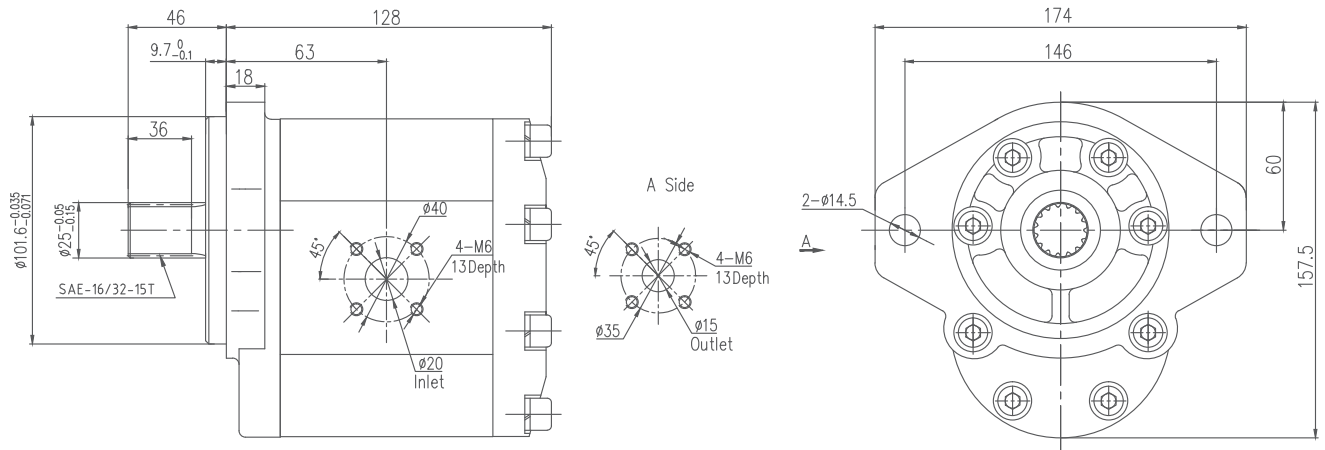

**3APF\*\*F\*\*F12D12\***

Model	Displacement (ml/r)	Pressure(bar)		Speed(r/min)			L (mm)	L1 (mm)	L2 (mm)	B2 (mm)	ØD1 (mm)	T1 (mm)	L3 (mm)	B3 (mm)	ØD2 (mm)	T2 (mm)
		Rated	Peak	Rated	Max.	Min.										
3APF22F32F12D12*	22	200	250	2000	3000	400	130.3	65.3								
3APF26F32F12D12*	26	200	250	2000	3000	400	133.3	66.8				3/8				
3APF34F32F12D12*	34	200	250	2000	3000	400	138.8	69.6	52.4	26.2	27	16UNC	26.2	47.6	19	3/8
3APF39F32F12D12*	39	200	250	2000	3000	400	142.8	71.6								
3APF43F32F12D12*	43	200	250	2000	2800	400	145.3	72.8				-2B				16UNC
3APF51F32F12D12*	51	200	250	2000	2800	400	151.3	75.8								
3APF60F36F12D12*	60	180	230	1500	2800	400	157.8	79.1				7/16				-2B
3APF70F36F12D12*	70	180	200	1500	2500	400	164.8	82.5	58.7	28.4	33	14UNC	26.2	52.4	27	-2B
3APF78F36F12D12*	78	160	200	1500	2300	400	171.0	85.0								
3APF89F36F12D12*	89	140	180	1500	2000	400	176.0	88.0								

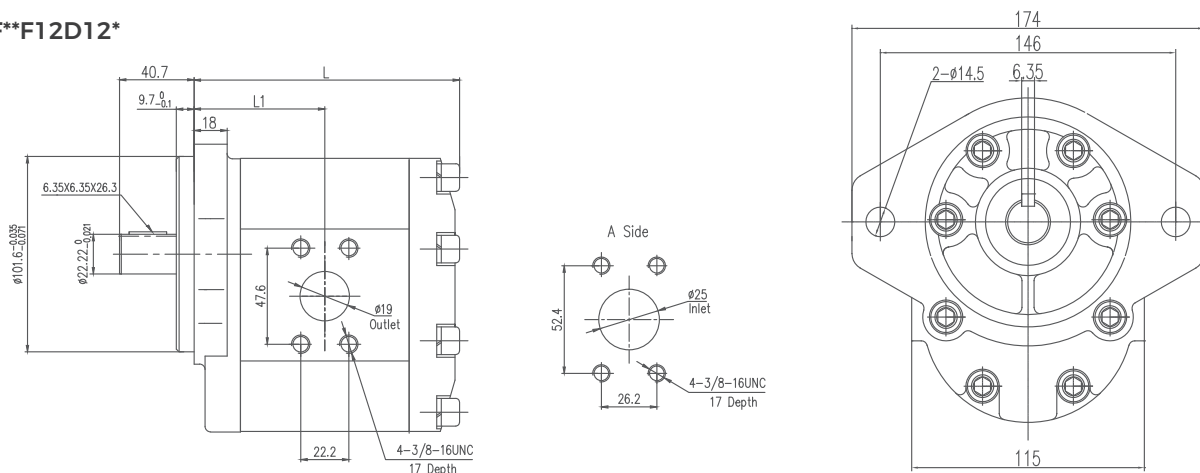
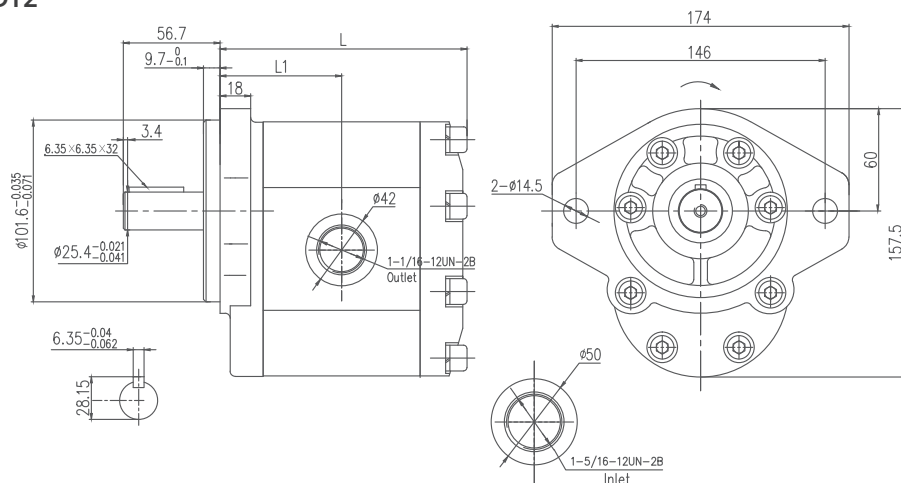
**Dimensions****3APF\*\*F\*\*F12D12\*****3APFLJ42F100D12**

**3BPF\*\*LJ\*\*S70SP10\***



Model	Displacement (ml/r)	Pressure(bar)		Speed(r/min)			L (mm)	L1 (mm)	T1 (mm)	T2 (mm)
		Rated	Peak	Rated	Max.	Min.				
3BPF22LJ53S70SP10*	22	200	250	2000	3000	400	111.6	85.6	1-5/8-12UNC-2B	1-5/16-12UNC-2B
3BPF26LJ53S70SP10*	26	200	250	2000	3000	400	114.5	88.5		
3BPF34LJ53S70SP10*	34	200	250	2000	3000	400	120.2	94.2		
3BPF39LJ53S70SP10*	39	200	250	2000	3000	400	123.8	97.8		
3BPF43LJ53S70SP10*	43	200	250	2000	2800	400	126.5	100.5		
3BPF50LJ53S70SP10*	50	200	250	2000	2400	400	131.5	105.5		
3BPF60LJ53S70SP10*	60	180	230	1500	2400	400	138.5	112.5		
3BPF63LJ53S70SP10*	63	180	200	1500	2100	400	140.8	114.8		

**Dimensions**

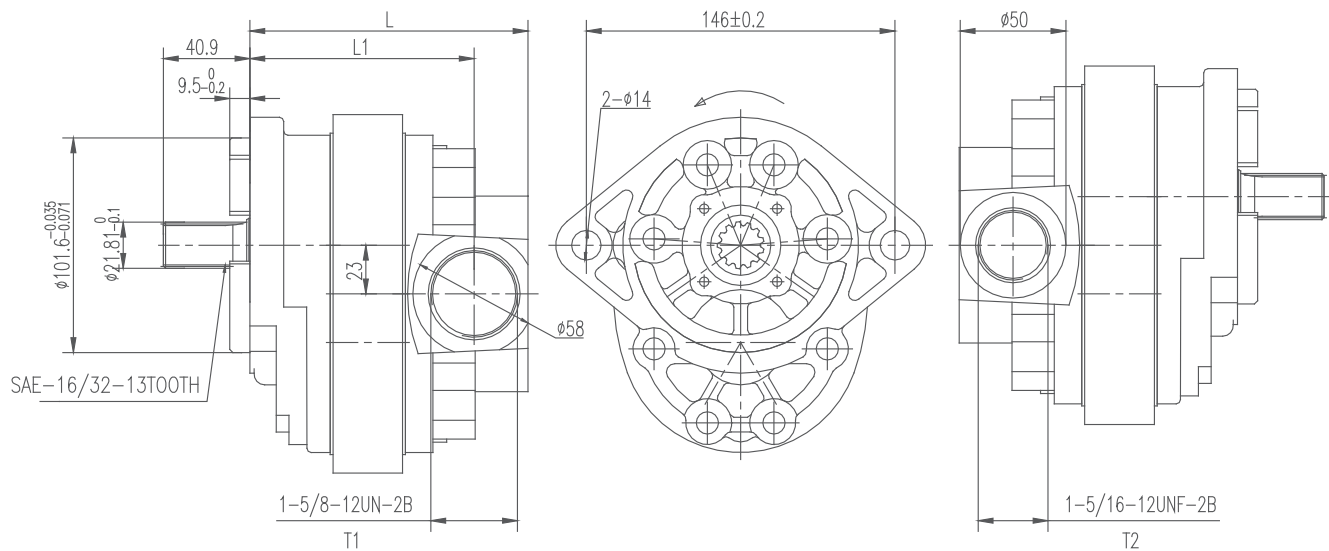

**Ordering Code**

3	B	P	F	**	LJ53	S70SP10	/L
Group 3	Structure improve number	Gear pump	F:16 ~ 25 Mpa	Displacement 22, 26, 34, 39, 43, 50, 60, 63 ml/r	Inlet/outlet combination	Shaft and flange combination	Rotation L= left omit = right

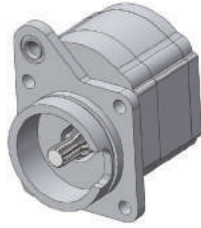
**OM08GR08K04S90SP21**

Model	Displacement (ml/r)	Pressure(bar)		Speed(r/min)		
		Rated	Peak	Rated.	Max.	Min.
OM08GR08K04S90SP21	48	100	140	1500	2500	500

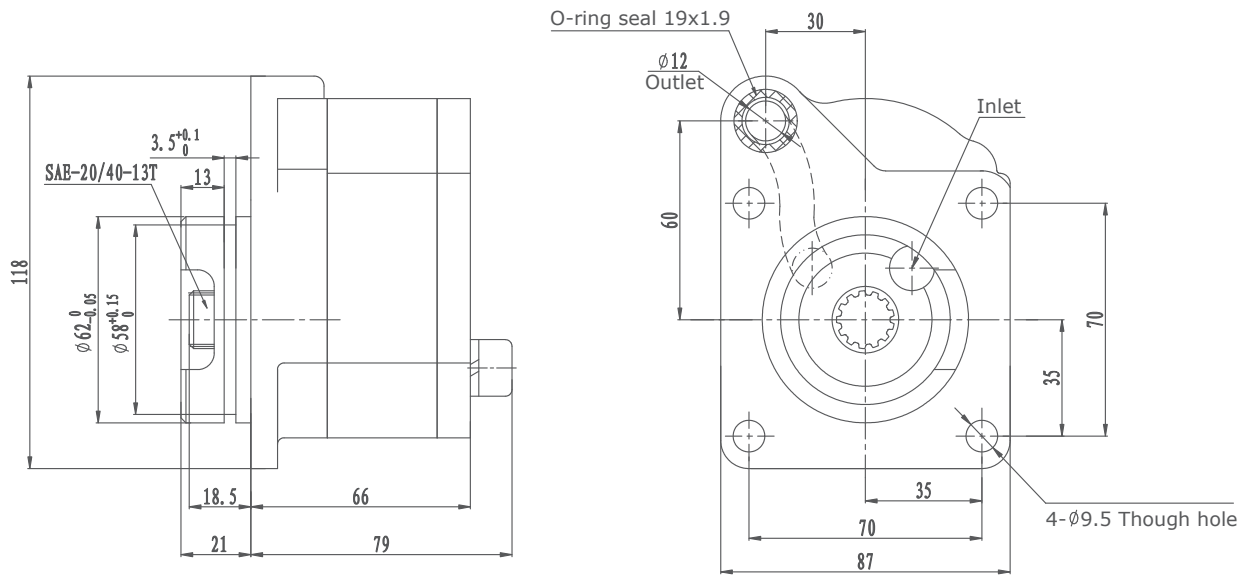
**OM08-3GR\*\*K03S91SP22**

Model	Displacement (ml/r)	Pressure(bar)		Speed(r/min)		
		Rated	Peak	Rated	Max.	Min.
OM08-3GR12K03S91SP22	12	100	140	1500	2500	500

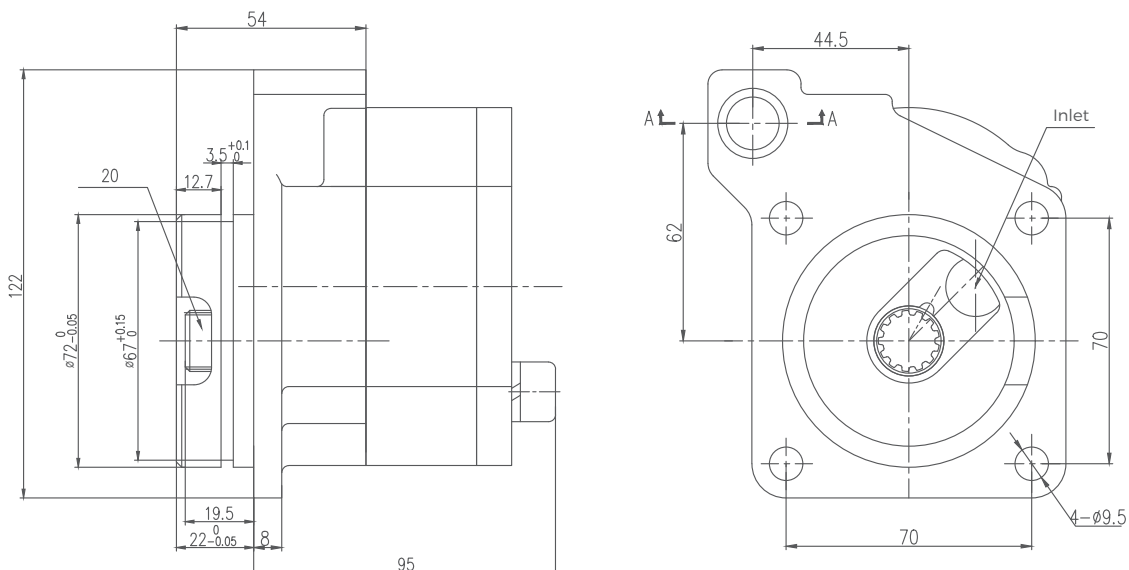



**OM401GR18K05S87SP18-X**

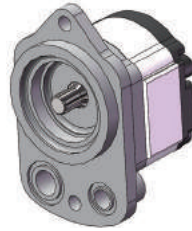

Model	Displacement (ml/r)	Pressure(bar)		Speed(r/min)			Inlet	Outlet
		Rated	Peak	Rated	Max.	Min.		
OM401GR18K05S87SP18-X	18	140	160	1500	2500	600	Φ18	Φ14

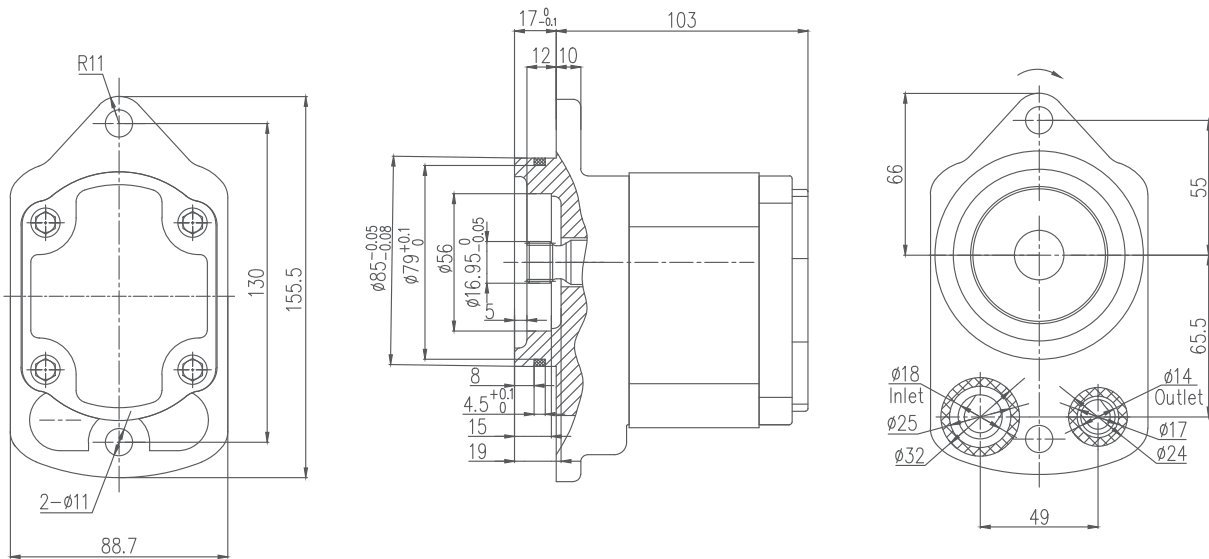

**OM601GR18K05S89SP20-X/S88SP19-X**

Model	Displacement (ml/r)	Pressure(bar)		Speed(r/min)			Inlet	Outlet
		Rated	Peak	Rated	Max.	Min.		
OM601GR18K05S89SP20-X	18	140	160	1500	2500	600	Φ18	Φ14
OM601GR18K05S88SP19-X	18	140	160	1500	2500	600	Φ18	Φ14

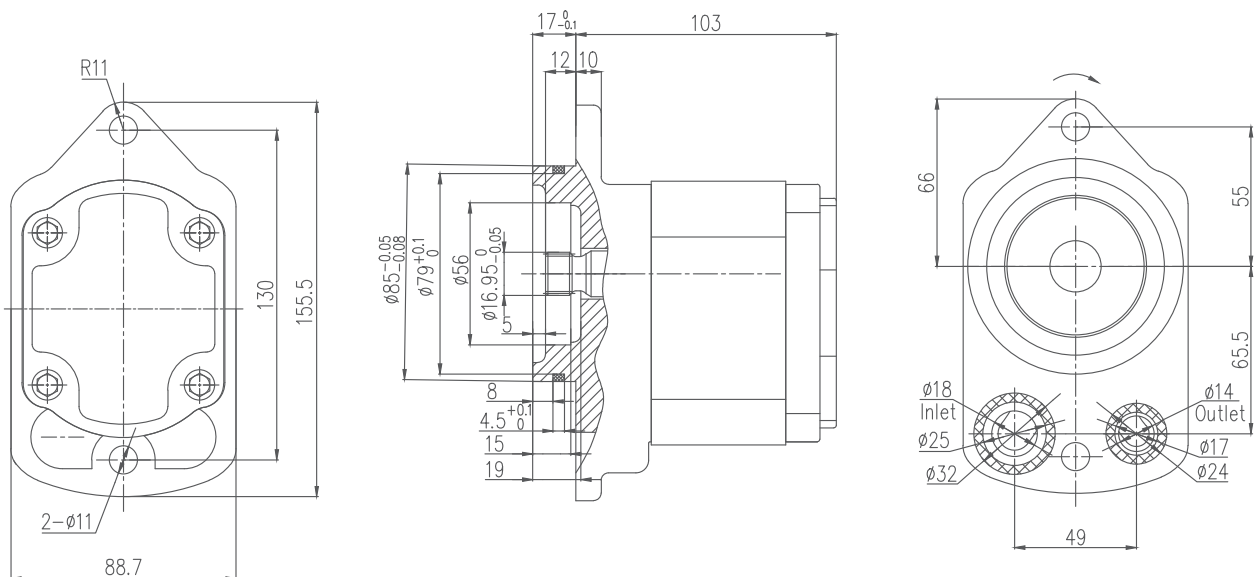

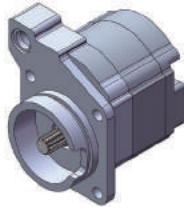
**OM701GR17K03S86SP17-X**

Model	Displacement (ml/r)	Pressure(bar)		Speed(r/min)		
		Rated	Peak	Rated	Max.	Min.
OM701GR17K03S86SP17-X	17	140	160	1500	2500	600

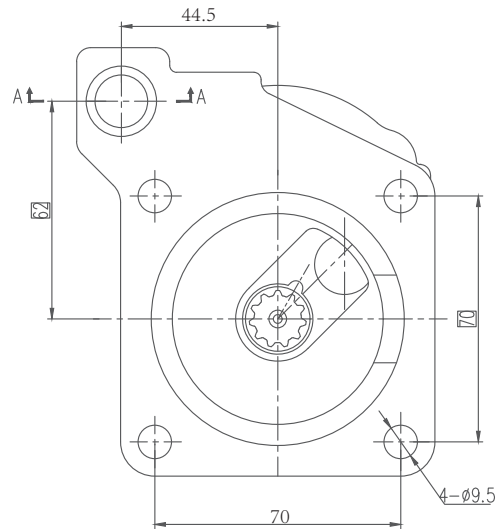
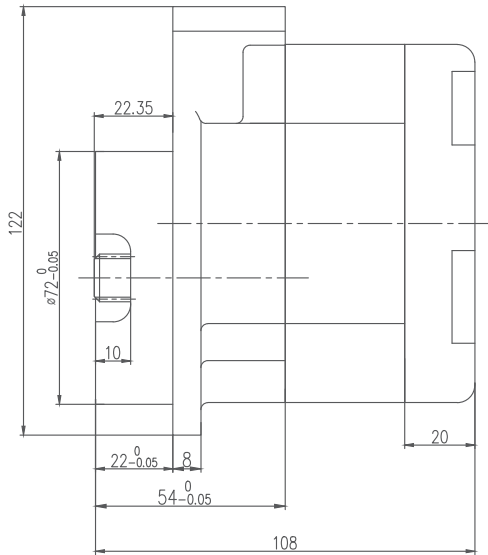
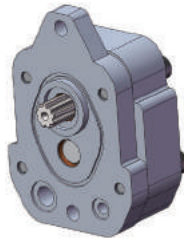
**OM702GR10K04S84D14**

Model	Displacement (ml/r)	Pressure(bar)		Speed(r/min)			Inlet	Outlet
		Rated	Peak	Rated	Max.	Min.		
OM702GR10K04S84D14	10	100	160	1500	2500	600	$\phi 14$	$\phi 8$

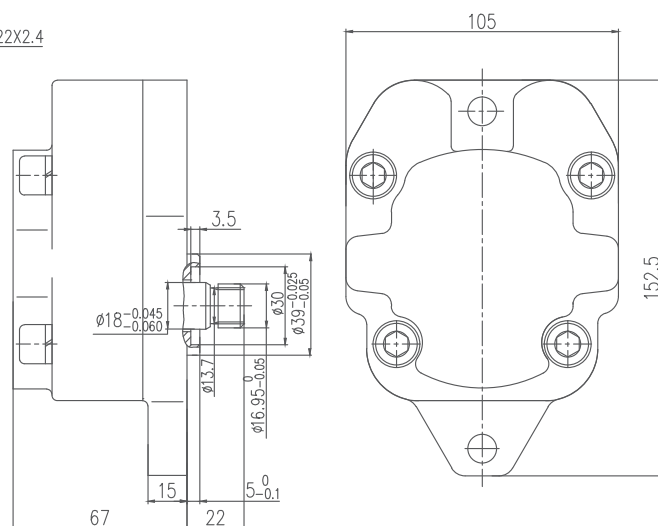
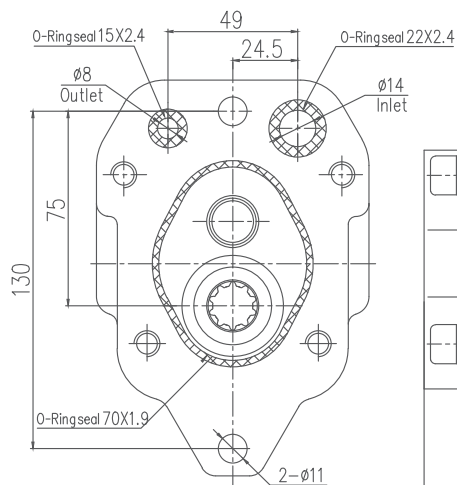

**OM14GR\*\*LJ41F107SP16**

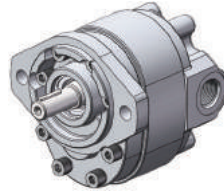

Model	Displacement (ml/r)	Pressure(bar)		Speed(r/min)			L (mm)	L1 (mm)	Inlet	Outlet
		Rated	Peak	Rated	Max.	Min.				
OM14GR17LJ41F107SP16	17	160	180	1500	2500	500	104.5	84.0	1-5/16-12UN-2B	7/8-14UNF-2B
OM14GR20LJ41F107SP16	20	160	180	1500	2500	500	108.0	87.5		
OM14GR23LJ41F107SP16	23	160	180	1500	2500	500	112.0	91.5		
OM14GR24LJ41F107SP16	24	160	180	1500	2500	500	113.0	92.5		
OM14GR25LJ41F107SP16	25	160	180	1500	2500	500	114.0	93.5		
OM14GR28LJ41F107SP16	28	160	180	1500	2500	500	117.5	97.0		
OM14GR29LJ41F107SP16	29	160	180	1500	2500	500	119.0	98.5		
OM14GR30LJ41F107SP16	30	160	180	1500	2500	500	120.0	99.5		

**Dimensions**

**OM14GR\*\*LJ41F107SP16**

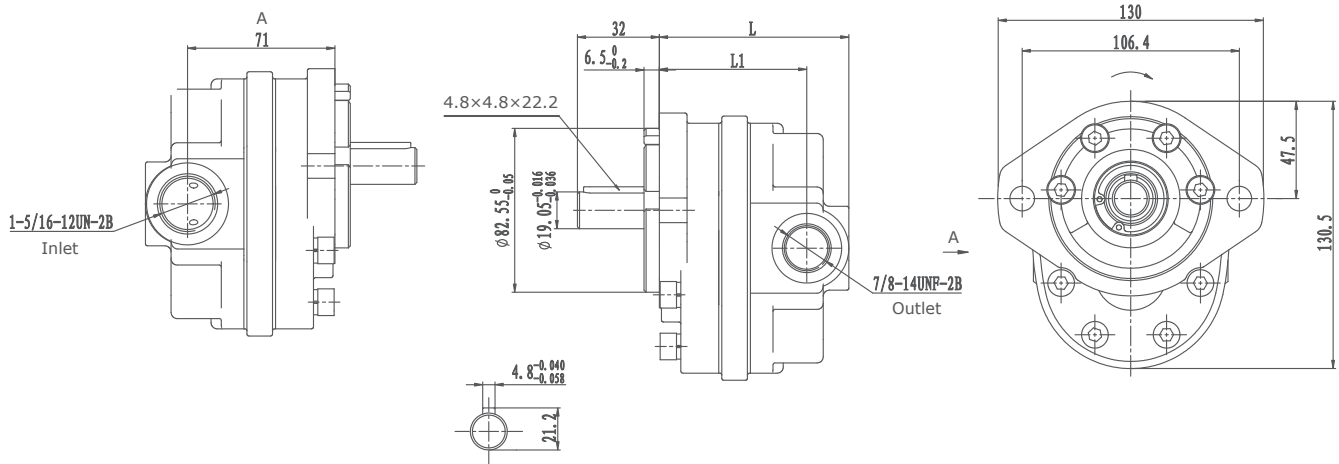

## 2CP 18 Constant Flow Gear Pumps



Model	Displacement(ml/r)	Constant flow(L/min)	Max Pressure(bar)	Speed(r/min)
2[C]P18 16/14L17F106D18SS	18	16	10	500-3200

### Involute Spline Parameter

m	Z	Pressure angle	Precision
1	16	300	5h

### Dimensions

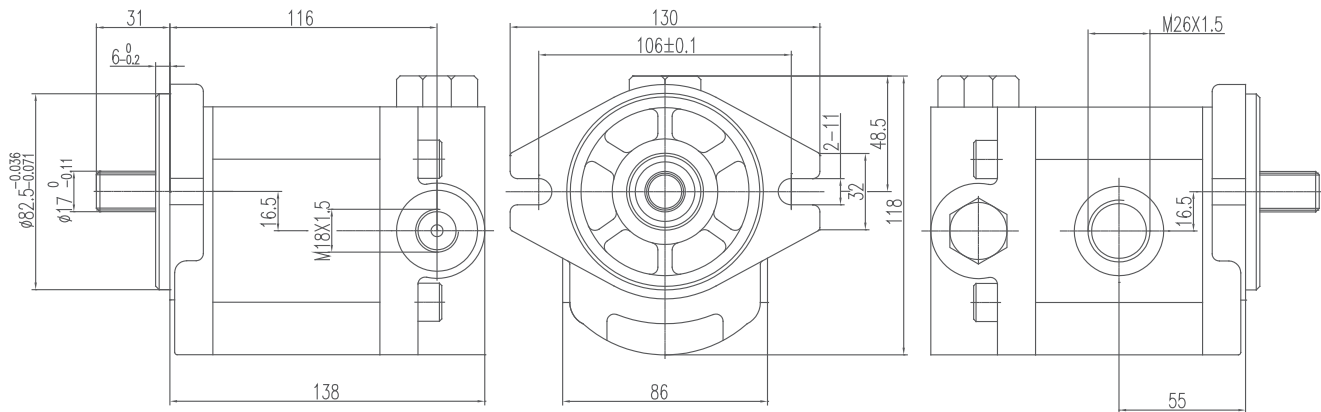

### Ordering Code

2	[C]P	**	16/14	L17	F106D18	/L	SS
Group 2	Constant flow Gear pump	Displacement 18 ml/r	Control flow: 16L/min safety valve pressure: 14MPa	Inlet/outlet combination	Shaft and flange combination	Rotation L= left omit = right	inlet/out position combination BB, BS, SB, SS

## 2CP 18 Constant Flow Gear Pumps

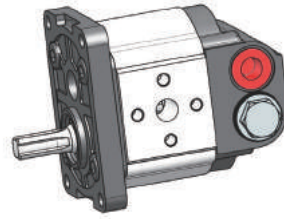

Model	Displacement (ml/r)	Constant flow (L/min)	Max. Pressure (bar)	Speed (r/min)	L	L1	L2
2[C]P6 6/12.5LF01R17S7LSS	6	6	125	500-3200	47.0	98.0	120.0
2[C]P10 6/12.5LF01R17S7LSS	10	6	125	500-3200	49.75	103.5	125.5
2[C]P14 10/12.5LF01R17S7LSS	14	10	125	500-3200	52.85	109.5	131.7

## Dimensions

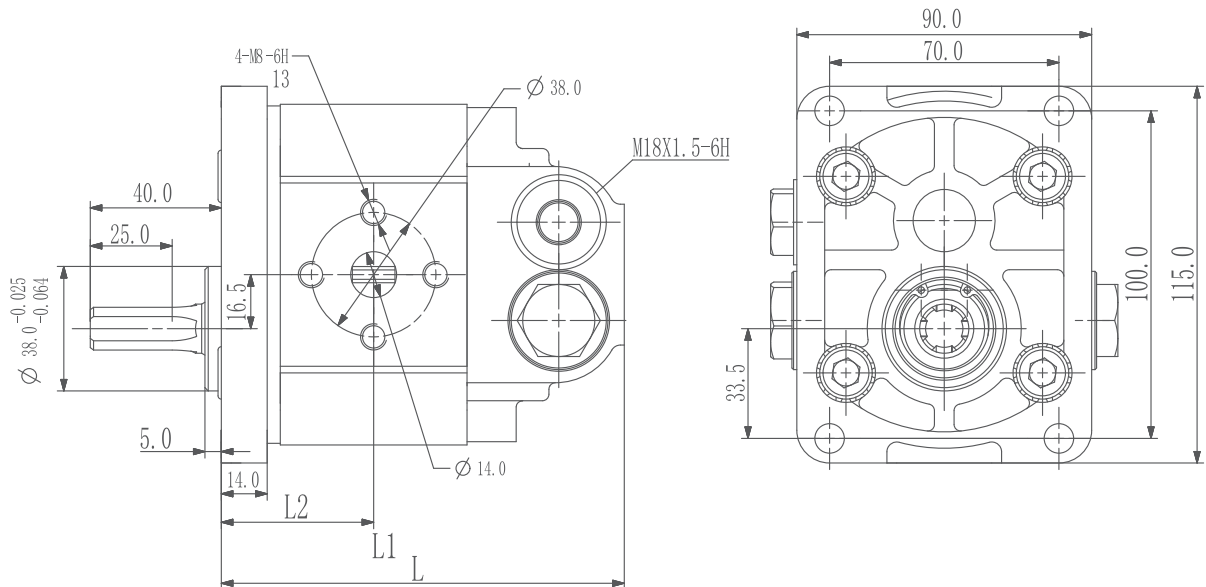

## Ordering Code

2	[C]P	**	*/12.5	LF01	R17S7	/L	SS
Group 2	Constant flow	Displacement 6, 10, 14 ml/r	Control flow: 6, 10L/min safety valve pressure: 12.5 MPa	Inlet/outlet combination	Shaft and flange combination	Rotation L= left omit = right	inlet/out position combination BB, BS, SB, SS

## 2CB-E\*\*/\*\* HI/LO Gear Pumps



Model	Flow (gpm)	Pressure(PSI)		Displacement (Cu.in/r)		Speed (rpm)	D	
		LO	HI	LO	HI		Inlet	Outlet
2CB-E6.3/2.1	8.0	400/900	3000	0.385	0.130	3600	1 IN PIPE	1/2 NPT
2CB-E6.3/3.0	8.5	400/900	3000	0.385	0.183			
2CB-E6.3/3.6	9.0	400/900	3000	0.385	0.220			
2CB-E8.8/2.1	10.0	400/900	3000	0.537	0.130			
2CB-E8.8/3.0	10.5	400/900	3000	0.537	0.183			
2CB-E8.8/3.6	11.0	400/900	3000	0.537	0.220			
2CB-E8.8/4.2	11.5	400/900	3000	0.537	0.256			
2CB-E10.9/2.1	12.0	400/900	3000	0.665	0.130			
2CB-E10.9/3.0	12.5	400/900	3000	0.665	0.183			
2CB-E10.9/3.6	13.0	400/900	3000	0.665	0.220			
2CB-E10.9/4.2	13.5	400/900	3000	0.665	0.256			
2CB-E13.0/4.2	16.0	400/900	3000	0.793	0.265			

## Dimensions

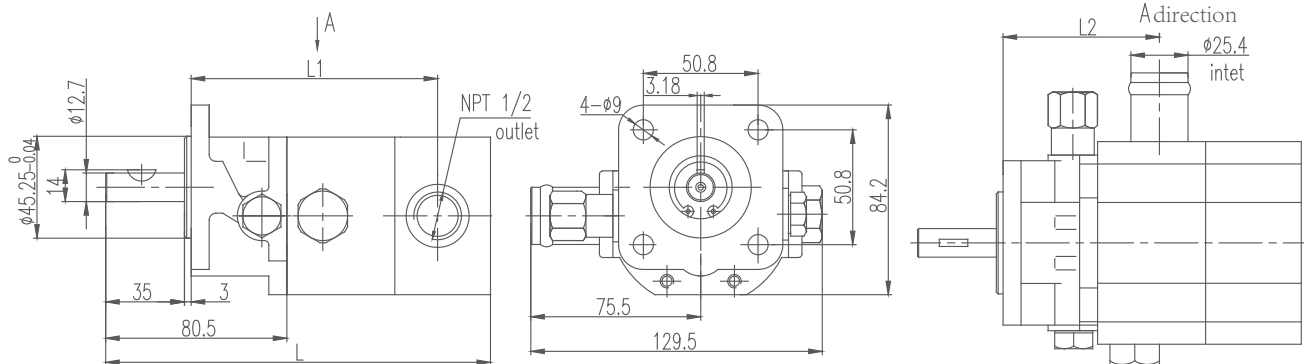

Model	Dimension/In			Model	Dimension/In			Model	Dimension/In		
	L	L1	L2		L	L1	L2		L	L1	L2
2CB-E6.3/2.1	6.07	3.74	2.41	2CB-E8.8/3.0	6.54	4.08	2.74	2CB-E10.9/3.0	6.90	4.53	3.04
2CB-E6.3/3.0	6.21	3.90	2.41	2CB-E8.8/3.6	6.61	4.24	2.74	2CB-E10.9/3.6	7.00	4.53	3.04
2CB-E6.3/3.6	6.28	3.90	2.74	2CB-E8.8/4.2	6.70	4.24	2.74	2CB-E10.9/4.2	7.09	4.53	3.04
2CB-E8.8/2.1	6.41	4.08	2.74	2CB-E10.9/2.1	6.70	4.37	3.04	2CB-E13.0/4.2	6.70	4.37	3.04

## 2CB-P\*\*/\*\* HI/LO Gear Pumps

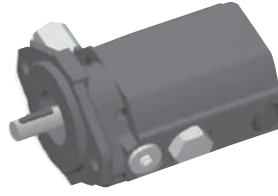

Model	Flow (gpm)	Pressure (PSI)		Displacement (Cu.in/r)		Speed (rpm)	D	
		LO	HI	LO	HI		Inlet	Outlet
2CB-P15.2/7.6	22	400/900	3000	0.930	0.465	3600	NPTF 1 G1	NPTF3/4 G3/4
2CB-P22.9/7.6	28	400/900	3000	1.395	0.465			

## Dimensions

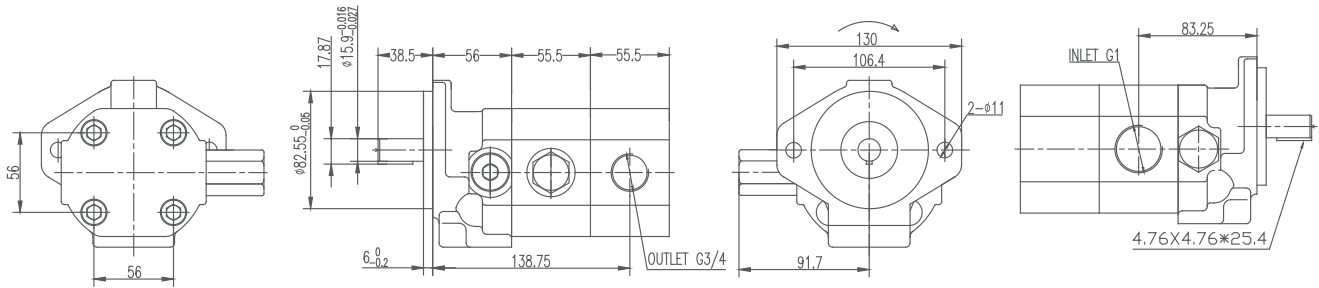

## Performance curves

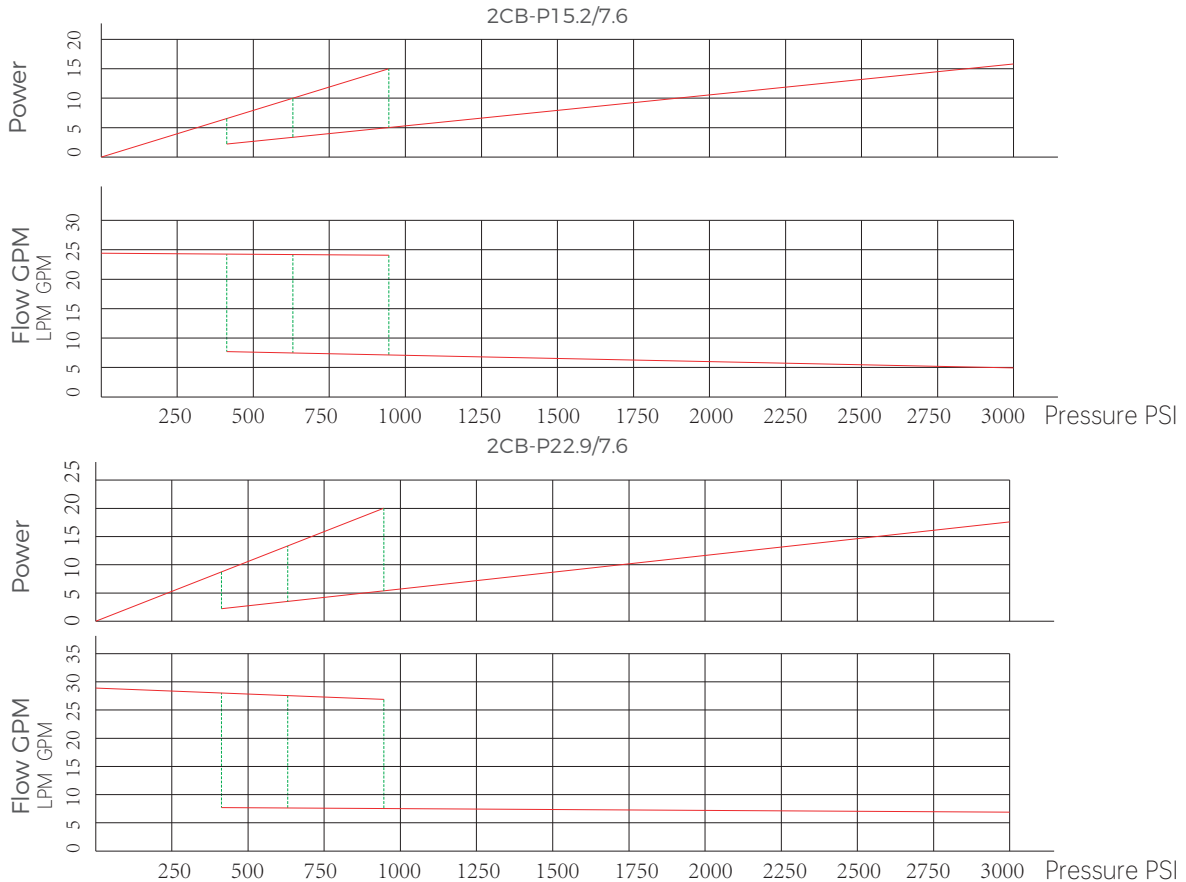



## PTO Gear Pumps



PTO pump can be used in the hydraulic systems of agricultural tractors

Model	Displacement (cc/r)	Pressure	Speed	L1 (mm)	L2 (mm)	L3 (mm)	L4 (mm)	L5 (mm)
		Max.	Rated					
CB-P160LJ53S33BB	160	160 bar (2250 psi)	1000RPM	60.2	53.0	86	161	61.0
CB-P125LJ53S33BB	125			50.8	50.8	81	151	52.0
CB-P90LJ53S33BB	90			41.5	44.0	76	142	47.5
CB-P56LJ53S33BB	56			32.0	39.0	71	133	42.5
CB-P160LJ42H21SS	160		540RPM	60.2	53.0	86	161	61.0
CB-P125LJ42H21SS	125			50.8	48.0	81	151	52.0
CB-P90LJ42H21SS	90			41.5	44.0	76	142	47.5
CB-P56LJ42H21SS	56			32.0	39.0	71	133	42.5

## Dimensions

### CB-P\*\*\*LJ53S33BB

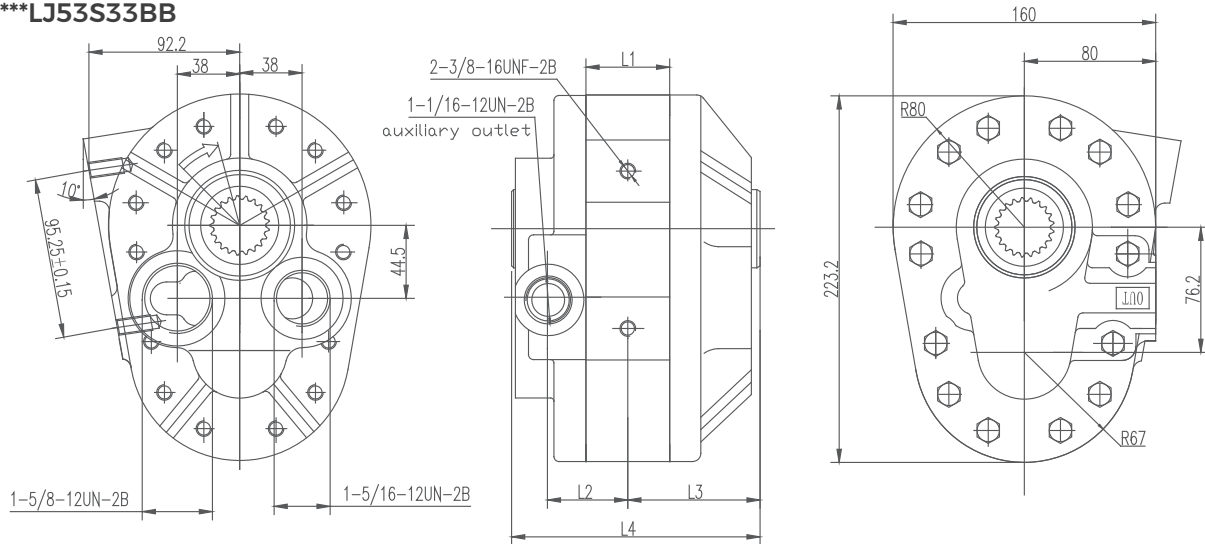

### CB-P\*\*\*LJ42H21SS

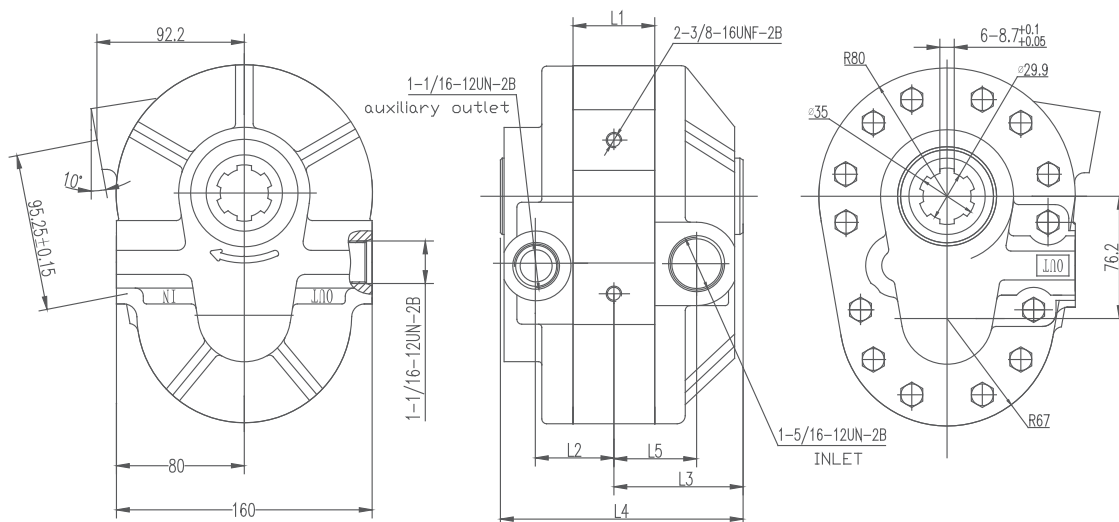

## Ordering Code

<b>1</b>	<b>D</b>	<b>P</b>	<b>F</b>	<b>**/**</b>	<b>DL01</b>	<b>T24</b>	<b>S7</b>	<b>L-</b>	<b>SS</b>	<b>F-</b>	<b>O</b>	<b>-V</b>
a	b	c	d	e	f	g	h	i	j	k	l	m

Ⓐ 1=Group 1

1, 1.5, 2, 3 Group

Ⓑ Function

D=Double pump

T=Triple pump

F=Four stage pump

Ⓒ P=Gear pump

Ⓓ Pressure rate

E=160bar

F=200bar

G=250bar

Ⓔ Displacement(ml/r)

first stage/second stage/third stage/forth stage

Ⓕ DL01=Line ports

Ⓖ T24=Drive shaft

Ⓗ S7=Front cover

Ⓘ Rotation

R=CW

L=CCW

B=Bi-directional

Ⓚ Ports combination

SS=Side inlet and side outlet

SB=Side inlet and back outlet

BS=Back inlet and side outlet

BB=Back inlet and back outlet

Ⓛ Seal

F=FKM seal

Omit=NBR seal















Ⓛ Outboard bearing

O=Outboard bearing

Omit=Without outboard bearing

Ⓜ Options

V(Relief valve)/D(Check valve)

Ⓕ Line ports Front Pump Inlet/Outlet Back Pump Inlet/Outlet			Ⓖ Drive shaft			Ⓗ Front cover		
DF02	Ø40,4-M8, Ø20 Ø30,4-M6, Ø13		T10	Tapered key shaft 1:5		S7	4-hole mounting 71.5 x 96.2mm	
	Ø40,4-M8, Ø20 Ø30,4-M6, Ø13		T24	Tapered key shaft 1:8		D9	2-groove mounting Ø106mm	
DF05	Ø40,4-M6, Ø20 Ø35,4-M6, Ø15		F32	Straight keyed shaft SAE A Ø15.88mm		S14	4-hole mounting 98.5 x 128mm	
	Ø40,4-M6, Ø20 Ø35,4-M6, Ø15		S13	Splined shaft 9teeth 15.45mm		D12	2-hole mounting Ø146mm	
DF08	Ø56,4-M10, Ø27 Ø56,4-M10, Ø27							
	Ø38,4-M8, Ø18 Ø38,4-M8, Ø15							

**1DPF\*\*/\*\*DL\*\*F16D2\***

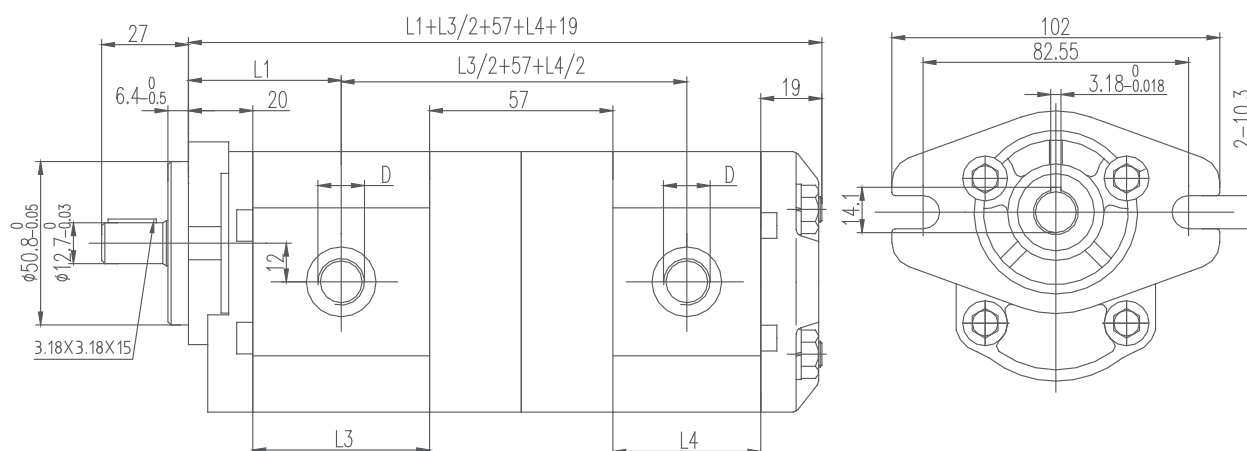

Displacement(ml/r)	1.3	2.0	2.7	3.4	4.1	5.1	6.1
L3/L4	44	46	48	50	52	55	58
L	82	84	86	88	90	93	96
L1	42.0	43.0	44.0	45.0	46.0	47.5	49.0

**Dimensions**

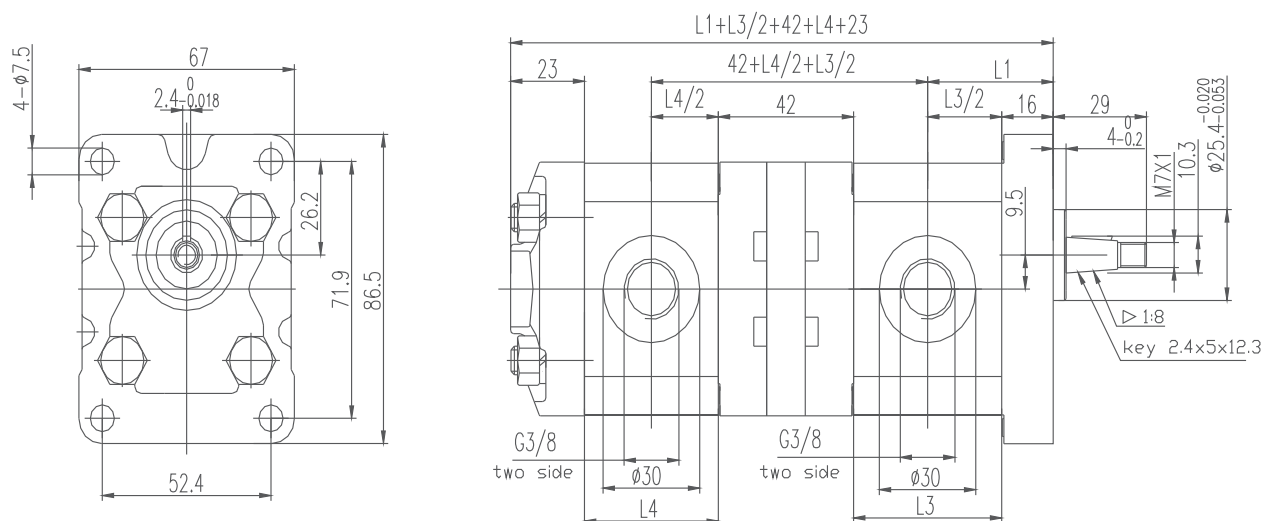
**1DPF\*\*/\*\*DL\*\*T3S5\***

Displacement(ml/r)	1.1	1.3	1.6	2.1	3.2	3.7	4.2	4.8	5.8	8.0
L3/L4	36	37	38	40	44	46	48	50	54	62
L	75	76	78	79	83	85	87	89	93	101
L1	33	34	35	36	38	39	40	41	43	47

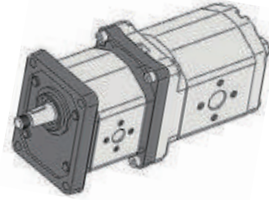

**1DPF\*\*/\*\*DF\*\*T52S23\***



Displacement(ml/r)	1.4	2.1	2.8	3.5	4.1	5.2	5.2	6.2	7.6	9.3	9.6	11.0	13.8
L1	44.1	46.1	48.1	50.1	52.1	55.1	55.1	58.1	63.1	67.1	69.1	73.1	81.6
L2	44.1	46.1	48.1	50.1	52.1	55.1	55.1	58.1	63.1	67.1	69.1	73.1	81.6

**Dimensions**

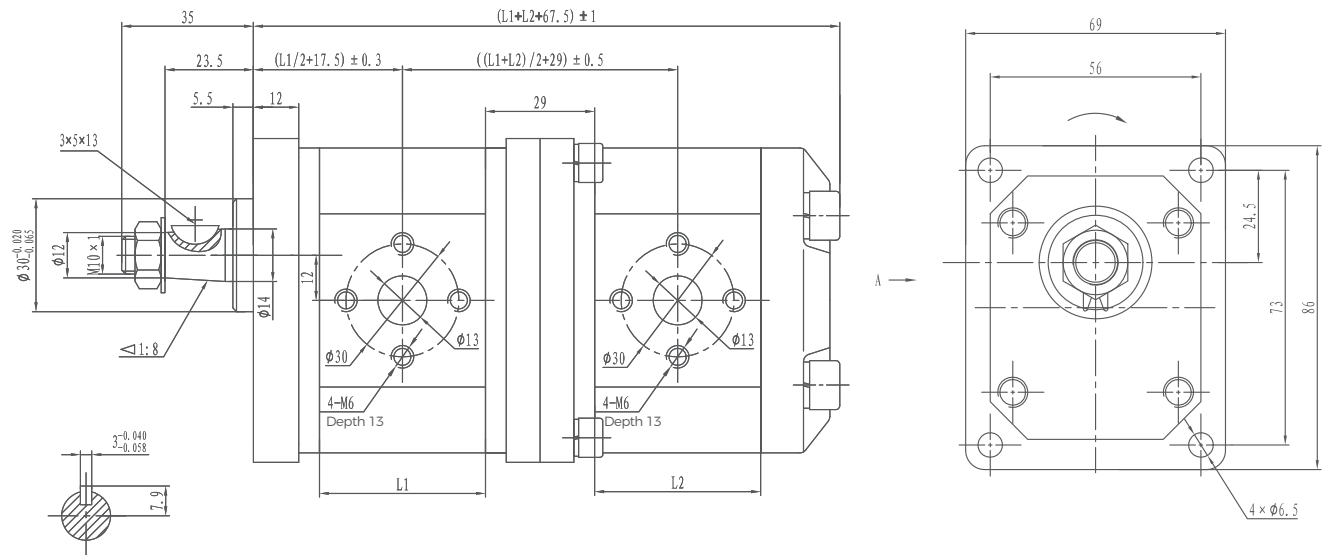

**1.5DPF\*\*/\*\*DF50F13S3\***

Displacement(ml/r)	2	3	4	5	6	7	8	9	10	11	12
L1	42	44	46	48	50	52	54	56	58	60	62

**Dimensions**

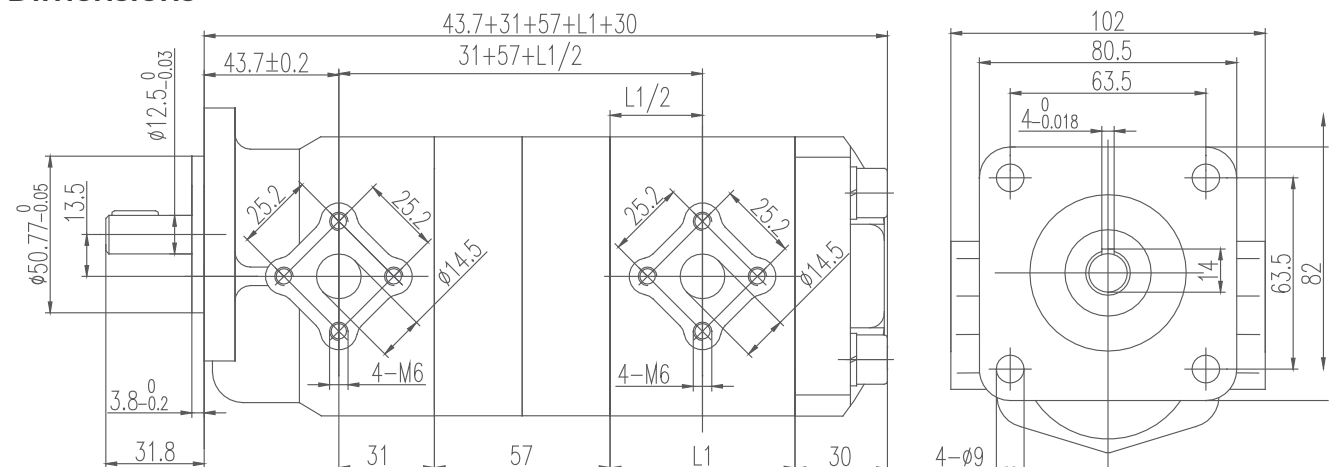



## 1/2DPF3.5/9.6DF161T52S23

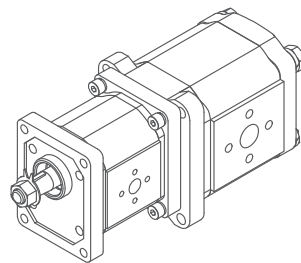

Model	Displacement(ml/r)	Pressure(bar)		Speed(r/min)		
		Rated	Peak	Rated	Max.	Min.
2DPF3.5/9.6DF161T52S23	3.5/9.6	280	310	2000	5000	500

## Dimensions

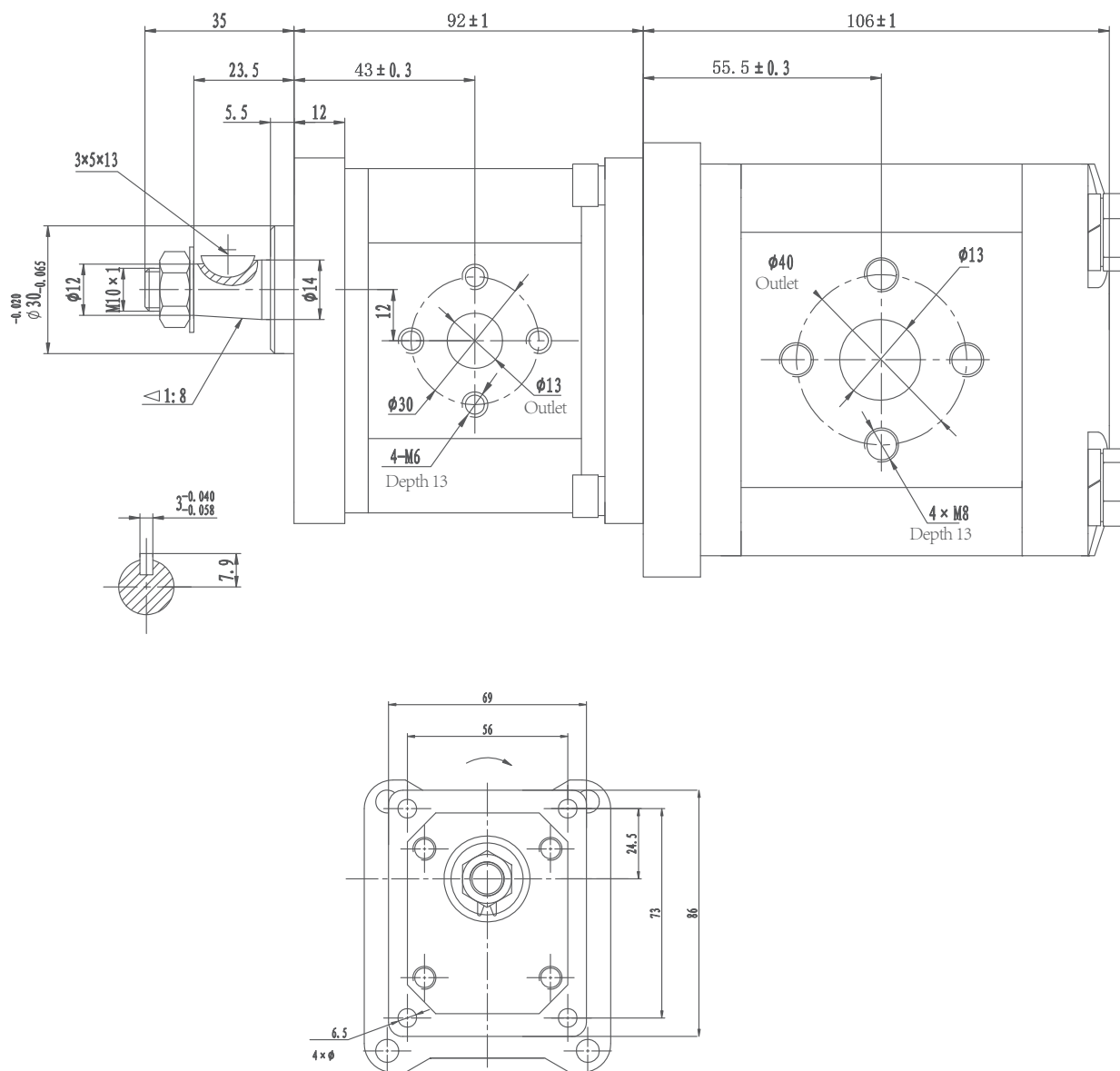

**2ADPF\*\*/\*\*DL\*\*F32D9\***

Displacement(ml/r)	4	6	8	10	12	14	16	18	20	23	28	30
L3/L4	50.5	54.0	57.0	60.0	63.0	66.0	69.0	72.5	76.0	80.5	88.0	91.0
L	96	98	102	104	108	110	114	117	120	123	133	136
L1	43.3	45.0	46.5	48.0	50.0	51.0	53.0	55.0	56.0	58.0	63.0	64.0

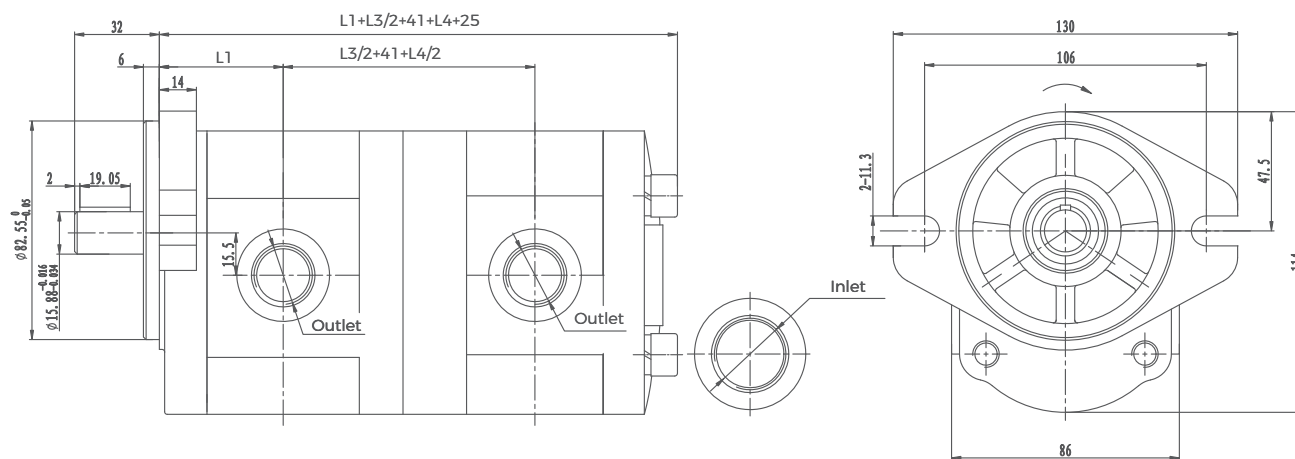
**Dimensions**

**2ADPF\*\*/\*\*DF\*\*T24S7\***

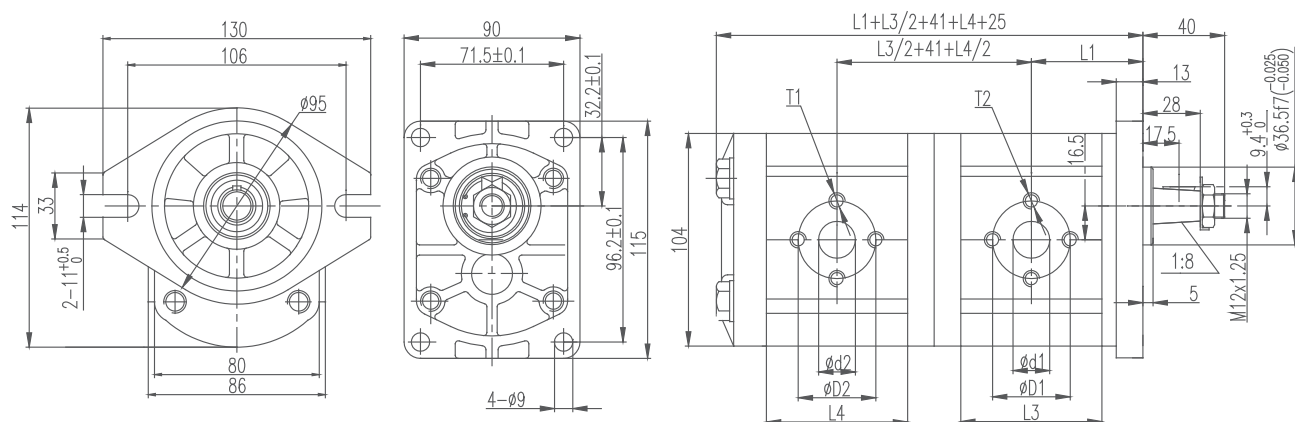
Displacement(ml/r)	4	6	8	10	12	14	16	18	20	23	28	30
L3/L4	50.5	54.0	57.0	60.0	63.0	66.0	69.0	72.5	76.0	80.5	88.0	91.0
L	96	98	102	104	108	110	114	117	120	123	133	136
L1	43.3	45.0	46.5	48.0	50.0	51.0	53.0	55.0	56.0	58.0	63.0	64.0

**Dimensions**

**2ADPF\*\*/\*\*DL\*\*S18D9\***



Displacement(ml/r)	4	6	8	10	12	14	16	18	20	23	28	30
L3/L4	50.5	54.0	57.0	60.0	63.0	66.0	69.0	72.5	76.0	80.5	88.0	91.0
L	96	98	102	104	108	110	114	117	120	123	133	136
L1	43.3	45	46.5	48.0	50.0	51.0	53.0	55.0	56.0	58.0	63.0	64.0

**Dimensions**

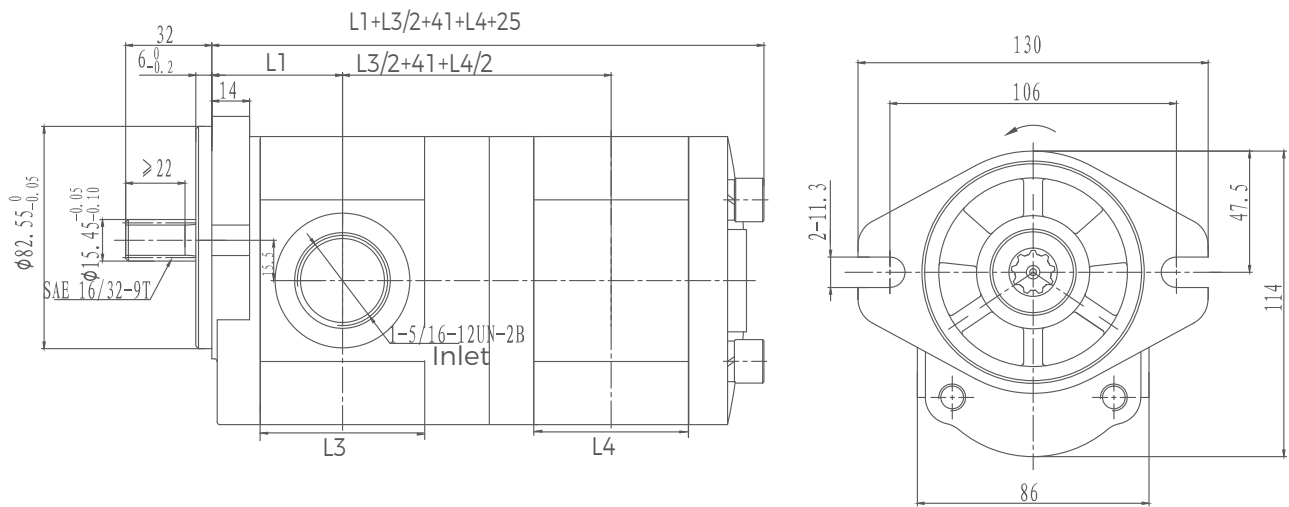

**2ADPF\*\*/\*\*DF\*\*T10S8\***

Displacement(ml/r)	4	6	8	10	12	14	16	18	20	23	28	30
L3/L4	50.5	54.0	57.0	60.0	63.0	66.0	69.0	72.5	76.0	80.5	88.0	91.0
L	96	98	102	104	108	110	114	117	120	123	133	136
L1	43.3	45.0	46.5	48.0	50.0	51.0	53.0	55.0	56.0	58.0	63.0	64.0

**Dimensions**

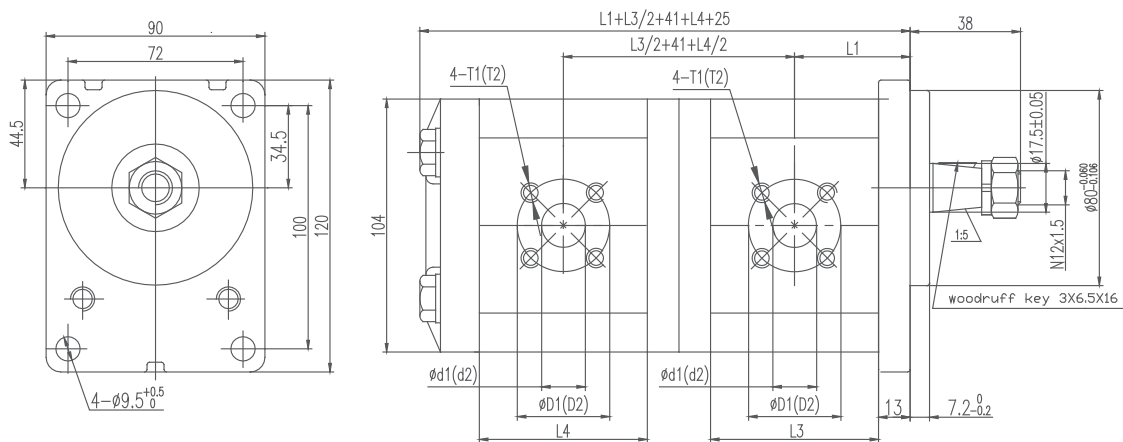



## 2ABDPF23/5DLJ40S341-T-W-D-TLT



Model	Displacement (ml/r)	Pressure(bar)		Speed(r/min)			Inlet	Outlet
		Rated	Max.	Rated	Max.	Min.		
2ABDPF23/5DLJ40S341-T-W-D-TLT	23/5	200	250	2000	3000	800	1-5/16-12UN	1-1/16-12UN 3/4-16UNF

### Dimensions

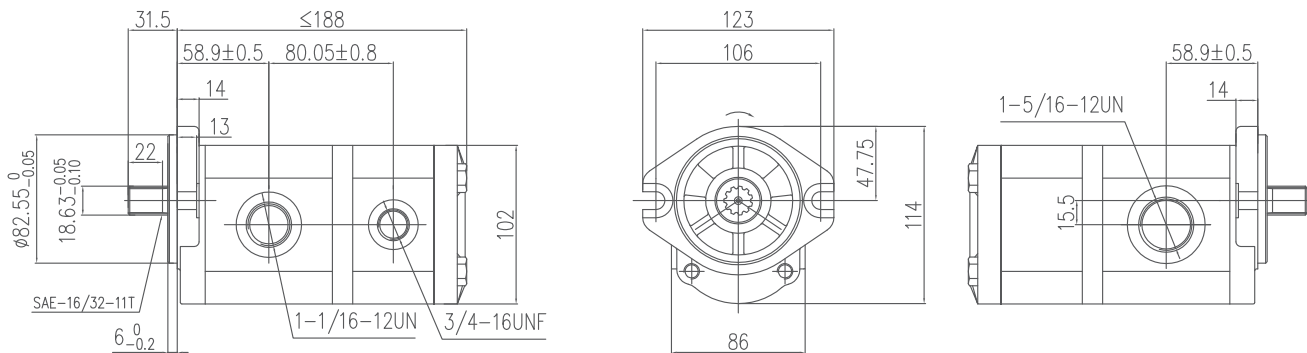

## 2/1ASDPG6.5/3.2DLJ113S342-D

Model	Displacement (ml/r)	Pressure(bar)		Speed(r/min)			Inlet	Outlet
		Rated	Max.	Rated	Max.	Min.		
2/1ASDPG6.5/3.2DLJ113S342-D	6.5/3.2	200	250	2000	3500	800	1-5/16-12UN 9/16-18UNF	7/8-14UNF 9/16-18UNF

### Dimensions

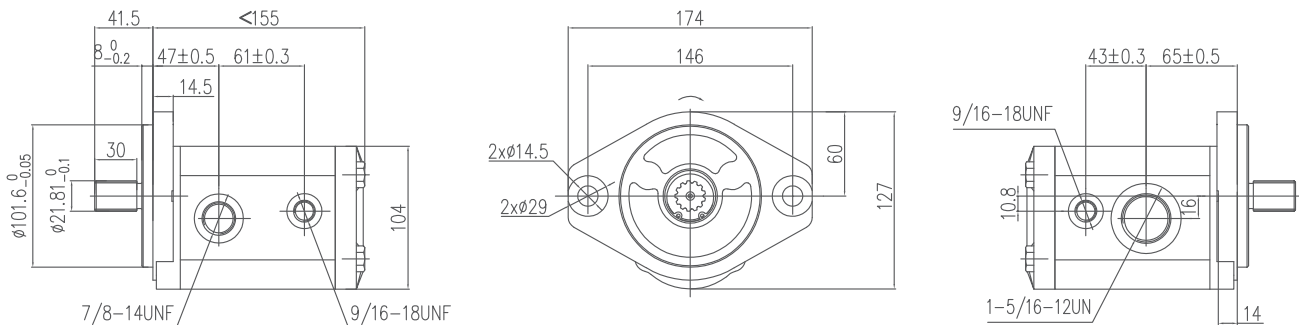

2ATPF\*\*/\*\*/\*\*TF02\*\*\*



Model	Displacement (ml/r)	Pressure(bar)		Speed(r/min)			L (mm)	L1 (mm)	Inlet			Outlet		
		Rated	Peak	Rated	Max.	Min.			D1	d1	T1	D2	d2	T2
2APF04F60*	4	200	250	2000	3500	500	87.9	42.2	40	15	M6	30	15	M6
2APF06F60*	6	200	250	2000	3500	500	91.1	43.8						
2APF08F52*	8	200	250	2000	3500	500	94.3	45.4						
2APF10F52*	10	200	250	2000	3500	500	97.5	47.0						
2APF12F52*	12	200	250	2000	3500	500	110.7	48.6						
2APF14F52*	14	200	250	2000	3500	500	114.0	50.2						
2APF16F52*	16	200	250	2000	3500	500	109.5	51.2	40	20	M6	30	15	M6
2APF18F52*	18	200	250	2000	3500	500	113.0	52.8						
2APF20F52*	20	200	250	2000	3500	500	116.5	55.3						
2APF23F52*	23	200	250	2000	3000	500	121.5	56.9						
2APF25F52*	25	200	250	2000	3000	500	124.7	58.5						

Dimensions

2TPF\*\*/\*\*/\*\*TF02T2008\*

Option: 2TPF\*\*/\*\*/\*\*TF02F63D9\*

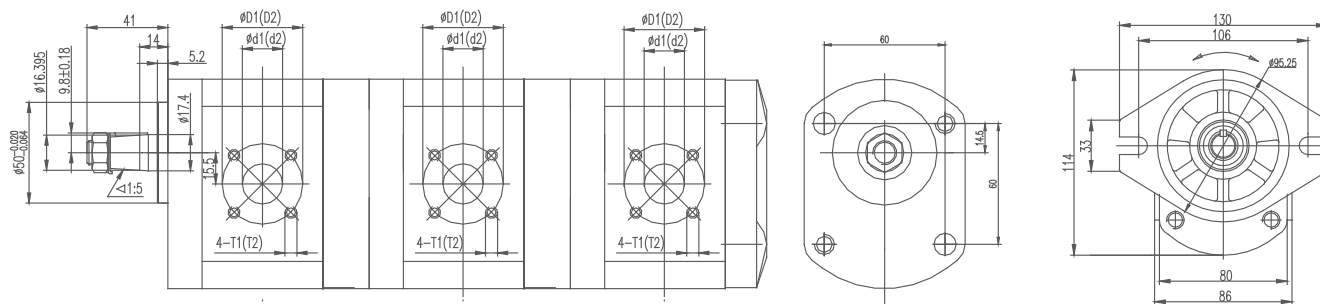

Ordering code: 2APF\*\*F52T2008\*-A

Ordering code: 2APF\*\*F52\*-M

Ordering code: 2APF\*\*F52\*-B

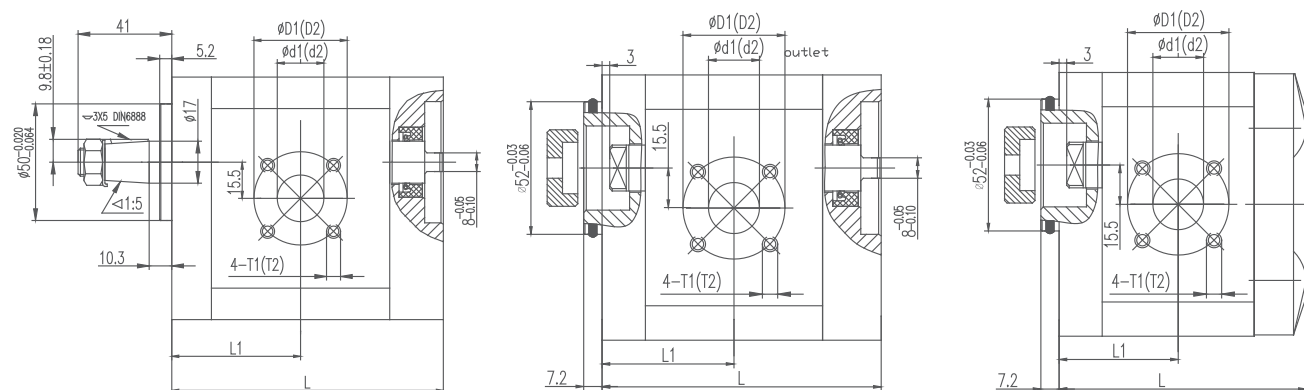

## 2ATPF10/5/5TLJ04S46D9



Model	Displacement (ml/r)	Pressure(bar)		Speed(r/min)			Inlet	Outlet
		Rated	Peak	Rated	Max.	Min.		
2ATPF10/5/5TLJ04S46D9	10/5/5	200	250	2500	3000	500	1-5/16-12UN-2B 2UN-2B	3/4-16UNF -2B

### Dimensions

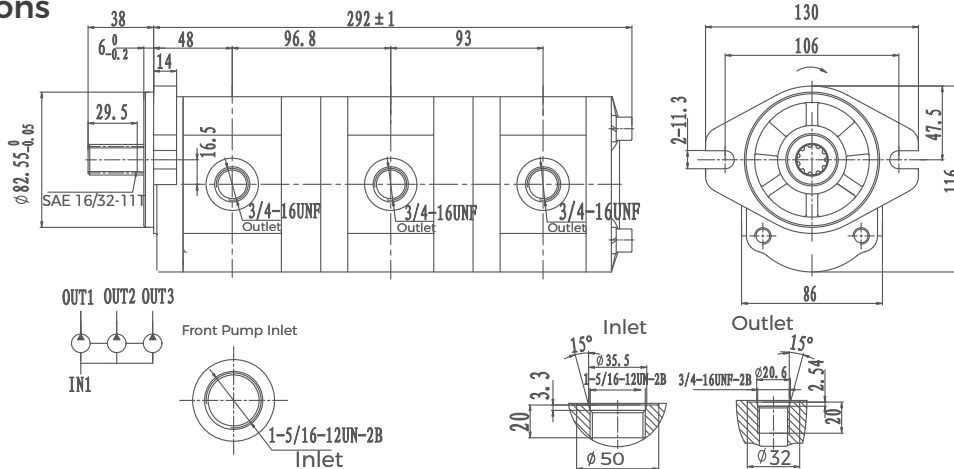

## 2ATPF14/14/8TL28S35D9-C

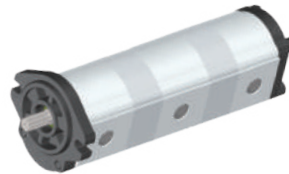

Model	Displacement (ml/r)	Pressure(bar)		Speed(r/min)			Inlet	Outlet
		Rated	Peak	Rated	Max.	Min.		
2ATPF14/14/8TL28S35D9-C	14/14/8	160	200	2000	3000	500	NPT3/4	NPT1/2

### Dimensions

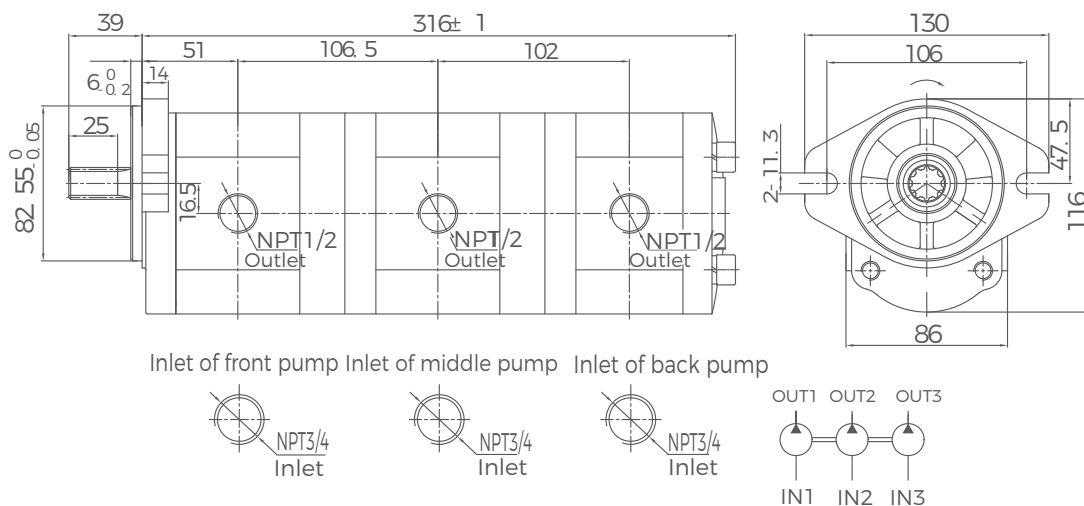

**2AFP4/4/4/4FLJ\*\*F63D9**



Model	Displacement (ml/r)	Pressure(bar)		Speed(r/min)			Inlet	Outlet
		Rated	Peak	Rated	Max.	Min.		
2AFP4/4/4/4FLJ**F63D9	4/4/4/4	200	250	2000	3000	500	1-1/16-1 2UNF-2B	7/8-1 4UNF-2B

**Dimensions**

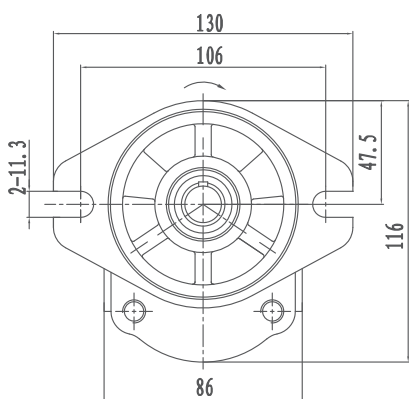
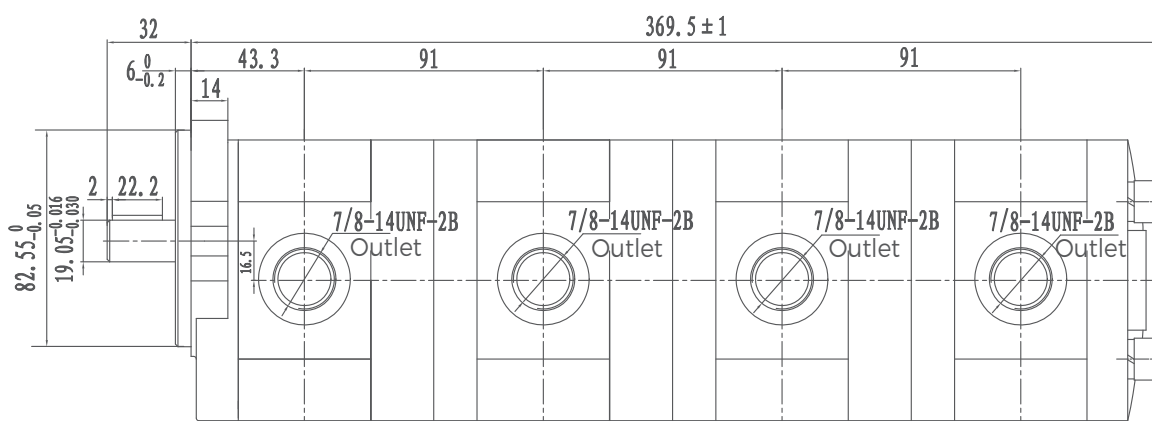

### 3/2ADPF25/08DF129T40S14\*



Model	Displacement (ml/r)	Pressure(bar)		Speed(r/min)		
		Rated	Peak	Rated	Max.	Min.
3/2ADPF25/08DF129T40S14*	25/08	200	250	2000	3000	500

### Dimensions

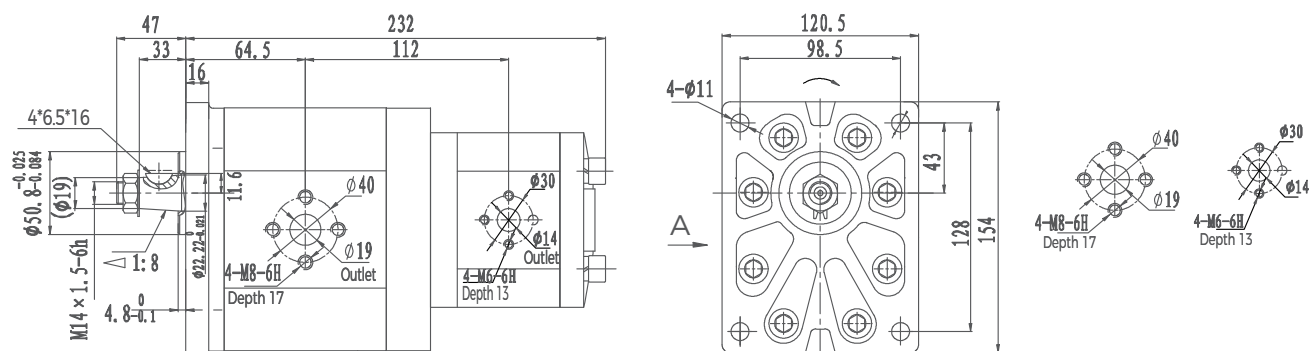

### 3/2ADPF32/23DF128S70D12\*

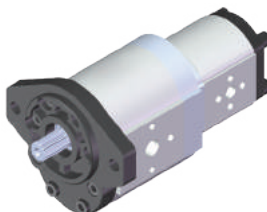

Model	Displacement (ml/r)	Pressure(bar)		Speed(r/min)		
		Rated	Peak	Rated	Max.	Min.
3/2ADPF32/23DF128S70D12*	32/23	200	250	2000	3000	500

### Dimensions

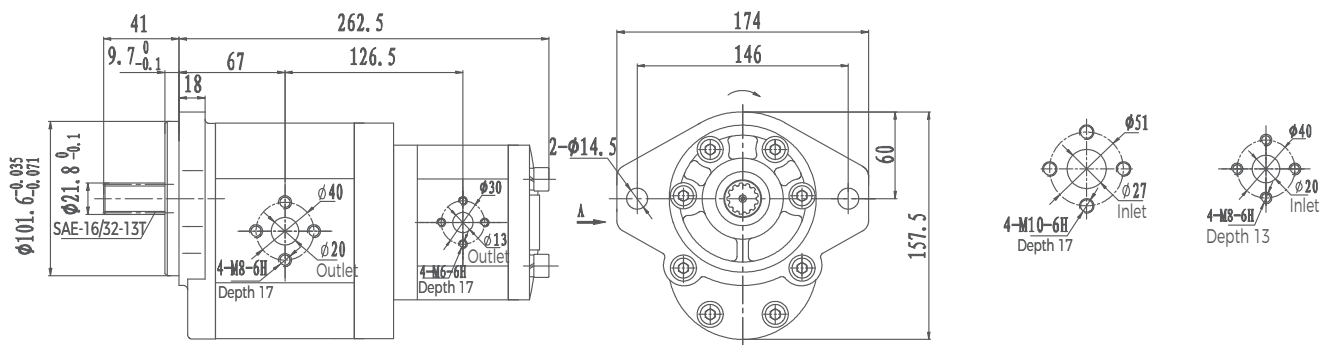

**3ADPF\*\*/DL\*\*T40S14\***



Displacement(ml/r)	22	26	34	39	43	51	60	70
L3 / L4	80.0	83.0	88.5	92.5	95.0	101.0	107.5	114.5
L	128.5	131.5	137.0	141.0	143.5	149.5	156.0	163.0
L1	65.5	67.0	69.8	71.8	73.0	76.0	79.3	82.8

**Dimensions**

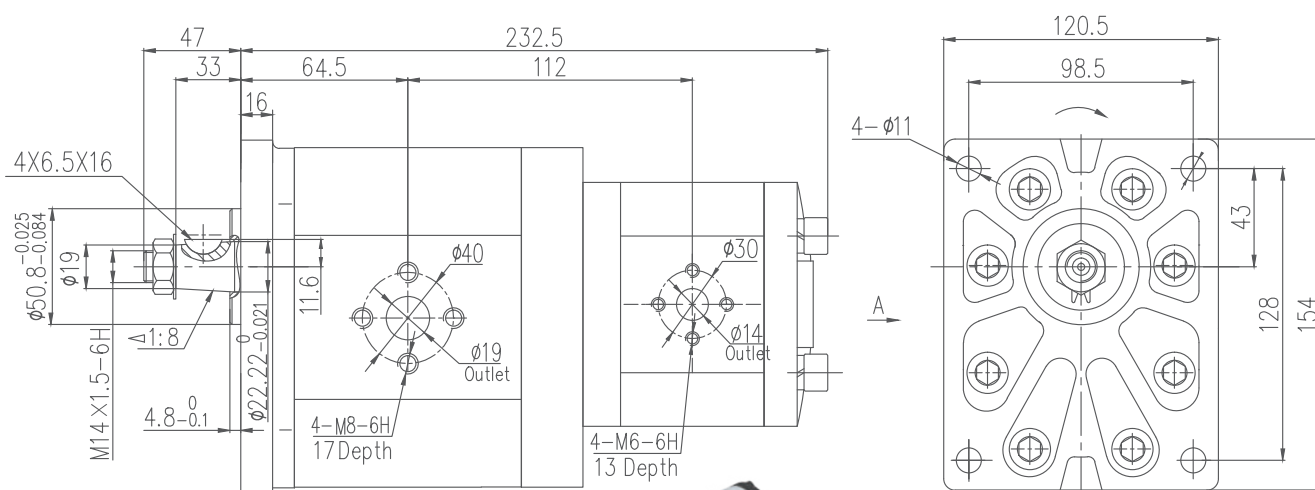

**3ADPF\*\*/DL\*\*S70D12\*\*\***

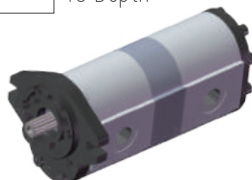

Displacement(ml/r)	22	26	34	39	43	51	60	70
L3 / L4	80.0	83.0	88.5	92.5	95.0	101.0	107.5	114.5
L	128.5	131.5	137.0	141.0	143.5	149.5	156.0	163.0
L1	65.5	67.0	69.8	71.8	73.0	76.0	79.3	82.8

**Dimensions**

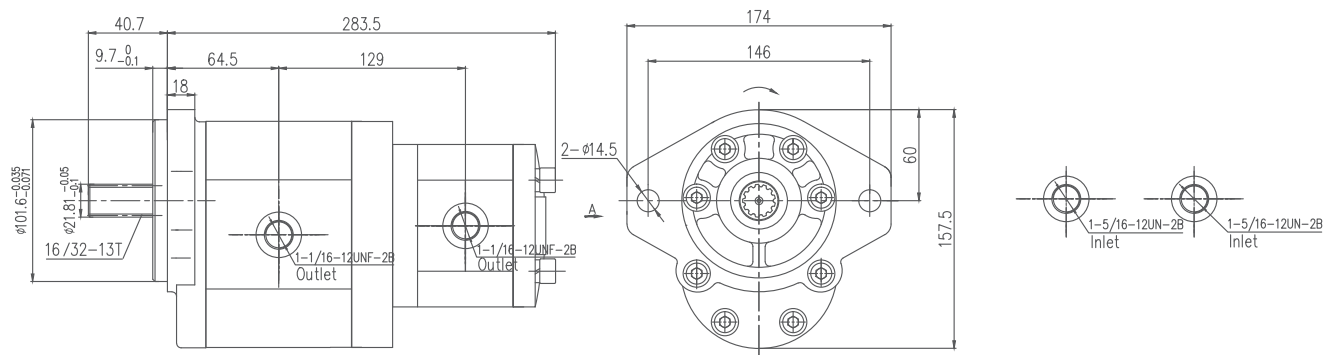

## 3ATPF\*\*TL\*\*S70D12\*

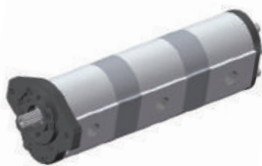

滚滚长江东逝水

Model	Displacement (ml/r)	Pressure(bar)		Speed(r/min)			L (mm)	L1 (mm)	L2 (mm)	B2 (mm)	ØD1 (mm)	T1 (mm)	L3 (mm)	B3 (mm)	ØD2 (mm)	T2 (mm)
		Rated	Peak	Rated	Max.	Min.										
3ATPF**TL**S70D12*	22	200	250	2000	3000	400	130.3	65.3	52.4	26.2	27	3/8 16- UNC -2B	26.2	47.6	19	3/8 16- UNC -2B
3ATPF**TL**S70D12*	26	200	250	2000	3000	400	133.3	66.8								
3ATPF**TL**S70D12*	34	200	250	2000	3000	400	138.8	69.6								
3ATPF**TL**S70D12*	39	200	250	2000	3000	400	142.8	71.6								
3ATPF**TL**S70D12*	43	200	250	2000	2800	400	145.3	72.8								
3ATPF**TL**S70D12*	51	200	250	2000	2400	400	151.3	75.8								
3ATPF**TL**S70D12*	60	180	230	1500	2800	400	157.8	79.1	58.7	28.4	33	7/16 14- UNC -2B	26.2	52.4	27	
3ATPF**TL**S70D12*	70	180	200	1500	2500	400	164.8	82.5								
3ATPF**TL**S70D12*	78	160	200	1500	2300	400	171.0	85.0								
3ATPF**TL**S70D12*	89	140	180	1500	2000	400	176.0	88.0								

## Dimensions

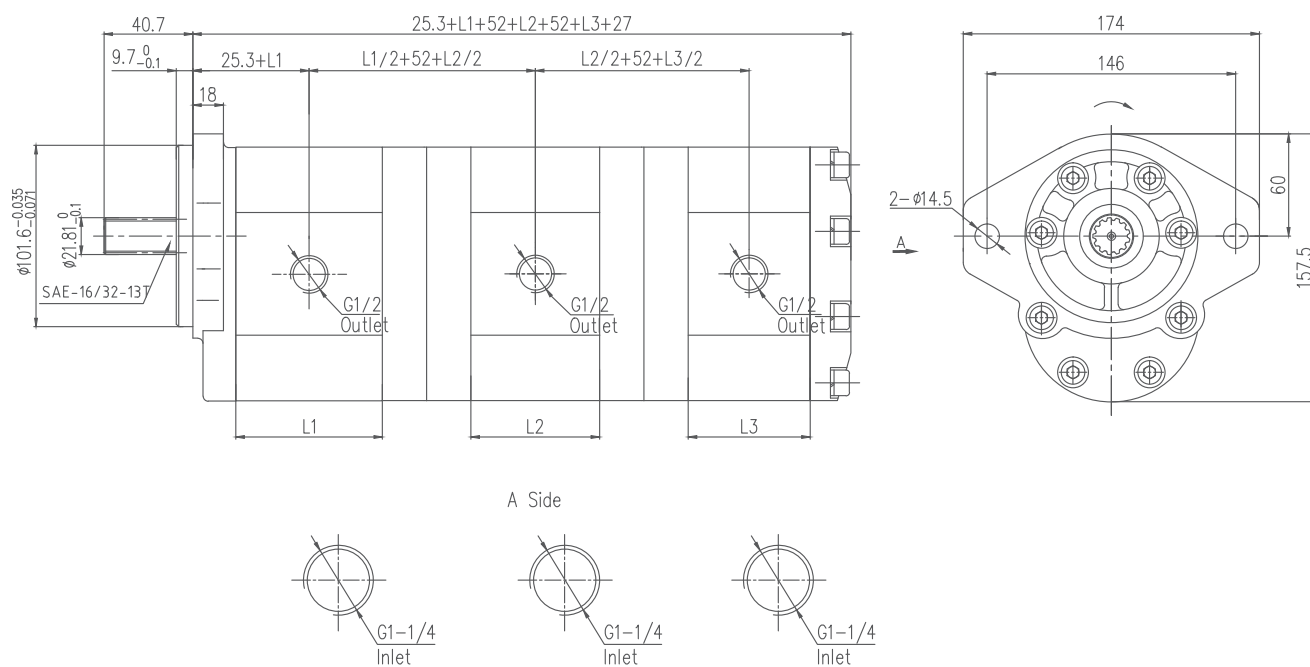

## Application Guide of Tandem Pump Connection - Assemble Step

### 2ABDPF\*\*F\*\*\*\*-TS Only for Tandem Pump or Triple Pump

Step 1 2ABPF-F\*\*\*\*-TSF

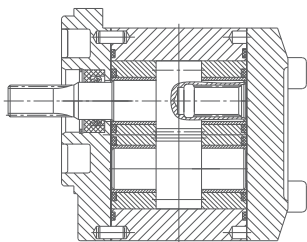

Step 2 2ABPF-F\*\*\*\*-TSM

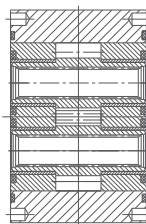

Step 3 2ABPF-F\*\*\*\*-TSR

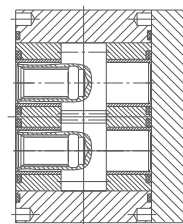

Step 4 Add kit 2ABPF-TS-K

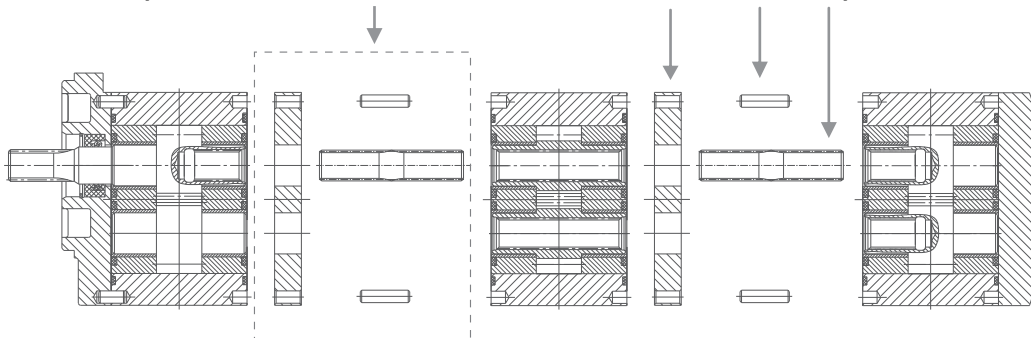
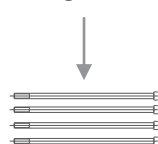

Plate Pin Spline

Long Bolts

Step 5 Tighten bolt 4 × M10/70Nm



To remove 4 × M10  
short bolt and stat using

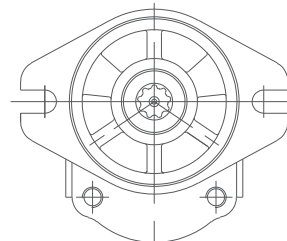
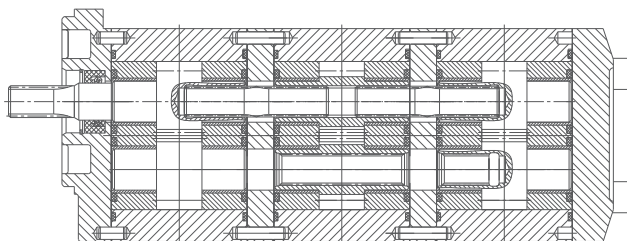



## Exploded View

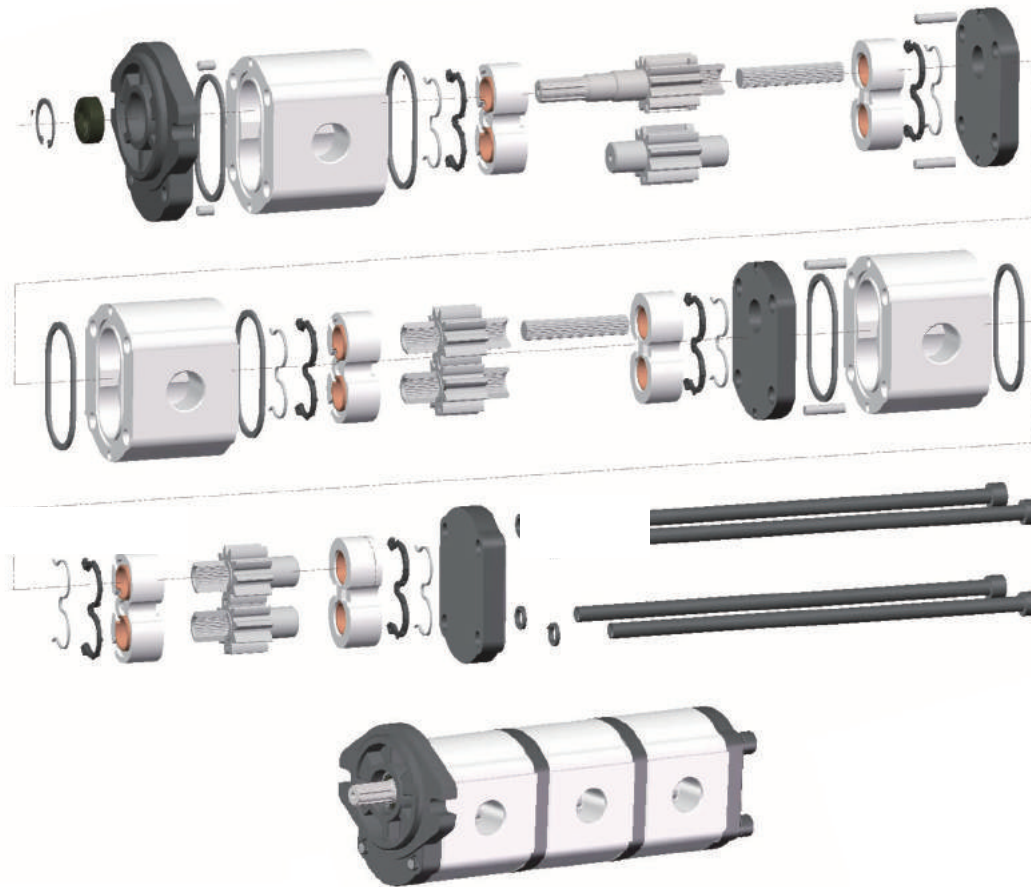

## Ordering Code

No.	Name	Order Code	Quantity	Notes
1	Gear Pump	2ABPF**F****-TSF	1	Front Pump
2	Gear Pump	2ABPF**F****-TSM	1	Middle Pump
3	Gear Pump	2ABPF**F****-TSR	1	Rear Pump
4	Kit	2ABPF-TS-K1	1	Used in Double Pump or Triple Pump
4.1	Pin	2ABPF-TS-KP	2	
4.2	Plate	2ABPF-TS-KPL	1	
4.3	Spline	2ABPF-TS-KSP	1	
5	Bolt		4	According to the displacement

**2BDPF\*\*F\*\*\*\*\*-Can Be Used As Single Pump**

**STEP 1 2BPF\*\*F\*\*\*\*\*-TK**

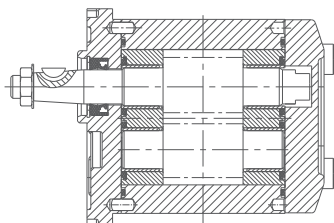

**STEP 2 2BPF\*\*F\*\*\*\*\*-TK**

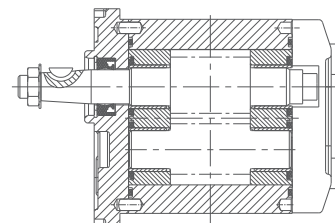

**Step 3 Add kit 2BPF-TK-K**

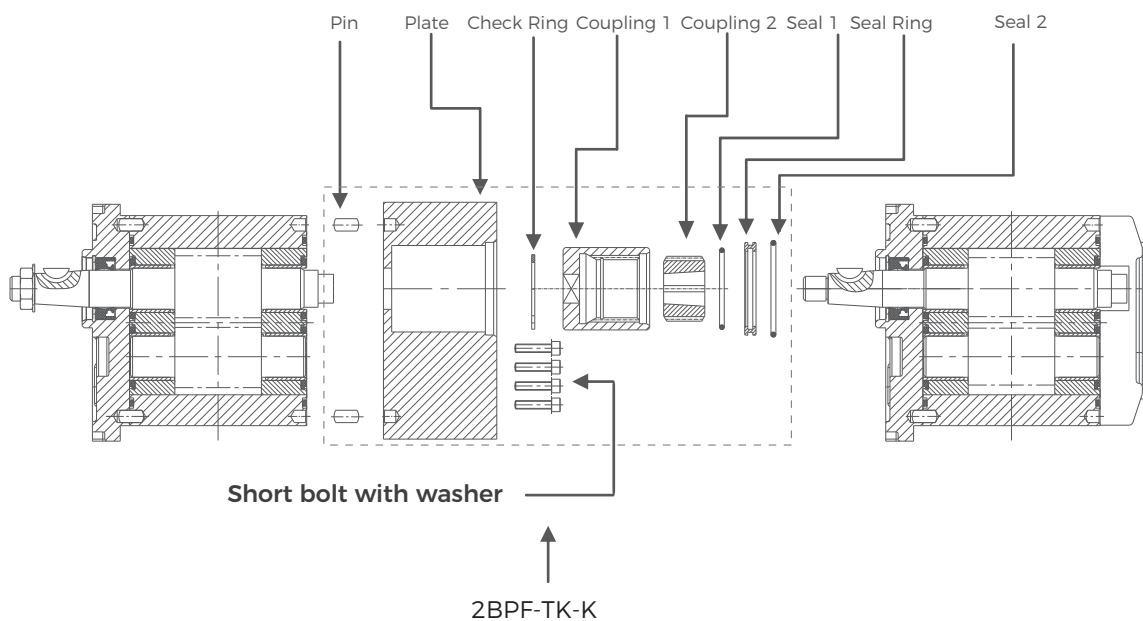

**Step 4 Tighten bolt 4 × M8/40Nm**

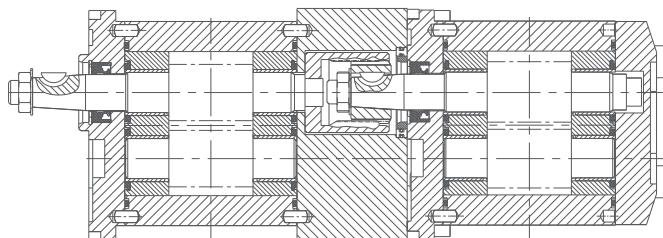

## Exploded View

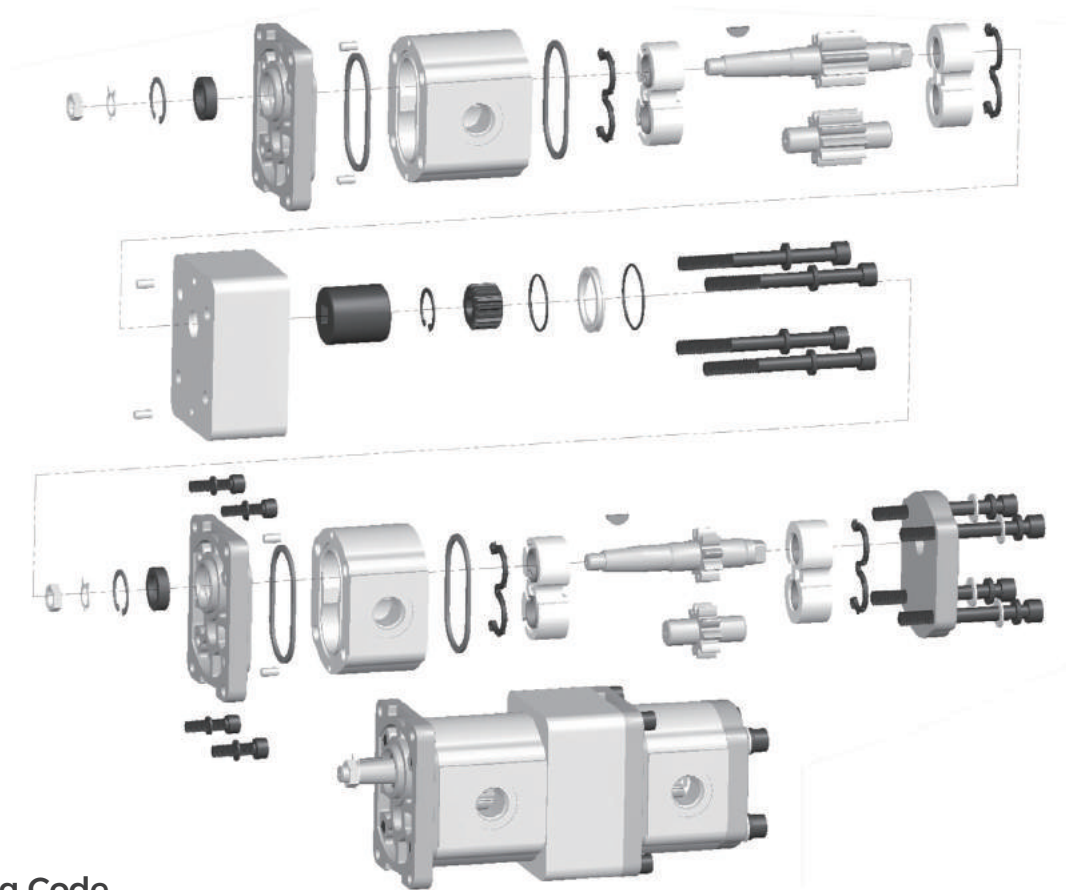

## Ordering Code

No.	Name	Order Code	Quantity	Notes
1	Gear Pump	2BPF**F****-TK	1	Front Pump
2	Gear Pump	2BPF**F****-TK	1	Rear Pump
3	Kit	2BPF-TK-K	1	
3.1	Pin	2BPF-TK-KP	2	Used in 2BPF-TK-K
3.2	Plate	2BPF-TK-KBL	1	Used in 2BPF-TK-K
3.3	Check Ring	2BPF-TK-KBL	1	Used in 2BPF-TK-K
3.4	Coupling 1	2BPF-TK-KC1	1	Used in 2BPF-TK-K
3.5	Coupling 2	2BPF-TK-KC2	1	Used in 2BPF-TK-K
3.6	Seal 1	2BPF-TK-KS1	1	Used in 2BPF-TK-K
3.7	Seal 2	2BPF-TK-KS2	1	Used in 2BPF-TK-K
3.8	Seal Ring	2BPF-TK-KSR	1	Used in 2BPF-TK-K
3.9	Bolt with Washer	2BPF-TK-KB	4	Used in 2BPF-TK-K

**2ABDPF\*\*F\*\*\*\*-XK Only for Tandem Pump**

**Step 1 2ABPF\*\*F\*\*\*\*-XKF**

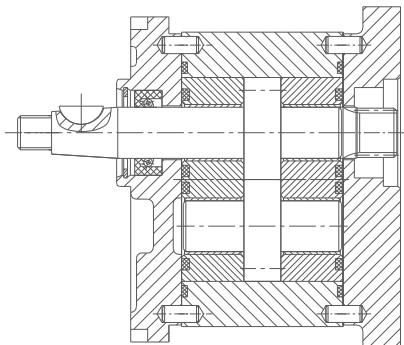

**Step 2 2ABPF\*\*F\*\*\*\*-XKR**

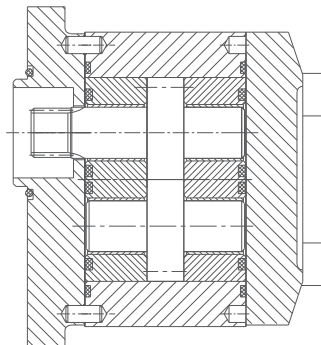

**Step 3 Add 2ABPF-XK-K ( Nuts 4×M10 / Washer 4×ϕ11 / Coupling 1/ Bolt 4×M10 )**

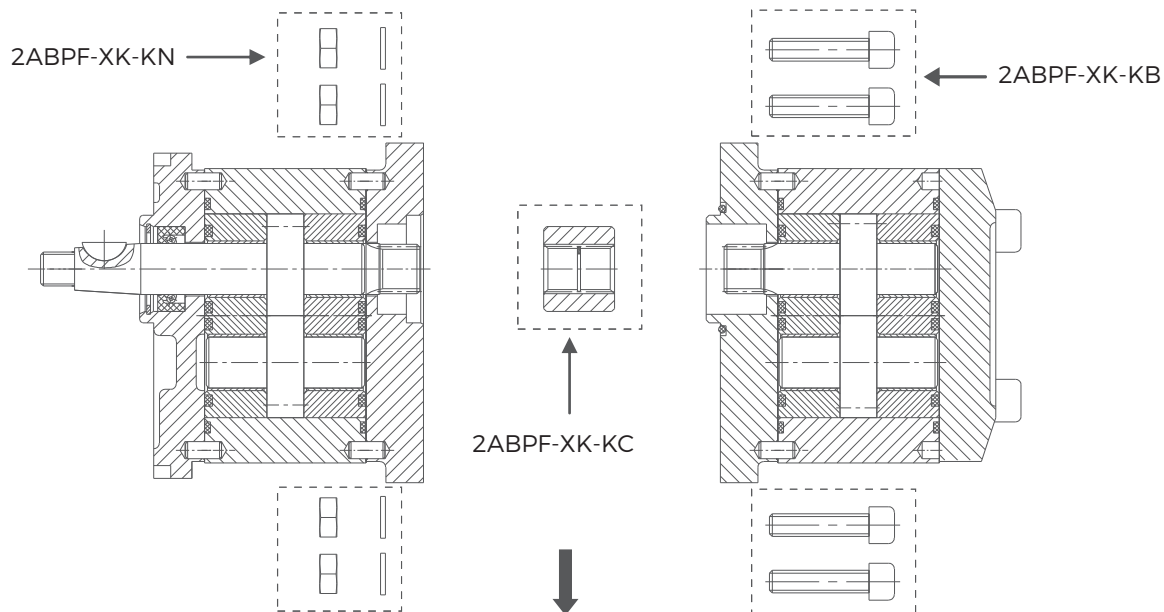

**Step 4 Tighten bolt 4 × M8/40Nm**

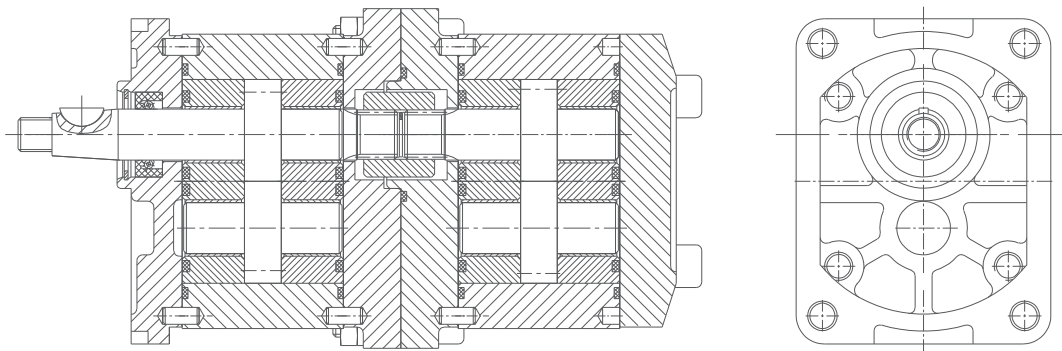

## Exploded View

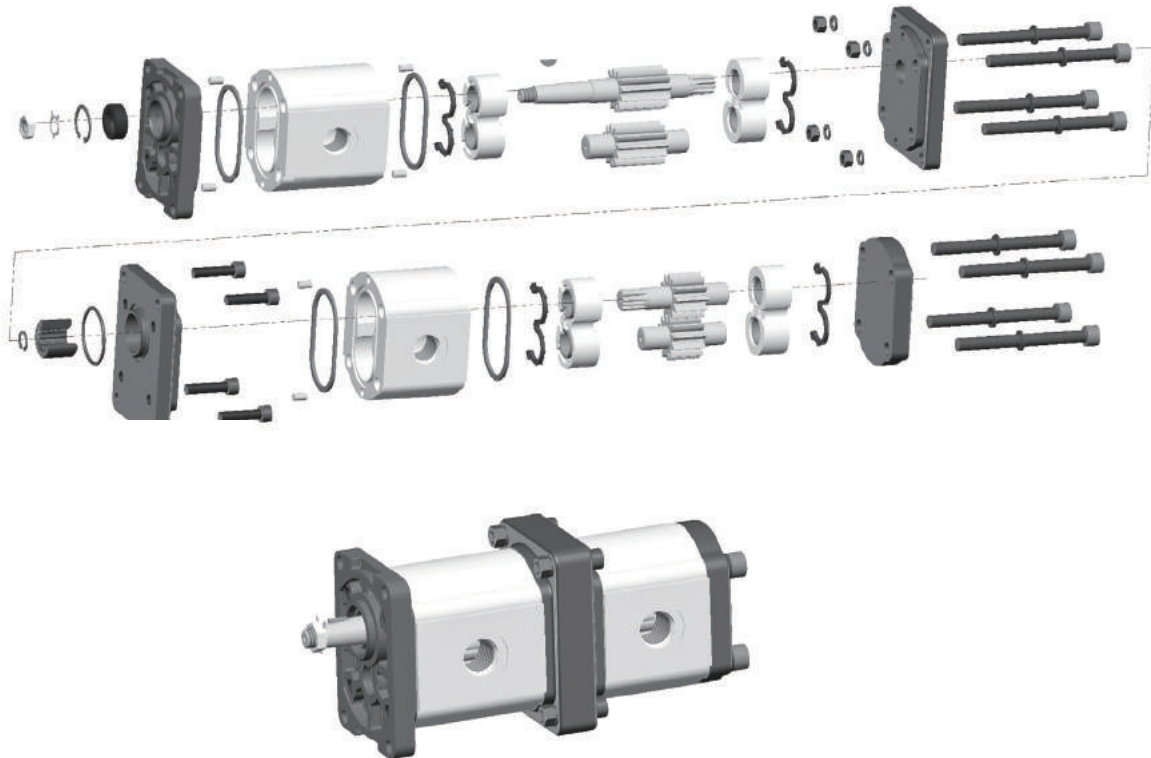

## Ordering Code

No.	Name	Order Code	Quantity	Notes
1	Gear Pump	2ABPF**F****-XKF	1	Front Pump
2	Gear Pump	2ABPF**F****-XKR	1	Rear Pump
3	Kit	2ABPF-XK-K	1	Nuts × 4 / Whsher × 4 / Coupling×1 / Bolt × 4
3.1	NuT and washer	2ABPF-XK-KN	4	Used in 2ABPF-XK-K
3.2	Coupling	2ABPF-XK-KC	1	Used in 2ABPF-XK-K
3.3	Bolt	2ABPF-XK-KB	4	Used in 2ABPF-XK-K

## 2ABDPF\*\*F\*\*\*\*-FK Can Be Used As Single Pump

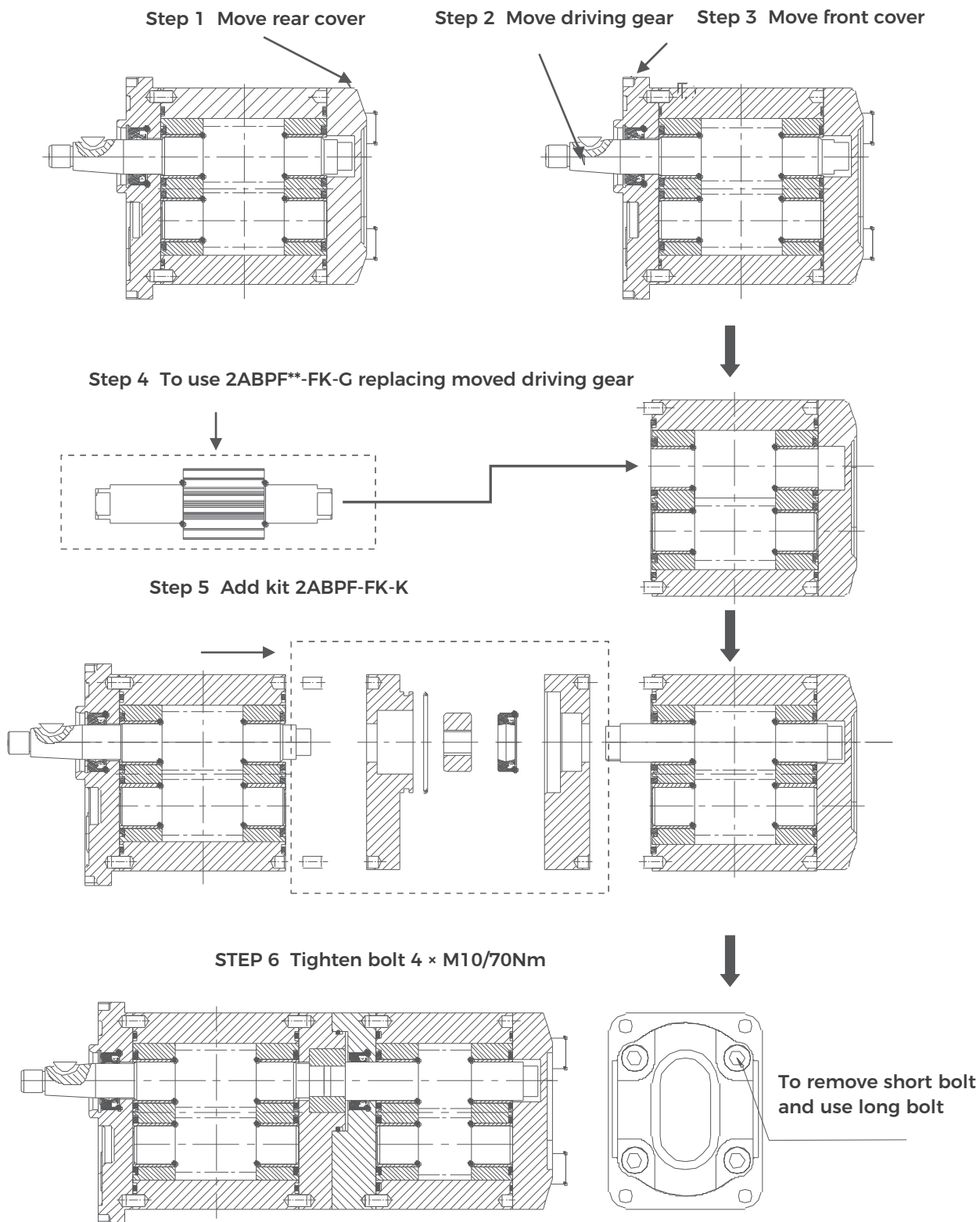

## Exploded View

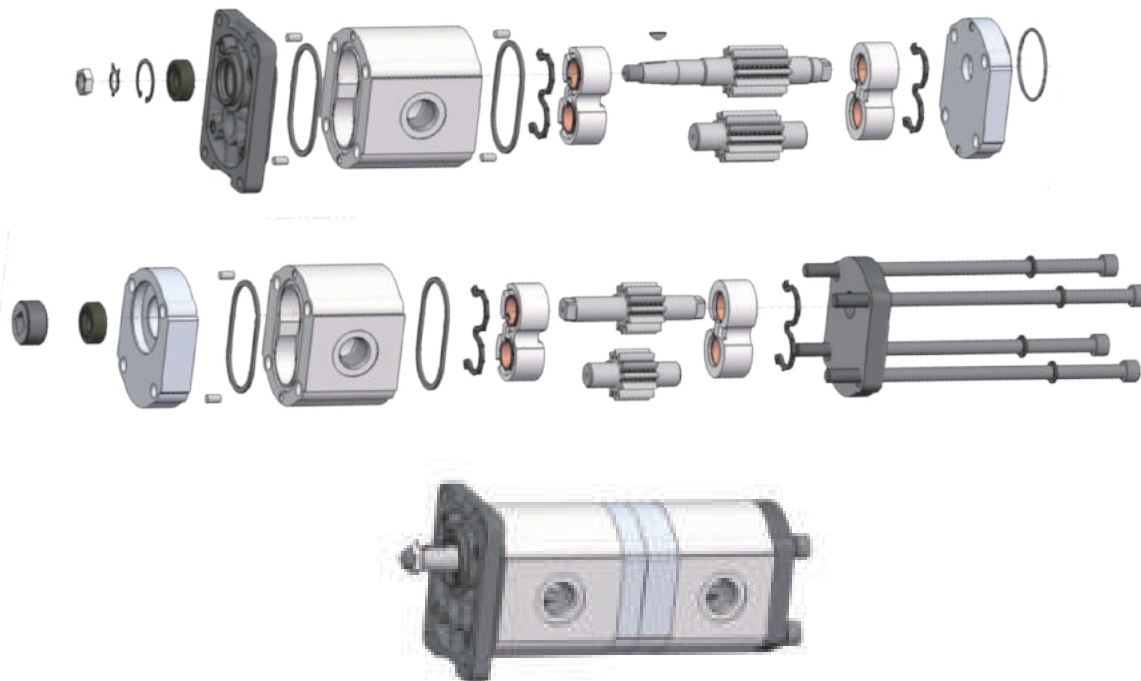

## Ordering Code

No.	Name	Order Code	Quantity	Notes
1	Gear Pump	2ABPF**F****-TK	1	Front Pump
2	Gear Pump	2ABPF**F****-TK	1	Rear Pump
3	Gear	2ABPF**-FK-G	1	**—cc/r
4	Kit	2ABPF-FK-K	1	
4.1	Pin	2ABPF-FK-KP	2	Used for 2ABPF-FK-K
4.2	Plate 1	2ABPF-FK-KPL1	1	Used for 2ABPF-FK-K
4.3	Seal	2ABPF-FK-KS	1	Used for 2ABPF-FK-K
4.4	Coupling	2ABPF-FK-KC	1	Used for 2ABPF-FK-K
4.5	Shaft Seal	2ABPF-FK-KSS	1	Used for 2ABPF-FK-K
4.6	Plate 2	2ABPF-FK-KPL2	1	Used for 2ABPF-FK-K
5	Bolt		4	According to the displacement



## Ordering Code

<b>1</b>	<b>E</b>	<b>P</b>	<b>F</b>	<b>73</b>	<b>L01</b>	<b>F75</b>	<b>D9</b>	<b>L-</b>	<b>SS</b>	<b>F</b>
a	b	c	d	e	f	g	h	i	j	k

Ⓐ 1=Group

1, 2, 2.5, 3, 3.5, 4

Ⓑ E/Y/C=Cast Iron pump

Ⓒ Function

P=Gear pump

D=Double pump

T=Triple pump

Ⓓ Pressure rate

E=160bar

F=200bar

G=250bar

Ⓔ Displacement=1.6 ~ 199cc/r

Ⓕ L01=Line ports

Ⓖ F75=Drive shaft

Ⓗ D9=Front cover

Ⓘ Rotation

R=CW

L=CCW

B=Bi-directional

Ⓙ Ports combination

SS=Side inlet and side outlet

SB=Side inlet and back outlet













BS=Back inlet and side outlet

BB=Back inlet and back outlet

Ⓚ Seal

F=FKM seal

Omit=NBR seal

Ⓕ Line ports Inlet/Outlet			Ⓖ Drive shaft			Ⓗ Front cover		
LJ35	3/4-16UNF-2B 9/16-18UNF-2B		O9	Oblate shaft Ø4.37mm x 8		S2	4-groove mounting 50.8 x 50.8mm	
L00	G1 G1		S70	Splined shaft 13 teeth 21.81mm		D9	2-groove mounting Ø106mm	
F97	52.4 x 26.2,M10, Ø25 47.6 x 22.2,M10, Ø19		F75	Flat keyed shaft Ø19.05mm		D14	6-hole mounting 89.81 mm,146.05mm	
F104	52.4 x 26.2,M10,Ø25 52.4 x 26.2,M10,Ø25		S57	Splined shaft 11teeth 18mm		SP9	4-hole mounting Ø113 x 113mm	



## 1EPF\*\*L35O9S2\*SS-YD



### With Relief Valve

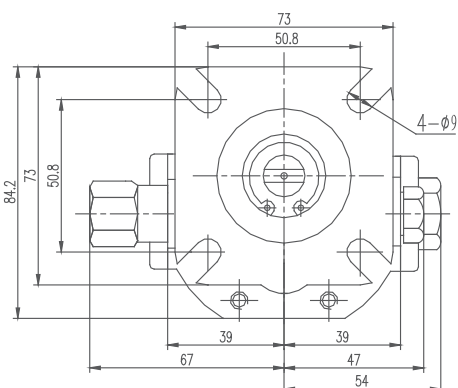
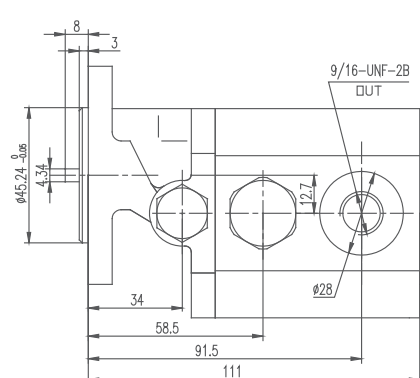

Model	Displacement (ml/r)	Pressure(bar)		Speed(r/min)			Port	
		Rated	Peak	Rated	Max.	Min.	Inlet	Outlet
1EPF1.6L35O9S2SS-YD	1.6	160	200	2000	4500	500	3/4-16UNF -2B	9/16-18UNF -2B
1EPF2.7L35O9S2SS-YD	2.7	160	200	2000	4500	500		
1EPF4.1L35O9S2SS-YD	4.1	160	200	2000	4500	500		
1EPF6.1L35O9S2SS-YD	6.1	160	200	2000	4500	500		

## Dimensions



 clockwise: omit  
 counter clockwise: L

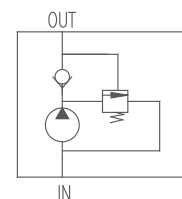
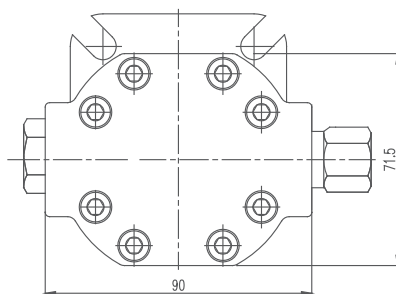
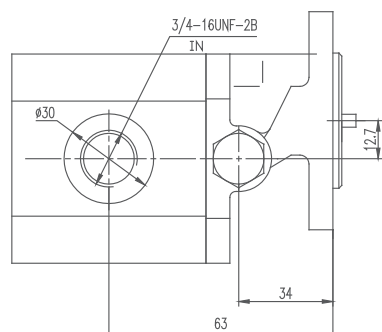

**2YBDPF\*\*DF\*\*S57S12\***



Model	Displacement(ml/r)		Pressure(bar)				Speed(r/min)		
			Front Pump		Rear Pump				
	Front Pump	Rear Pump	Rated	Peak	Rated	Peak	Rated	Max.	Min.
2YBDPF20/10DF54S57S12*	20	10	200/250	250/300	200/250	250/300	2500	3000	800

**Dimensions**

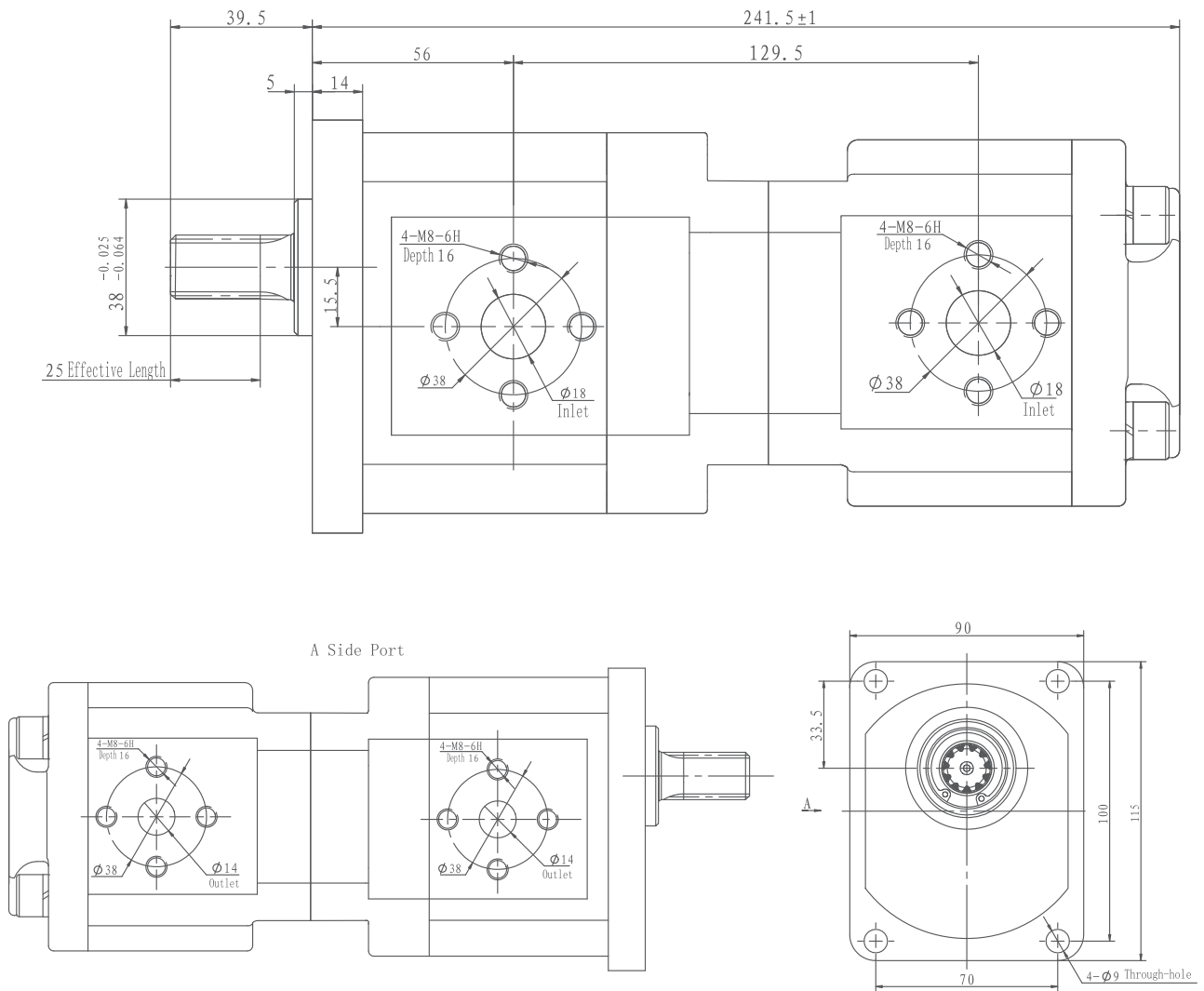

## 2.5YPF25F97F75D9\*



Model	Displacement (ml/r)	Pressure(bar)		Speed(r/min)			Inlet			Outlet		
		Rated	Peak	Rated	Peak	Min.	L1x B1	T1	Ød1	L1x B2	T2	Ød2
2.5YPF25F97F75D9*	25	250	280	1500	2500	500	52.4 X 26.2	M10	Ø25	47.6 X 22.2	M10	Ø19

## Dimensions

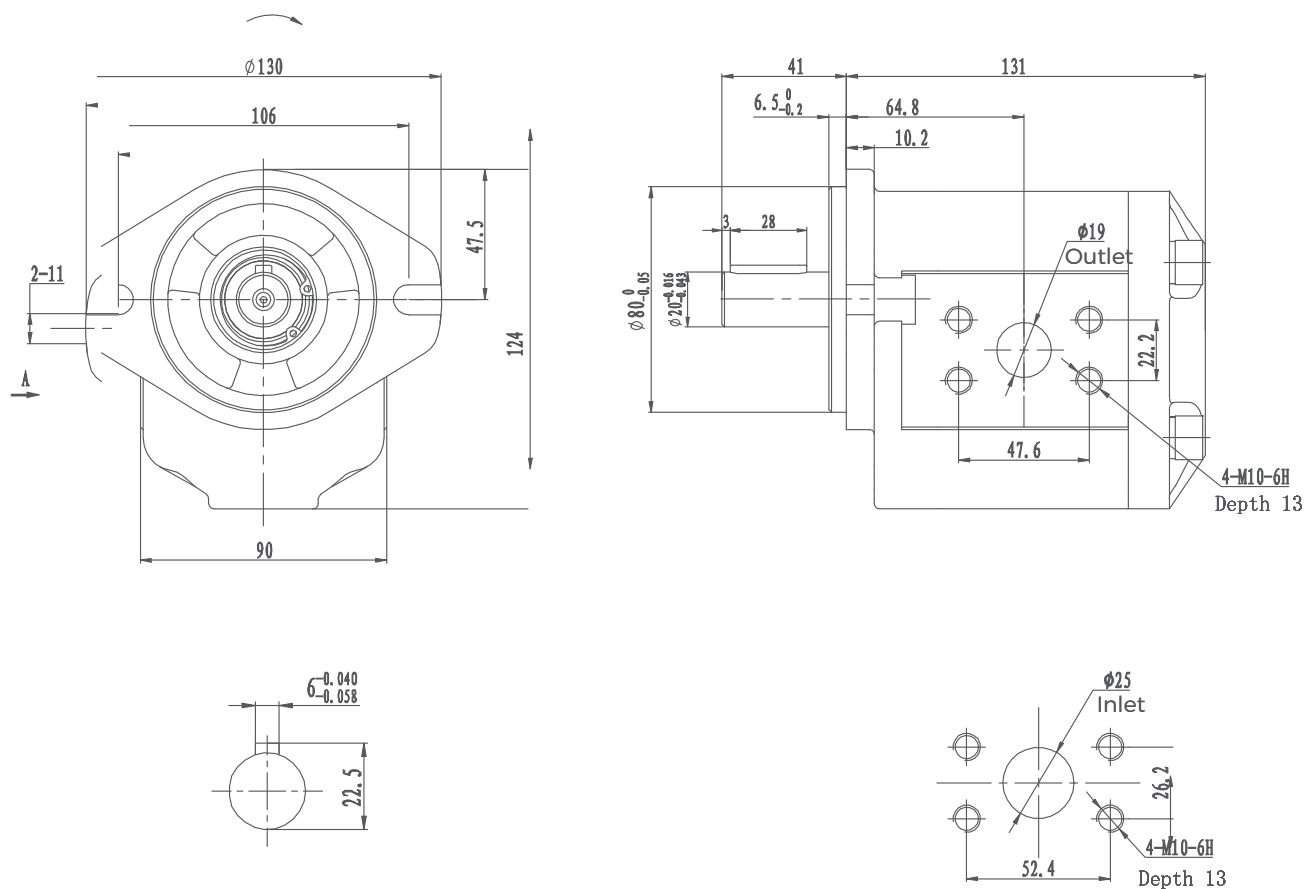

**2.5EPF\*\*L\*\*F104D11-O\***

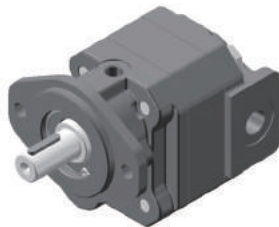

Model	Displacement (ml/r)	Pressure(bar)		Speed(r/min)			L(mm)	L1(mm)
		Rated	Peak	Rated	Max.	Min.		
25EPF1016L**F104D11-O*	10.16	210	250	2000	3000	600	137.0	112.0
25EPF1523L**F104D11-O*	15.23	210	250	2000	3000	600	143.5	118.5
25EPF2031L**F104D11-O*	20.31	210	250	2000	3000	600	150.0	125.0
25EPF2539L**F104D11-O*	25.39	210	250	2000	3000	600	156.5	131.5
25EPF3047L**F104D11-O*	30.47	210	250	2000	3000	600	163.0	138.0
25EPF3554L**F104D11-O*	35.54	180	210	2000	3000	600	169.5	144.5
25EPF4062L**F104D11-O*	40.62	180	210	2000	3000	600	176.0	151.0

**Dimensions**

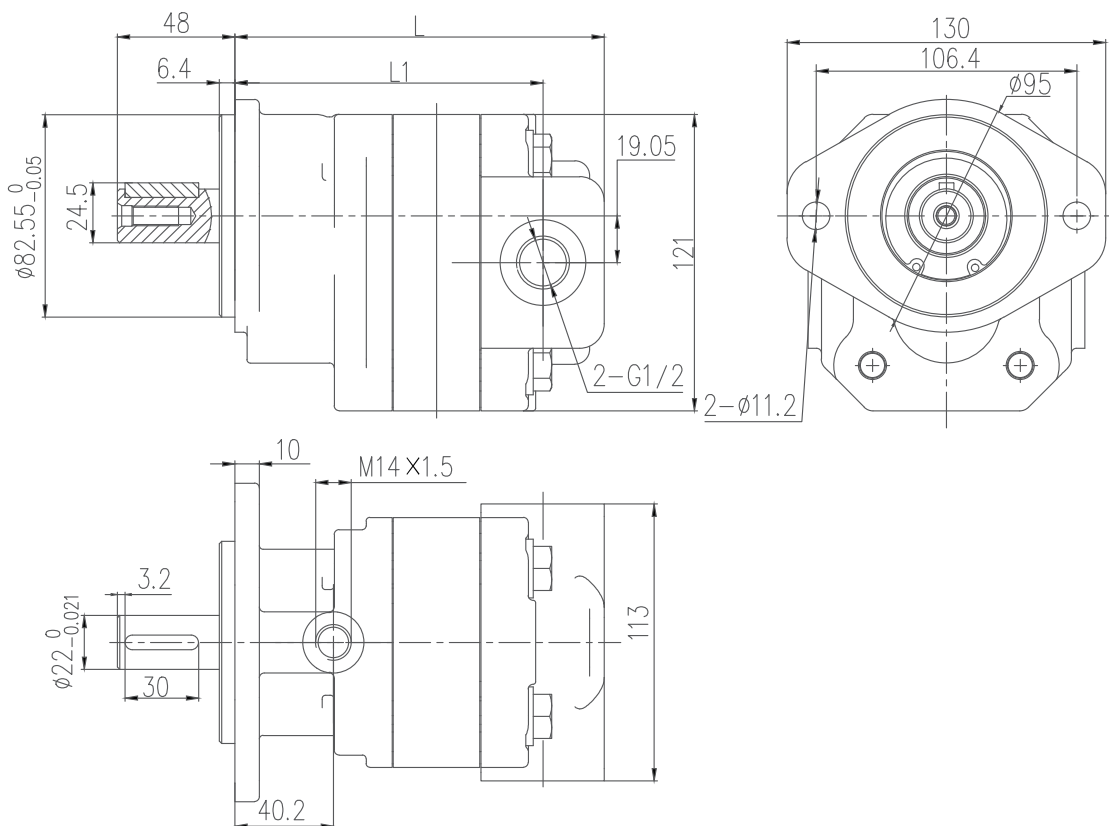

### 3CPF\*\*L\*\*R16S22



Model	Displacement (ml/r)	Pressure(bar)		Speed(r/min)			A (mm)	B (mm)	D (mm)	d (mm)	Weight (kg)
		Rated	Peak	Rated	Max.	Min.					
3CPF43L03R16S22	43	210	300	2000	3000	300	171.0	115.5	G1	G3/4	12.8
3CPF51L00R16S22	51	210	300	2000	3000	300	177.0	118.5	G1	G1	13.2
3CPF61L00R16S22	61	210	300	200	3000	300	183.6	121.8	G1	G1	13.6
3CPF82L11R16S22	82	210	300	200	3000	300	196.0	128.0	G1-1/4	G1	14.1

### Dimensions

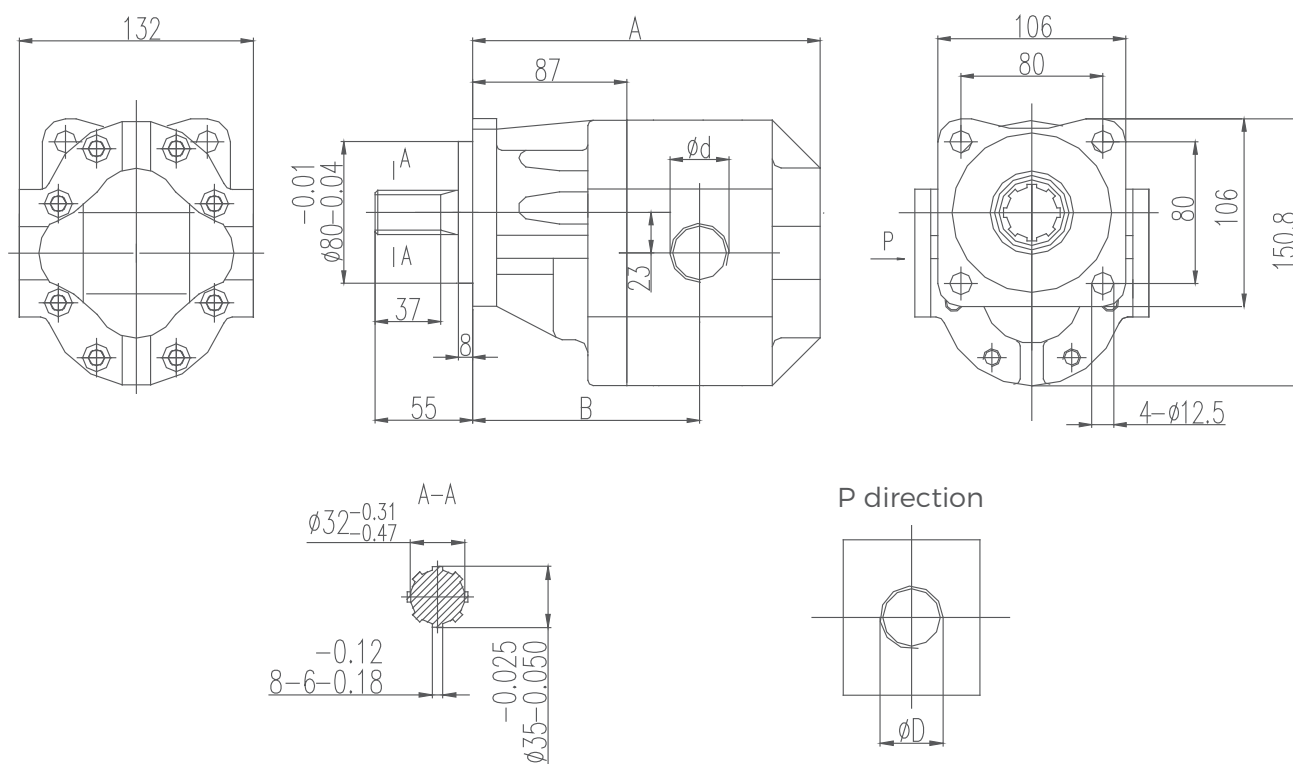

### 3.5EPF\*\*L\*\*R16S22B



Model	Displacement (ml/r)	Pressure(bar)		Speed(r/min)			A (mm)	B (mm)	D (mm)	d (mm)
		Rated	Peak	Rated	Max.	Min.				
3.5EPF82L00R16S22B	82	210	300	2000	3000	300	233	157.5	G1	G1
3.5EPF95L99R16S22B	95	210	300	2000	3000	300	239	160.5	G1-1/4	G1-1/4

### Dimensions

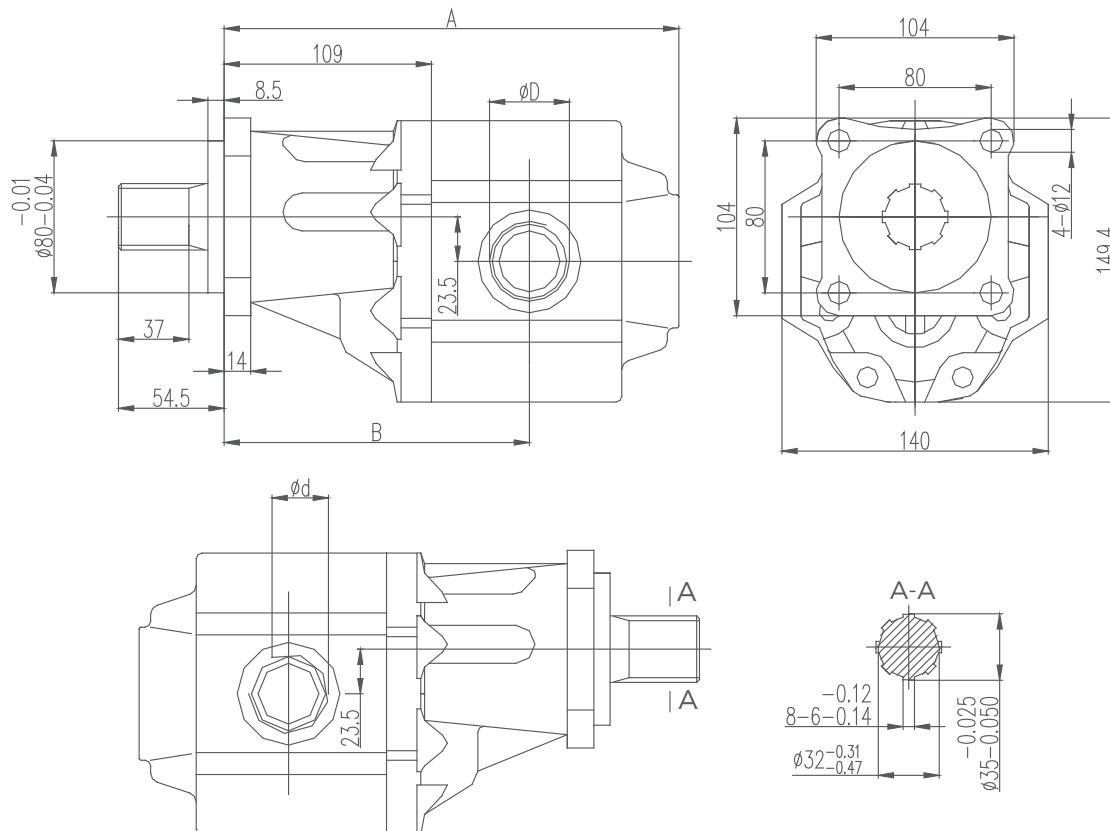

### 3.5APF\*\*F108F102S73SP9-B-O



Model	Displacement (ml/r)	Pressure(bar)		Speed(r/min)			L (mm)	L1 (mm)	T1 (mm)	T2 (mm)
		Rated	Peak	Rated	Max	Min				
3.5APF52F108F102S73SP9-B-O	52	170	210	1500	3600	600	181.0	206.5	1"	1-1/4"
3.5APF63F108F102S73SP9-B-O	63	170	210	1500	3600	600	187.5	216.0	1"	1-1/4"
3.5APF73F108F102S73SP9-B-O	73	170	210	1500	3600	600	193.5	225.3	1-1/4"	1-1/4"
3.5APF85F108F102S73SP9-B-O	85	150	180	1500	3600	600	200.5	235.5	1-1/4"	1-1/4"
3.5APF93F108F102S73SP9-B-O	93	150	180	1500	3600	600	206.5	244.5	1-1/2"	1-1/4"
3.5APF104F108F102S73SP9-B-O	104	150	180	1500	3600	600	213.0	254.5	1-1/2"	1-1/4"
3.5APF115F108F102S73SP9-B-O	115	120	140	1500	3600	600	219.0	263.5	1-1/2"	1-1/4"

### Dimensions

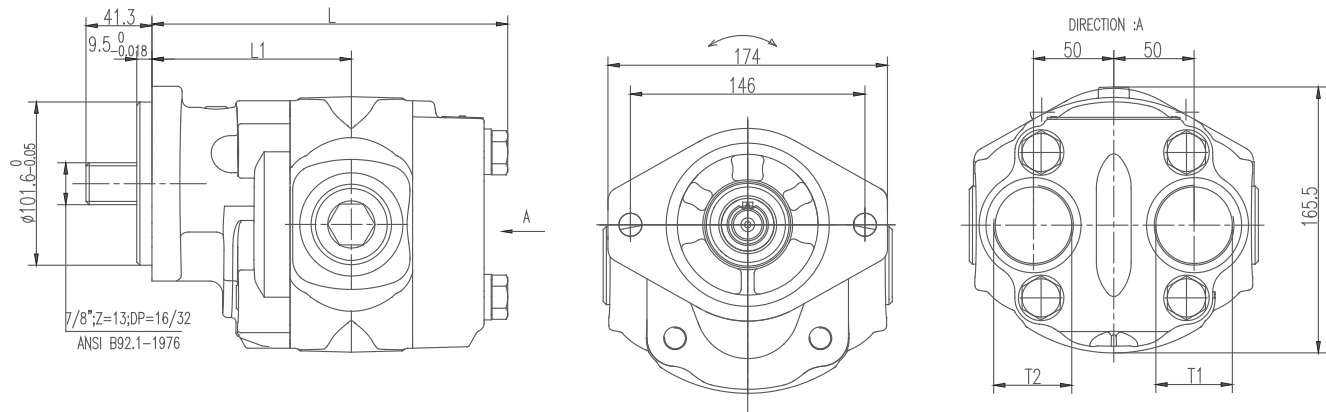

### 3.5APF\*\*L\*\*S84D14\*-B-O



Model	Displacement (ml/r)	Pressure(bar)		Speed(r/min)			L (mm)	L1 (mm)	T1 (mm)	T2 (mm)
		Rated	Peak	Rated	Max	Min				
3.5APF52L**S84D14-B-O	52	170	210	1500	3600	600	181.0	206.5	1"	1-1/4"
3.5APF63L**S84D14-B-O	63	170	210	1500	3600	600	187.5	216.0	1"	1-1/4"
3.5APF73L**S84D14-B-O	73	170	210	1500	3600	600	193.5	225.3	1-1/4"	1-1/4"
3.5APF85L**S84D14-B-O	85	150	180	1500	3600	600	200.5	235.5	1-1/4"	1-1/4"
3.5APF93L**S84D14-B-O	93	150	180	1500	3600	600	206.5	244.5	1-1/2"	1-1/4"
3.5APF104L**S84D14-B-O	104	150	180	1500	3600	600	213.0	254.5	1-1/2"	1-1/4"
3.5APF115L**S84D14-B-O	115	120	140	1500	3600	600	219.0	263.5	1-1/2"	1-1/4"

### Dimensions

#### 3.5APF\*\*L\*\*S84D14-B-O

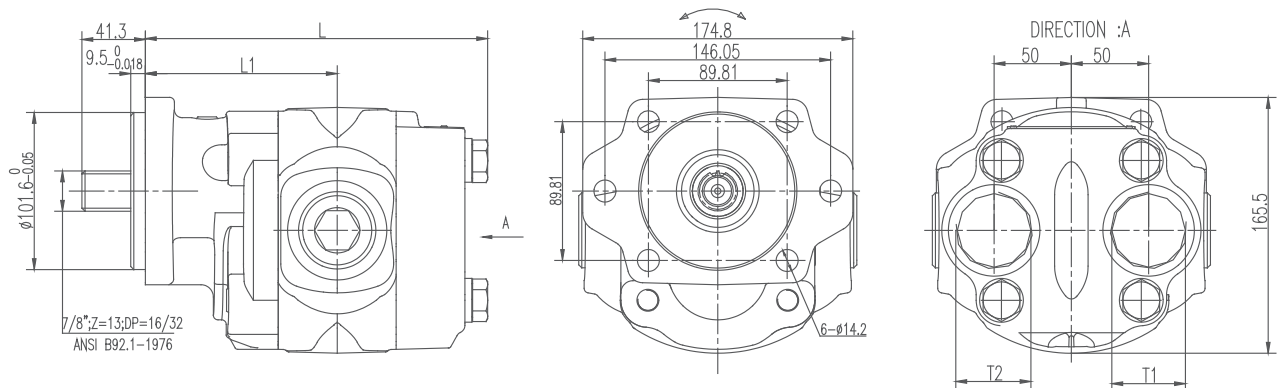

#### 3.5BPF\*\*F108F102S73SP9-B-O

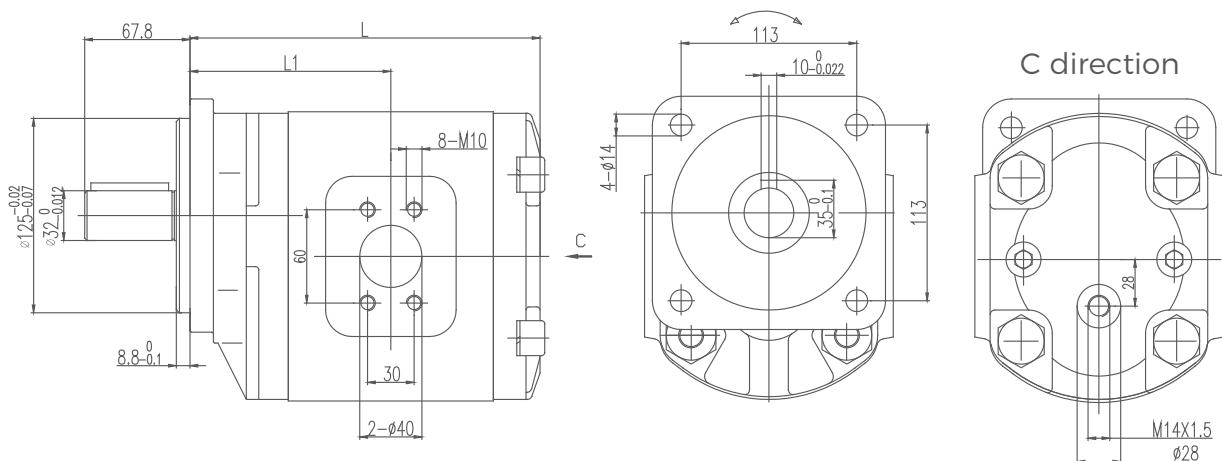



## 4PF\*\*F\*\*S83S20L



Model	Displacement (ml/r)	Pressure(bar)		Speed(r/min)			L(mm)	L1(mm)
		Rated	Peak	Rated	Max.	Min.		
4PF66F161S83S20L	66	210	250	1800	2200	600	197.3	121.0
4PF83F161S83S20L	83	210	250	1800	2200	600	203.5	124.1
4PF91F161S83S20L	91	210	250	1800	2200	600	207.3	126.0
4PF99F161S83S20L	99	210	250	1800	2200	600	209.8	127.2
4PF116F161S83S20L	116	210	250	1800	2200	600	217.3	130.9
4PF132F161S83S20L	132	210	250	1800	2200	600	222.6	133.5
4PF145F161S83S20L	145	210	250	1800	2200	600	227.8	136.1
4PF149F161S83S20L	149	210	250	1800	2200	600	229.3	136.8
4PF166F161S83S20L	166	210	250	1800	2200	600	235.3	139.8
4PF182F161S83S20L	182	180	210	1800	2200	600	241.3	142.8
4PF199F161S83S20L	199	180	210	1800	2200	600	248.3	146.3

## Dimensions

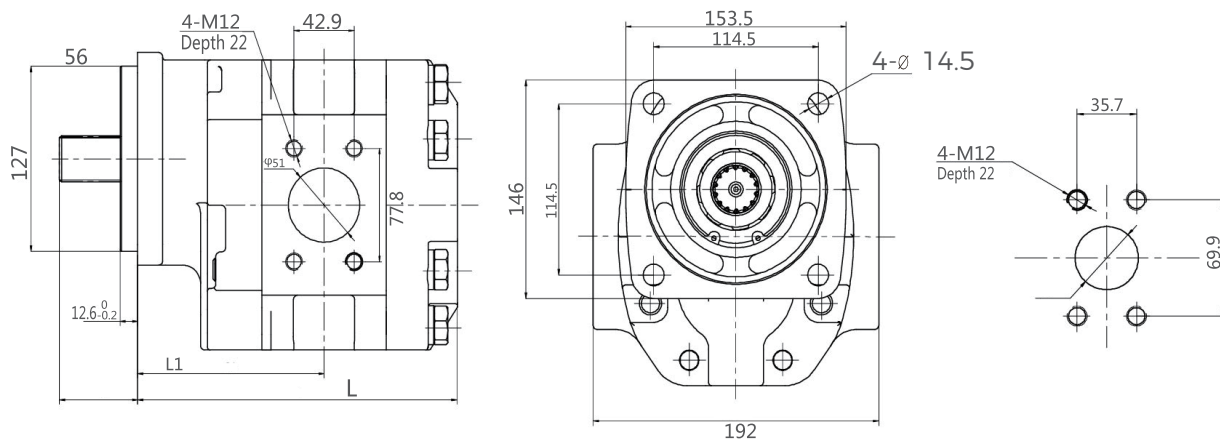

## XTYBA Gear Pumps

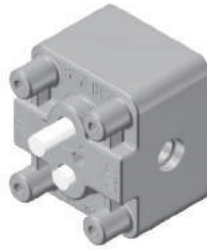

Model	Displacement (ml/r)	Pressure(bar)		Speed(r/min)	
		Rated	Peak	Rated	Max.
XTYBA	10	20	30-50	1500	2500

## Dimensions

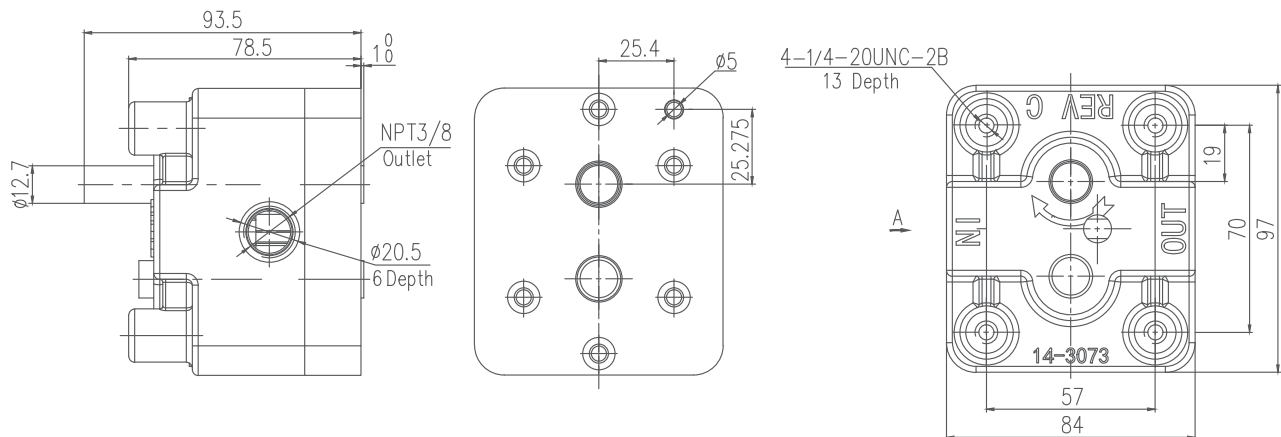

## C101 C102 G101 G102 Series Dump Pumps

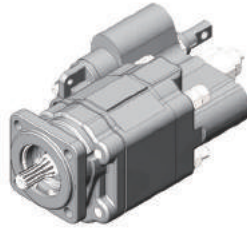

Model	Teeth Width(in.)	Displacement (ml/r)	Pressure(bar)		Speed(r/min)		Input Power (Kw)	Features
			Rated	Peak	Peak	Min.		
C101-20-MS/AS-R	2	85	175	210	2400	600	78	Double Shaft
C101-25-MS/AS-R	2-1/2	105	175	210	2400	600	89	Double Shaft
C102-20-MS/AS-L	2	85	175	210	2400	600	78	Single Shaft
C102-25-MS/AS-L	2-1/2	105	175	210	2400	600	89	Single Shaft
G101-07-MS/AS-R	3/4	25	175	210	2400	600	27	Double Shaft
G101-20-MS/AS-R	2	65	175	210	2400	600	70	Double Shaft
G102-15-MS/AS-L	1-1/2	50	175	210	2400	600	89	Single Shaft
G102-20-MS/AS-L	2	65	175	210	2400	600	70	Single Shaft

## Dimensions

### C101 C102 Dump Pump

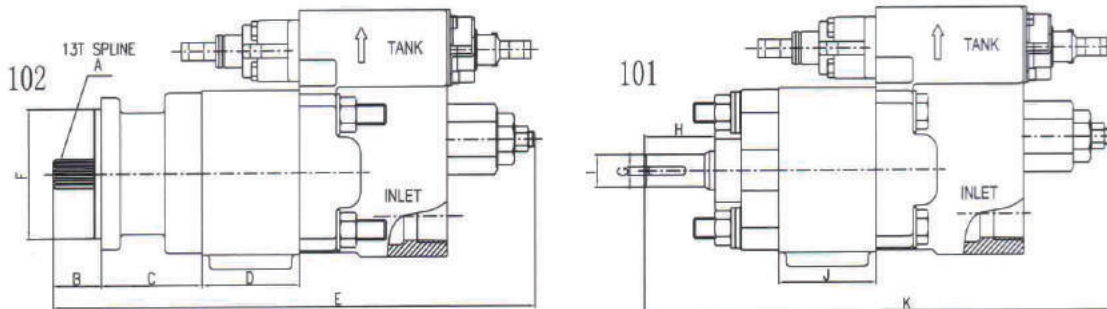

	A	B	C	D			E	D
G102	SAE B	1.62	2.94	1.50(07)	2.25(15)	2.75(20)	11.25+D	4
C102	SAE B	1.62	3.37	2.75(20)	3.25(25)		13.25+D	4

  

	G	H	I	J			K
G101	0.25	1.94	1.00	1.50(07)	2.25(15)	2.75(20)	10.43+J
C101	0.25	2.38	1.00	2.75(20)	3.25(25)		12.75+J

## Installation and Operation

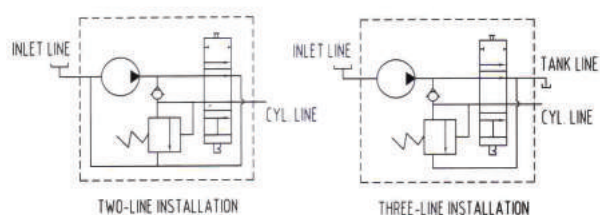

## Air Shifters

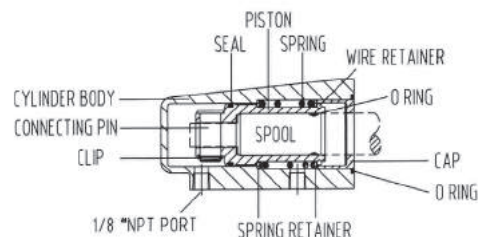

### HGP19L10F103SP14



Model	Displacement (ml/r)	Pressure(bar)		Speed(r/min)	
		Rated	Peak	Rated	Max.
HGP19L10F103SP14	10	50	70	200	1200

### Dimensions

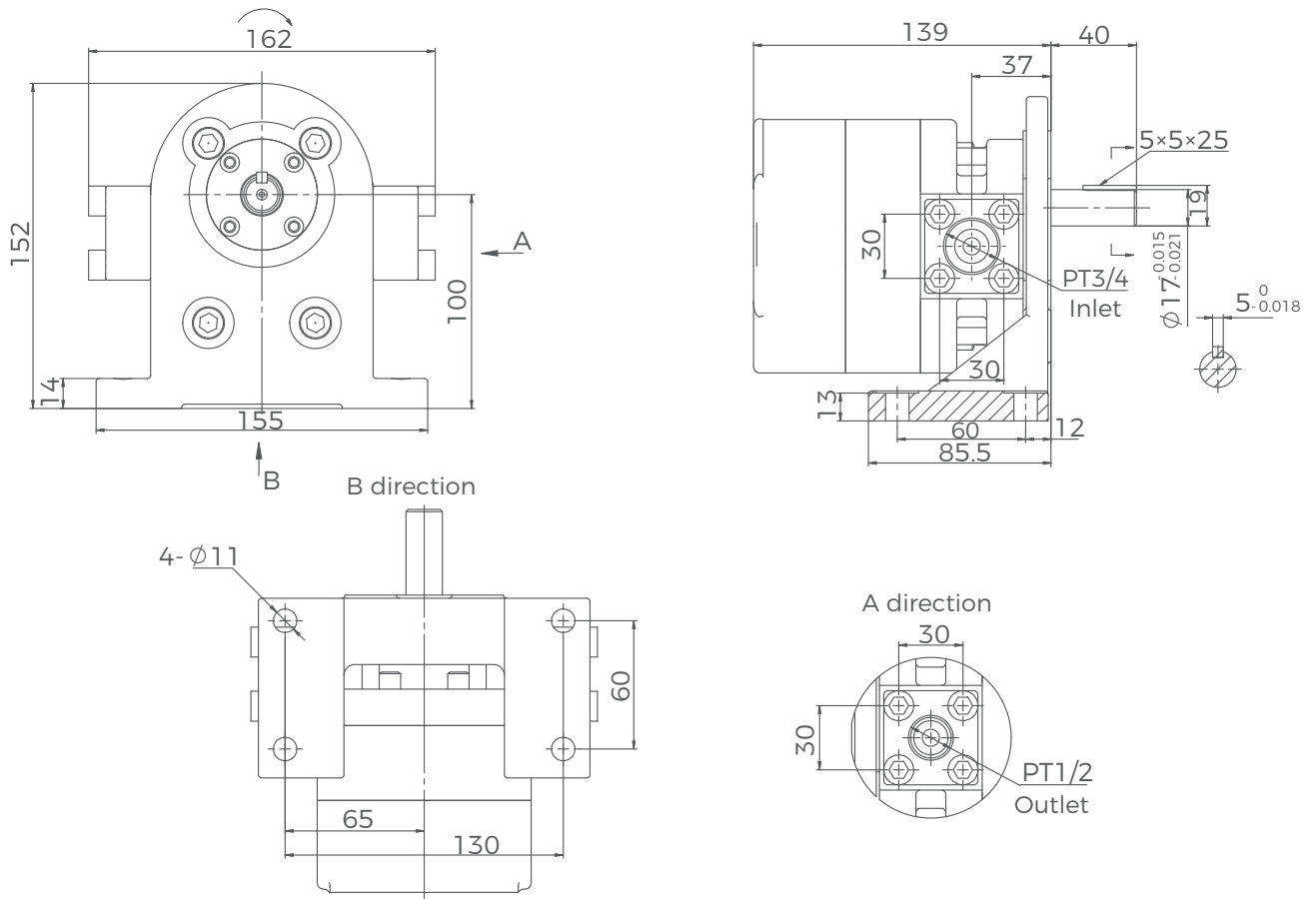

## Cat Pumps

These pumps can be used in the hydraulic systems of bulldozer, loader, crane and other construction machineries.

Model	Displacement (ml/r)	Pressure(bar)		Speed(r/min)			Min.flow at rated pressure and speed (L/min)	Rotation	Weight (Kg)
		Rated	Peak	Rated	Peak	Min.			
4W5479	8.0	0.25	0.35	1500	2000	500	10.8	CCW	18.4
5H1719	12.0	0.80	2.00	1500	2000	500	15.0	CCW	15.0
3N2078	16.0	2.00	3.00	1500	2000	500	19.0	CCW	19.4
3S4386	22.0	2.50	3.15	1500	2000	500	30.0	CW	19.4
5M7864	28.0	2.50	3.15	2000	2500	500	45.6	CCW	18.4
3P6814	32.0	2.50	3.15	1800	2500	500	45.0	CW	18.4
7S4629	40.0	2.50	3.15	2000	2500	500	18.0	CCW	18.4
7G4856	47.0	26.00	35.00	1500	2000	500	78.0	CCW	23.2
1192924	47.5	26.00	35.00	1500	2500	500	66.0	CW	5.0
9P9610	55.0	26.00	35.00	1500	2000	500	91.5	CCW	24.5
1233472	55.0	26.00	35.00	1500	2000	500	91.5	CCW	22.3
1226658	55.0	26.00	35.00	1500	2500	500	91.5	CCW	25.2
9U9535	65.0	26.00	35.00	1500	2000	500	108.0	CCW	26.5
3P4002	71.0	3.00	4.00	2000	2500	500	174.0	CW	15.5
3P6816/3P0380	71.0	2.50	3.15	1800	2500	500	115.0	CW	19.4
8E1217	73.0	26.00	35.00	1500	2000	500	121.5	CCW	31.5
2P9239	73.3	2.50	3.15	1800	2500	500	122.0	CW	15.5
3G4768	90.0	16.00	20.00	2000	2500	500	180.0	CCW	19.4
4W2448	Front: 62.0	2.00	3.00	1500	2000	500	109.0	CW	25.0
	Rear: 48.0	2.00	3.00				82.0		

## 4W5479/5H1719 Cat Pumps

### 4W5479 Dimensions

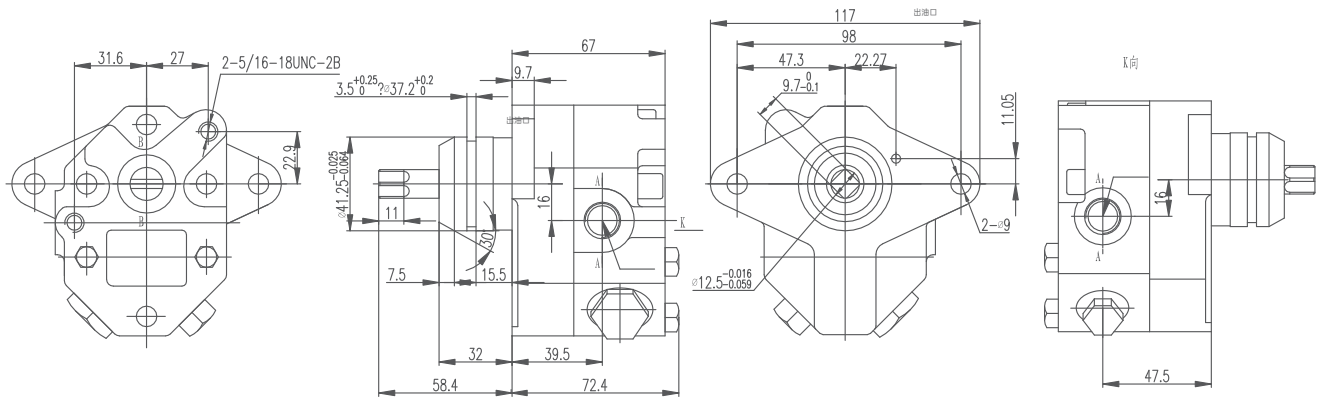
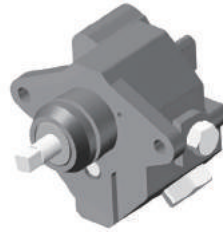

### 5H1719 Dimensions

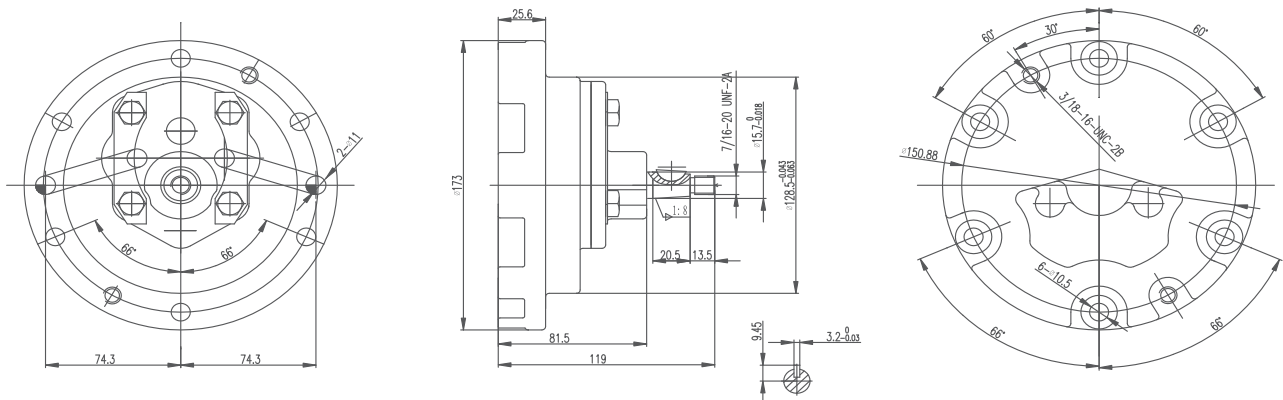

### 3N2078/3S4386 Cat Pumps

#### 3N2078 Dimensions

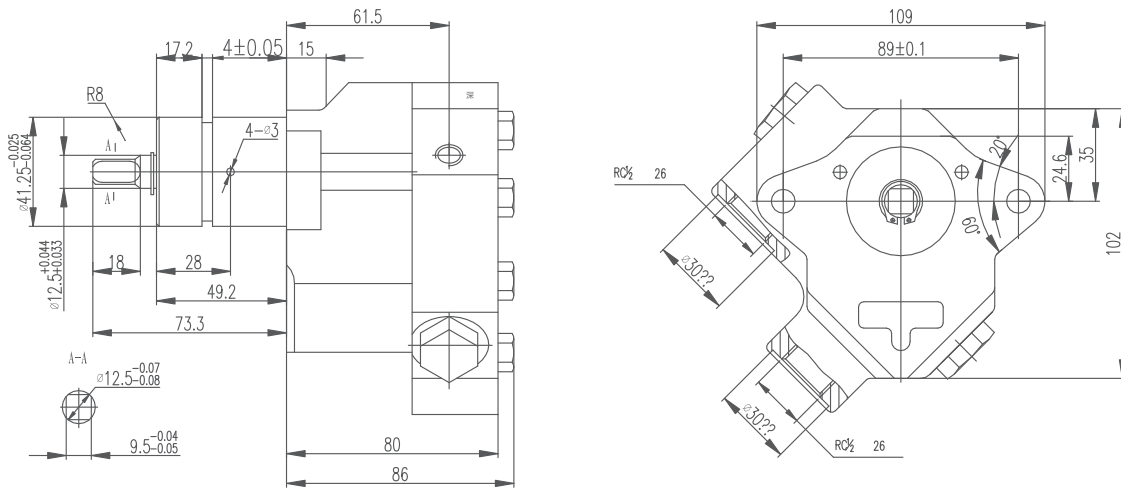

#### 3S4386 Dimensions

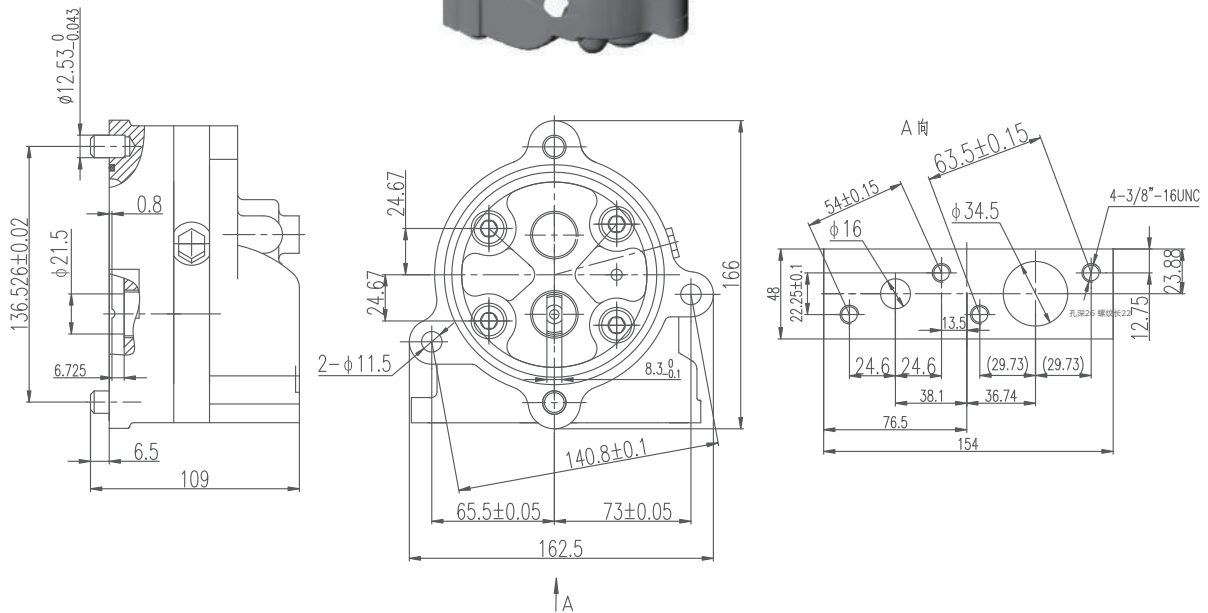

### 5M7864/3P6814/3P6816 Cat Pumps

#### 5M7864 Dimensions

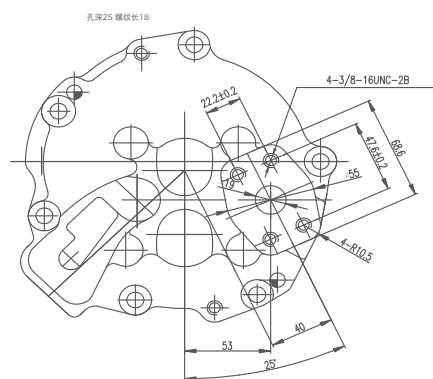
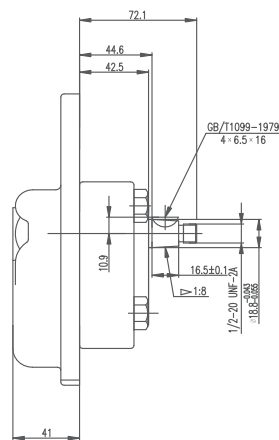
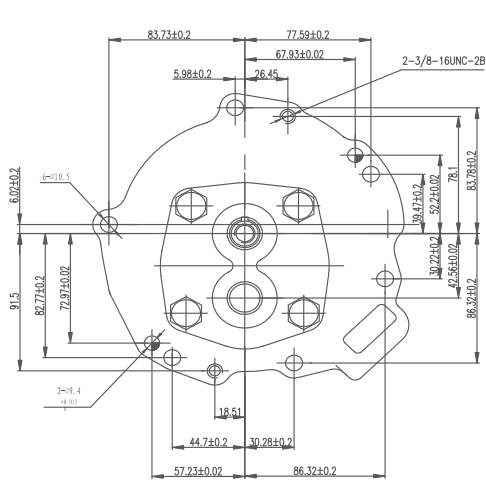

#### 3P6814 / 3P6816 Dimensions

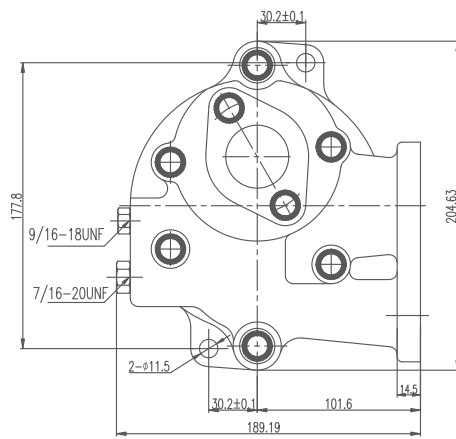
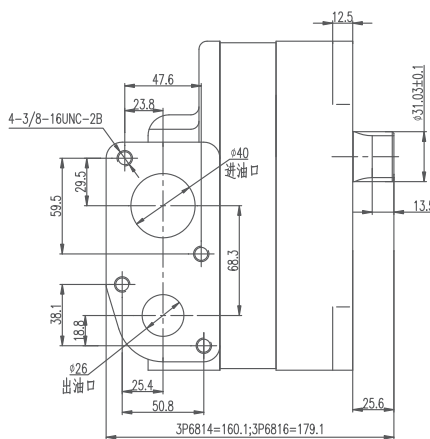
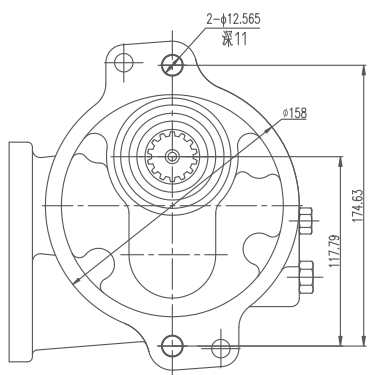



### 7S4629/7G4856 Cat Pumps

#### 7S4629 Dimensions

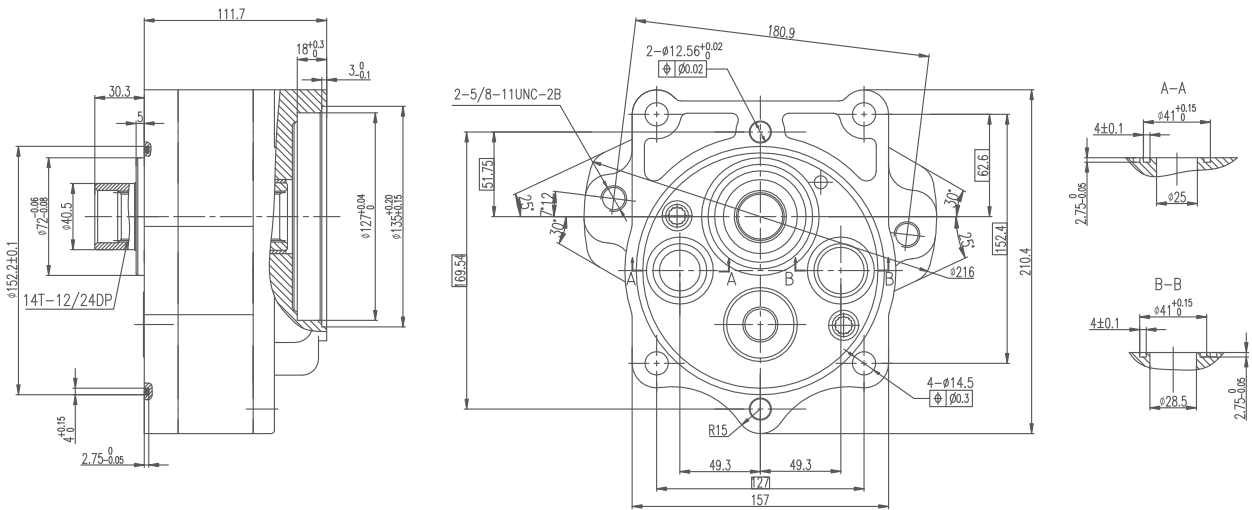

#### 7G4856 Dimensions

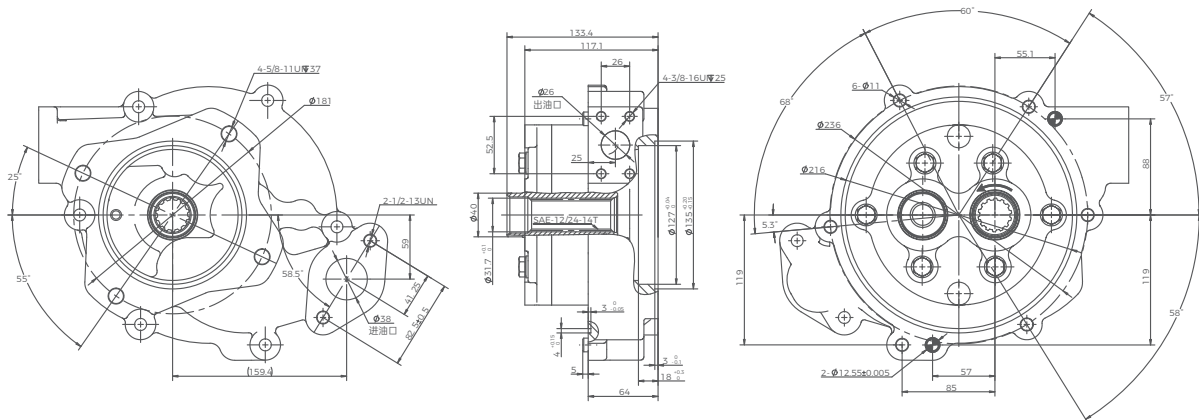

### 1192924/9P9610 Cat Pumps

#### 1192924 Dimensions

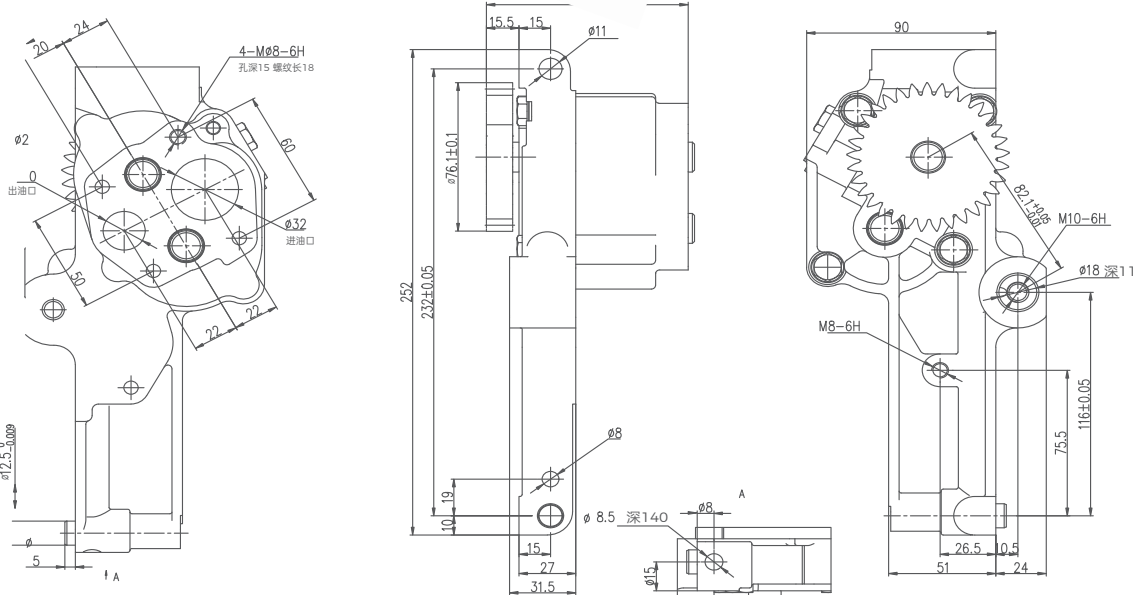
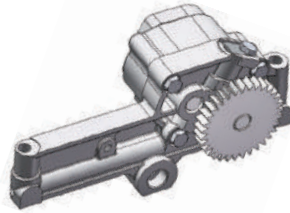

#### 9P9610 Dimensions

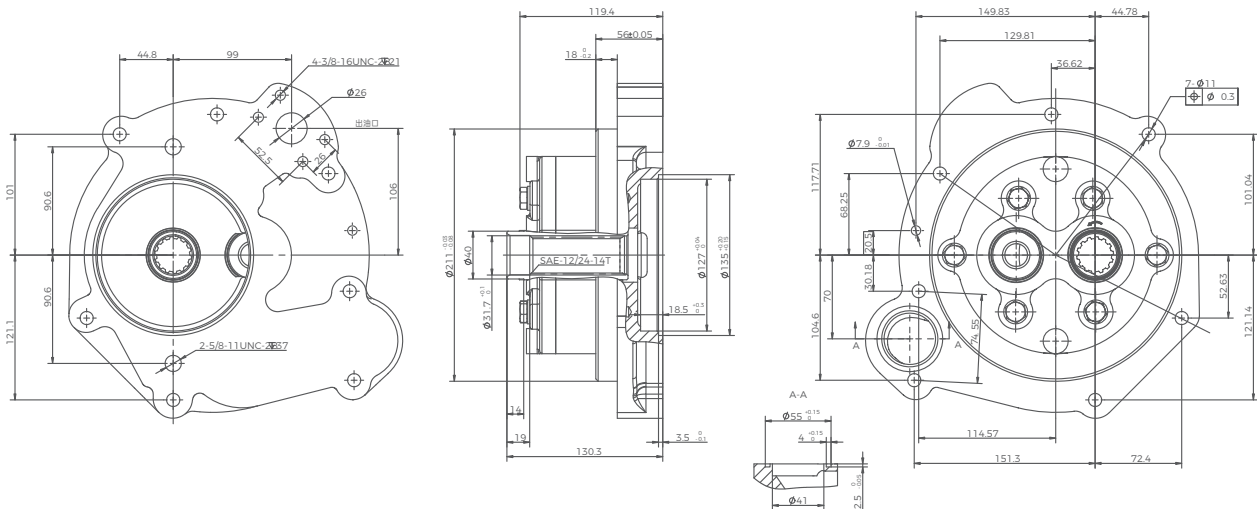

### 1233472/1226658 Cat Pumps

#### 1233472 Dimensions

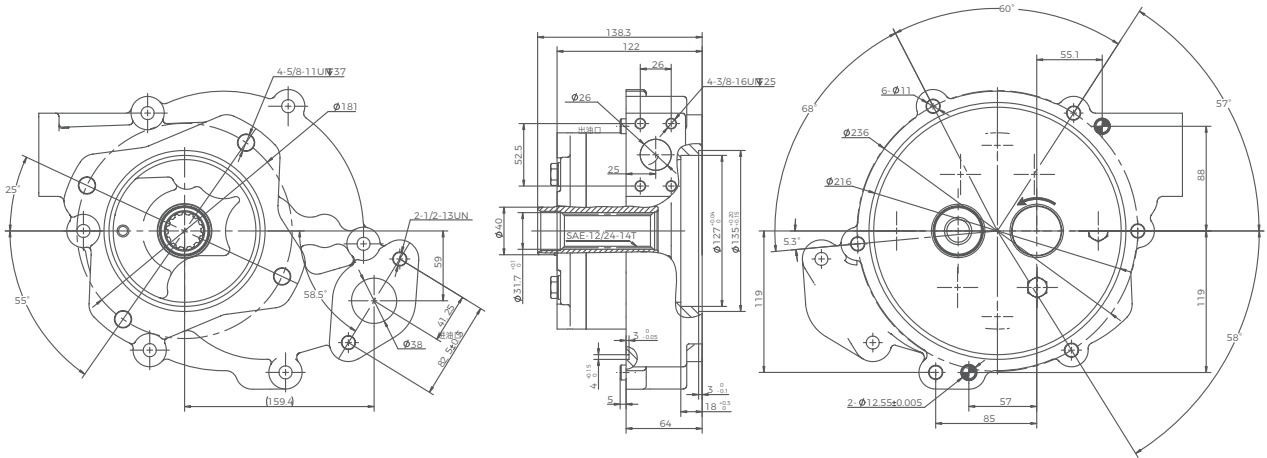

#### 1226658 Dimensions

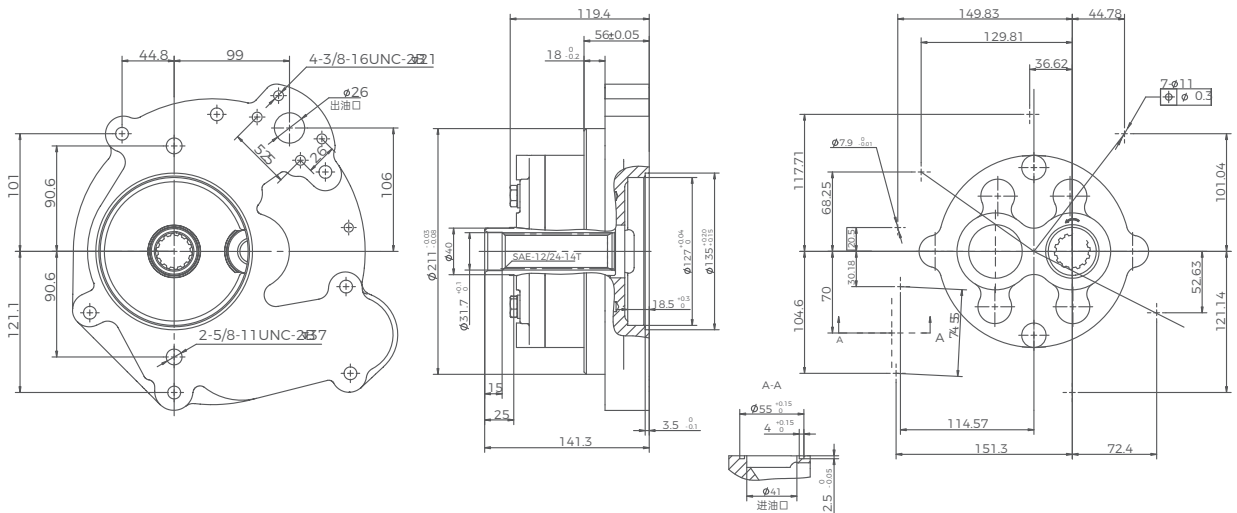

### 9U9535/3P4002 Cat Pumps

### 9U9535 Dimensions

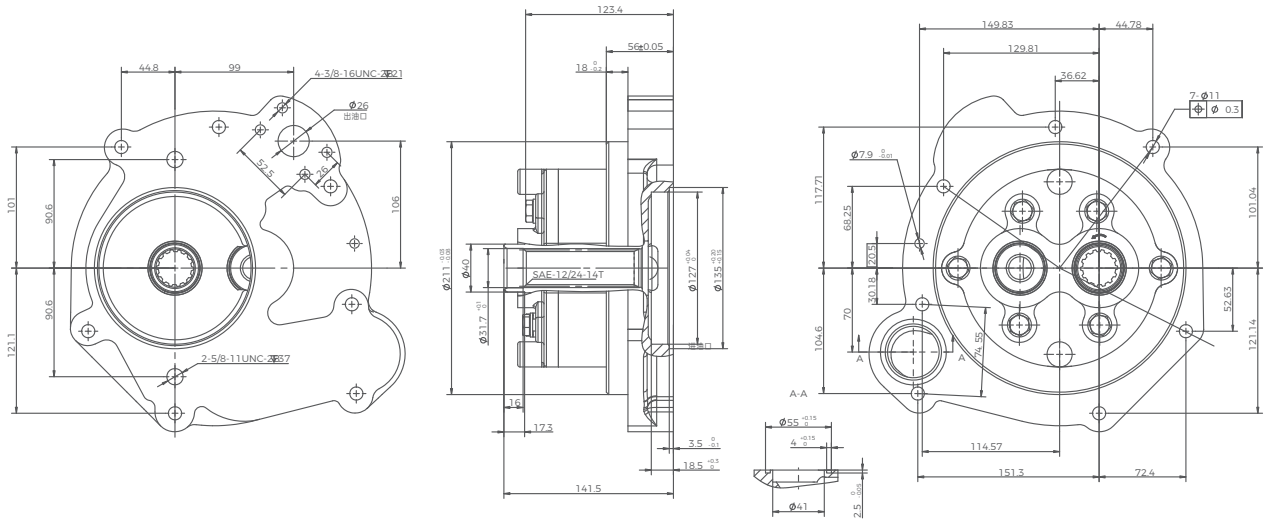

### 3P4002 Dimensions

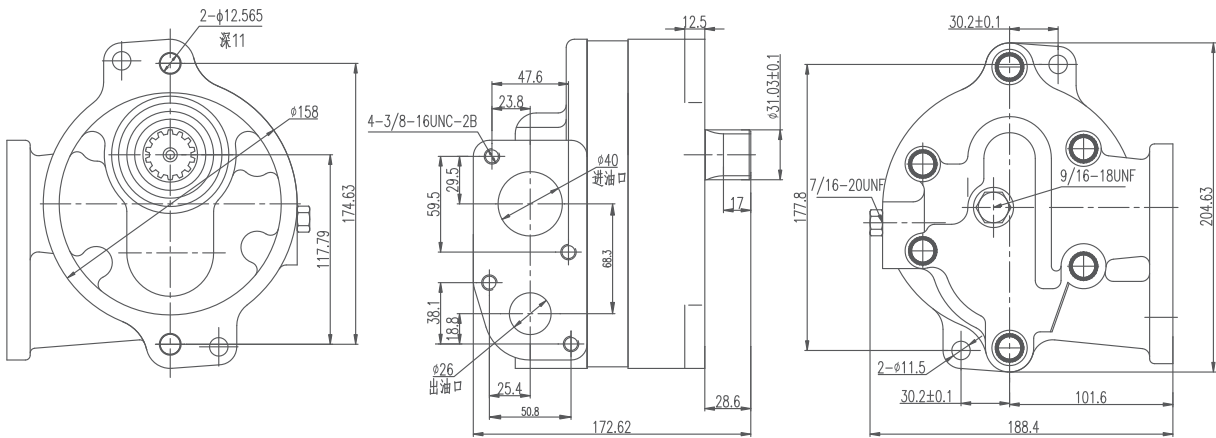

### 3P0380/8E1217 Cat Pumps

#### 3P0380 Dimensions

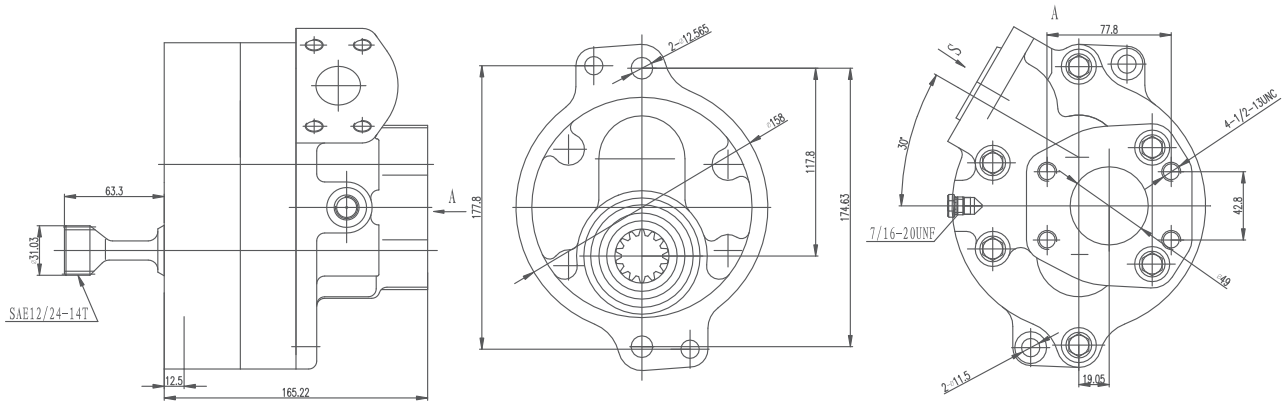

#### 8E1217 Dimensions

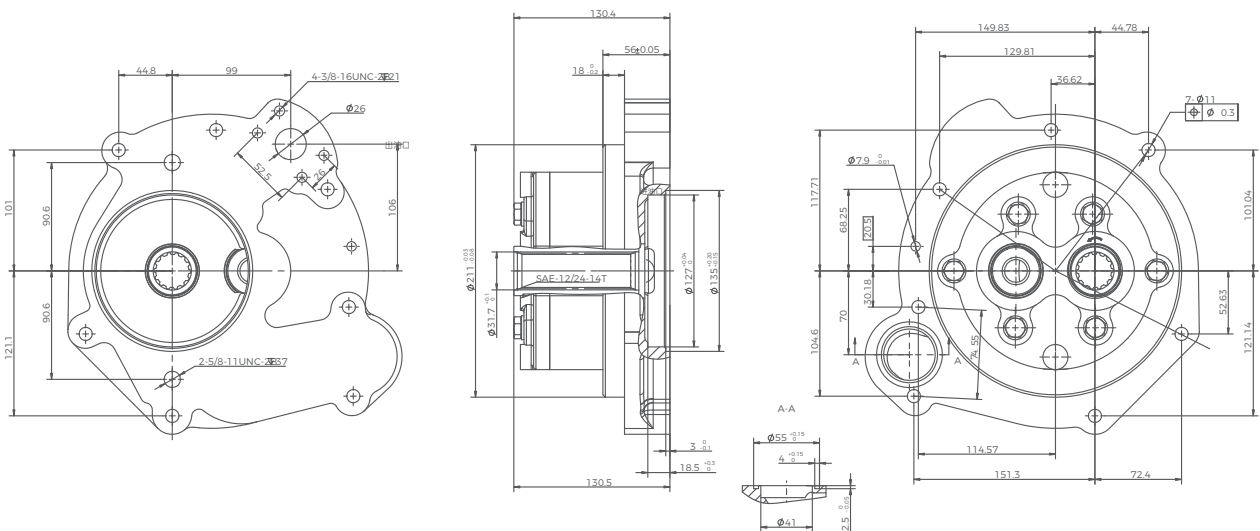

## 2P9239/3G4768 Cat Pumps

### 2P9239 Dimensions

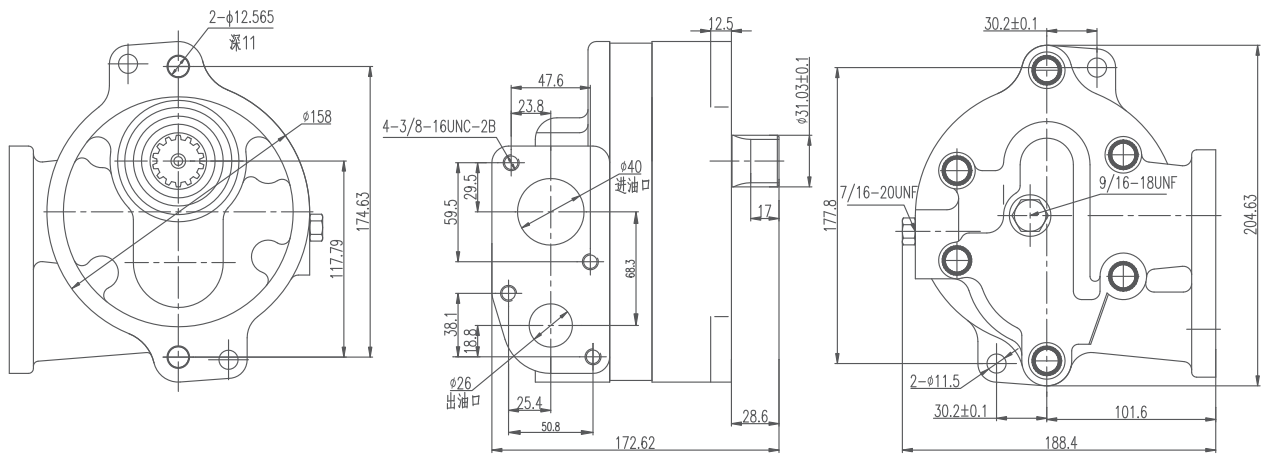

### 3G4768 Dimensions

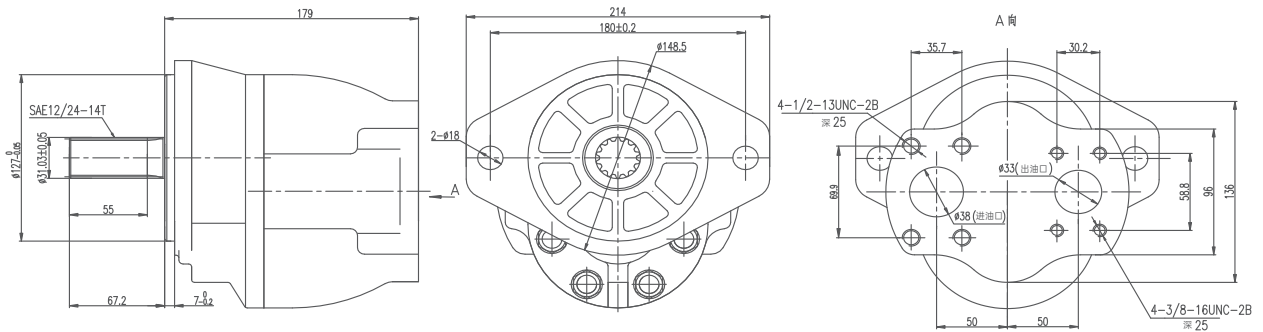

## 4W2448 Cat Pumps

### 4W2448 Dimensions

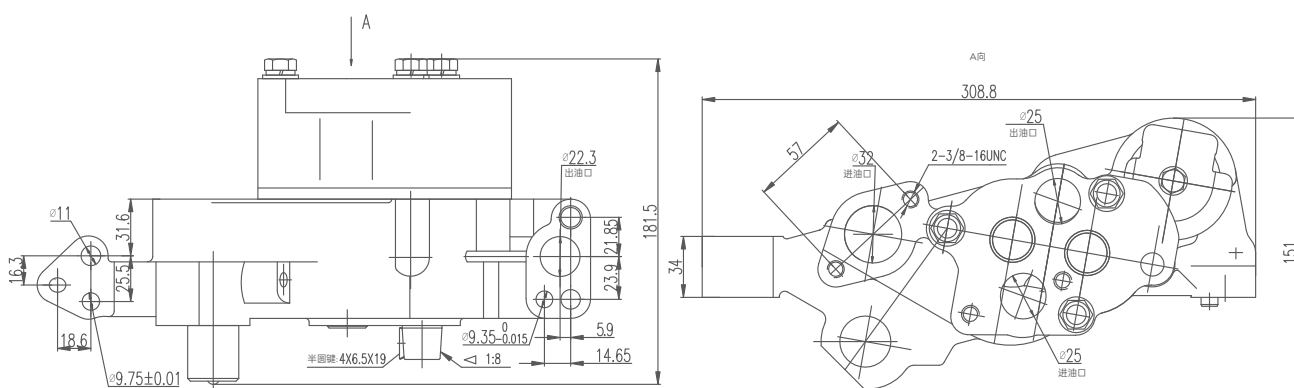

### Inlet/outlet combination

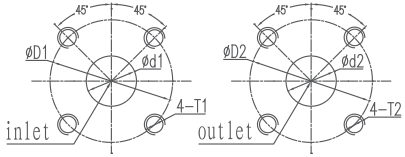
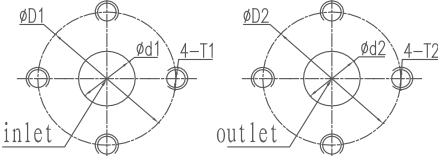
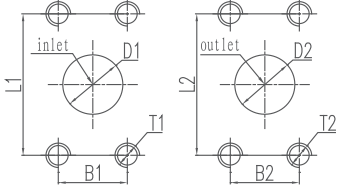
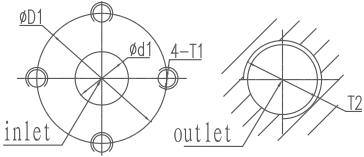
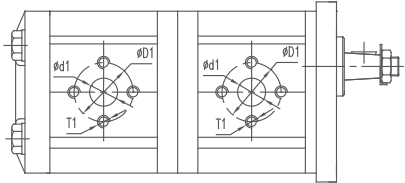
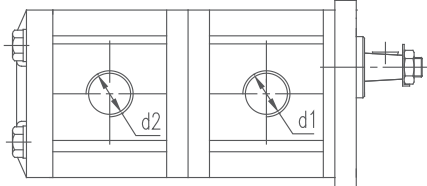
Inlet/Outlet	Ports Type
	Inlet/outlet thread combination
	X Shape Inlet/outlet flange combination
	+ Shape Inlet/outlet flange combination
	# Shape Inlet/outlet flange combination
	Inlet/outlet thread and flange combination
	Double pump inlet/outlet flange combination
	Double pump inlet/outlet thread combination



**Oblate Type Shafts**

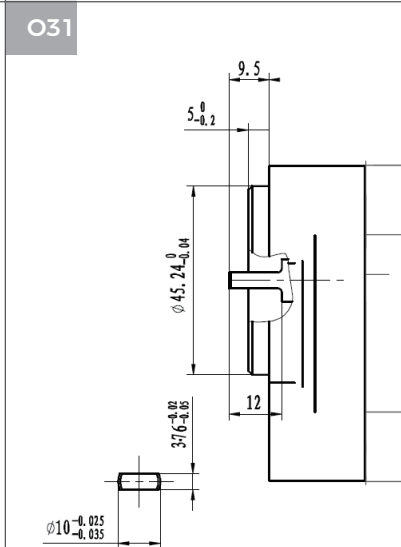
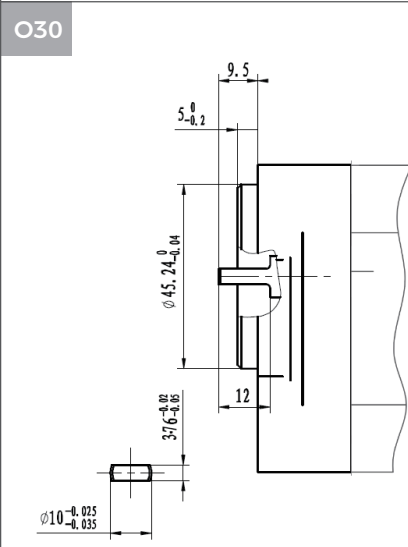
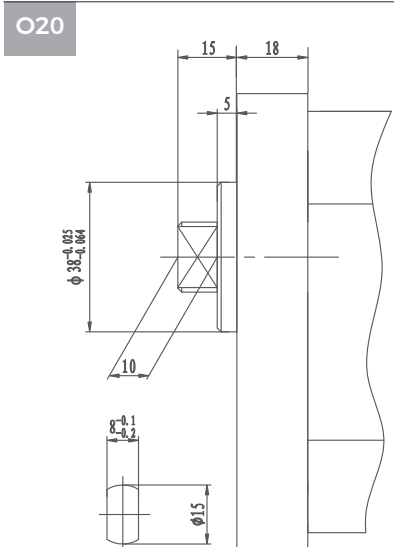
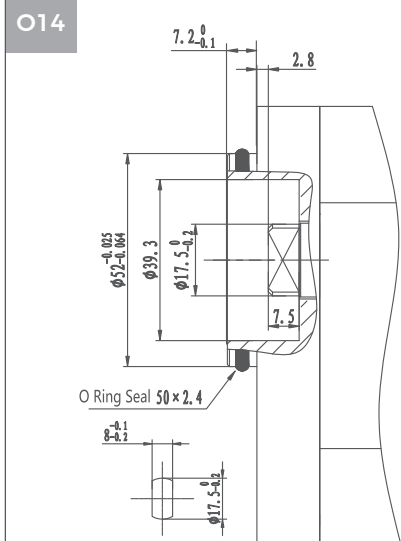
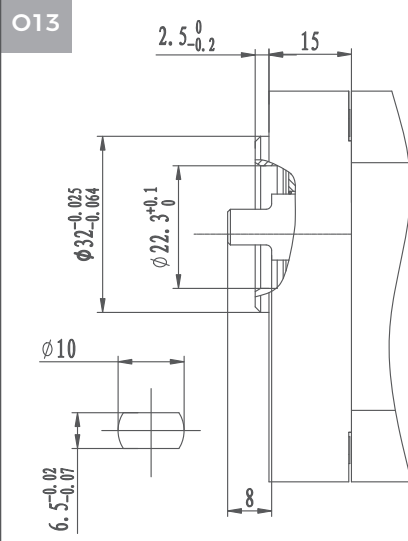
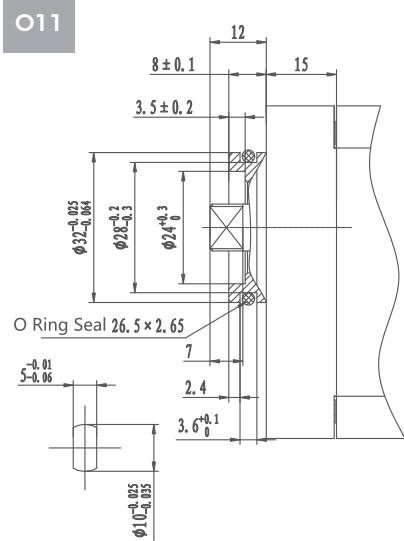
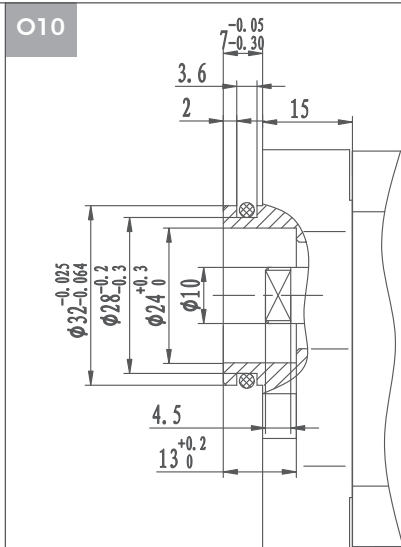
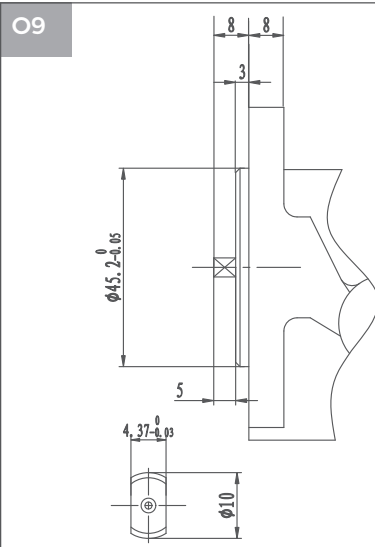
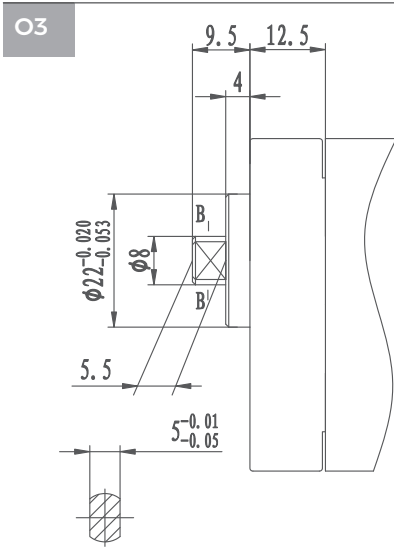

### Flat Keyed Type Shafts

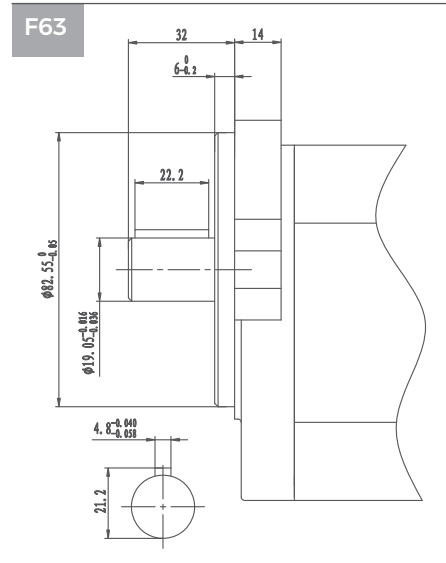
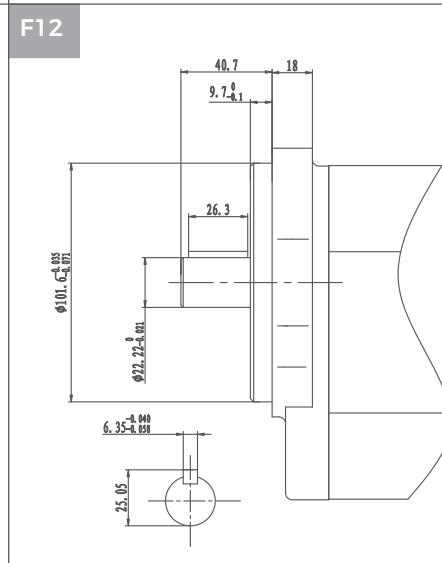
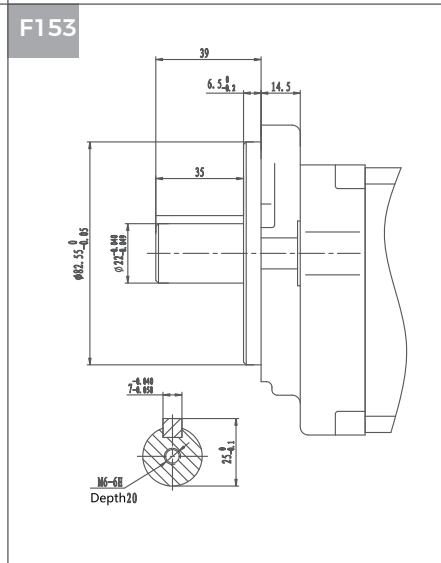
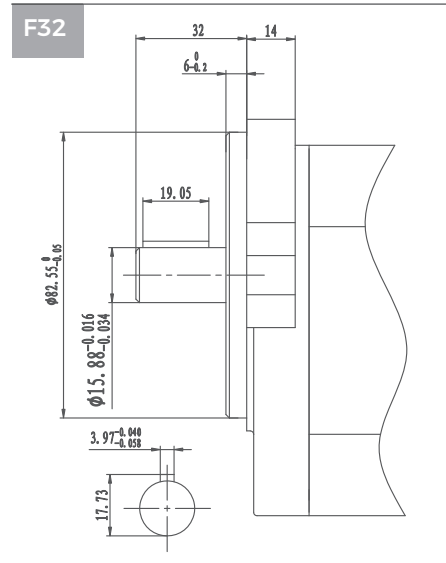
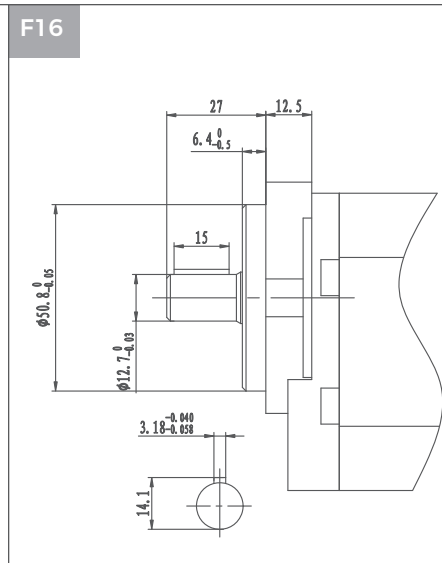
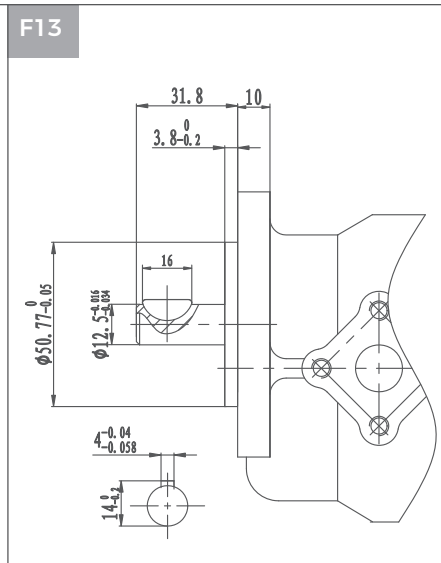
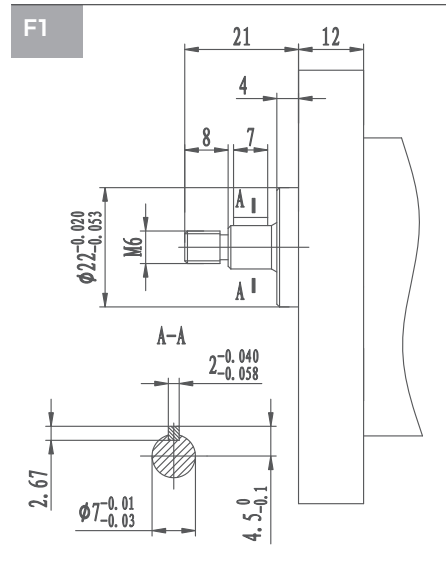

### Taper Key Type Shafts

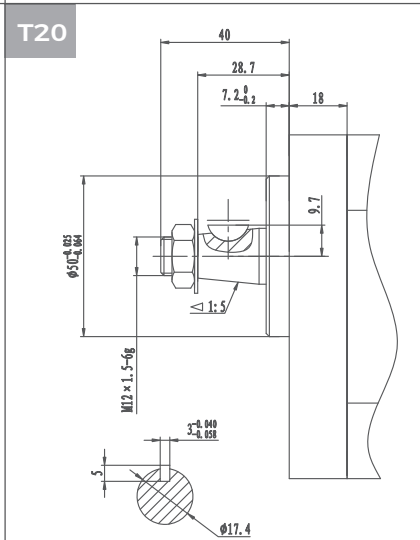
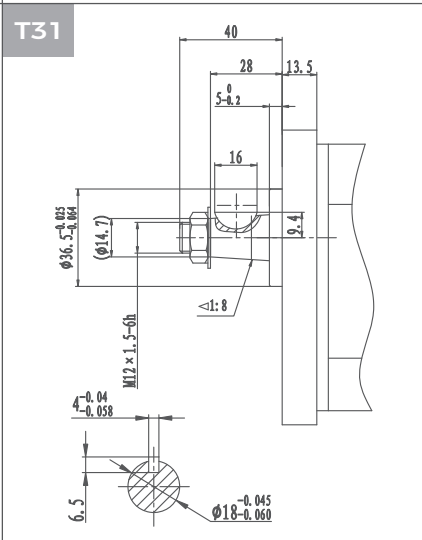
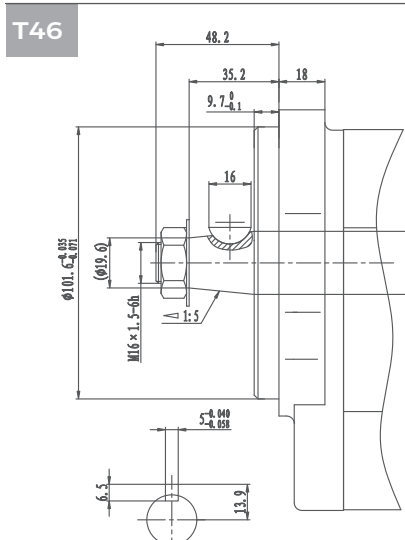
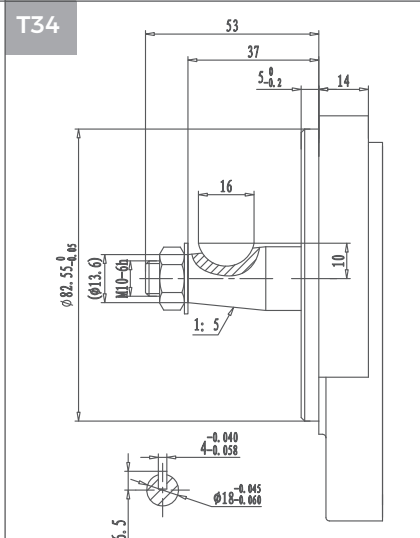
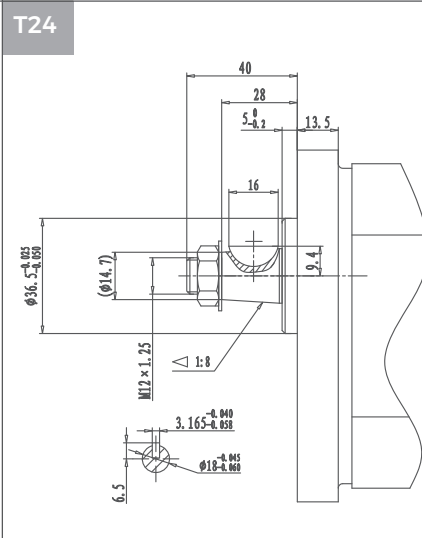
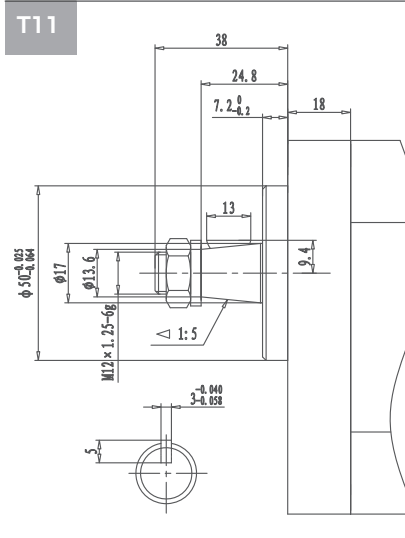
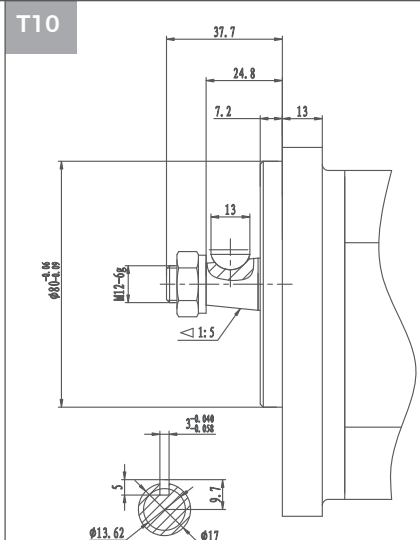
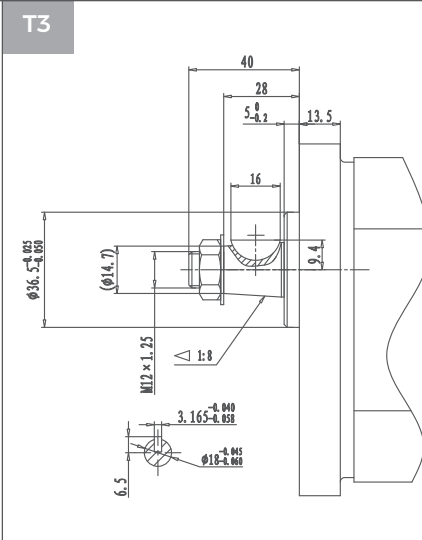
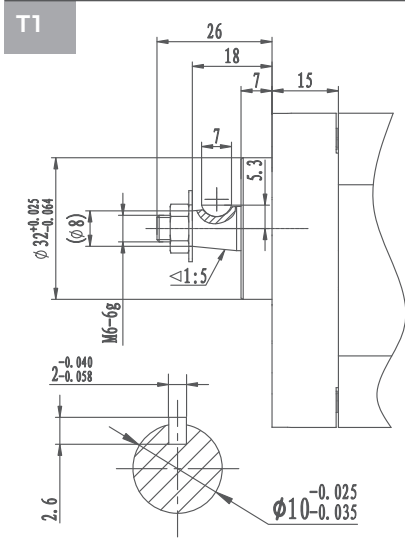

### SAE and Metric Involute Spline Type Shafts

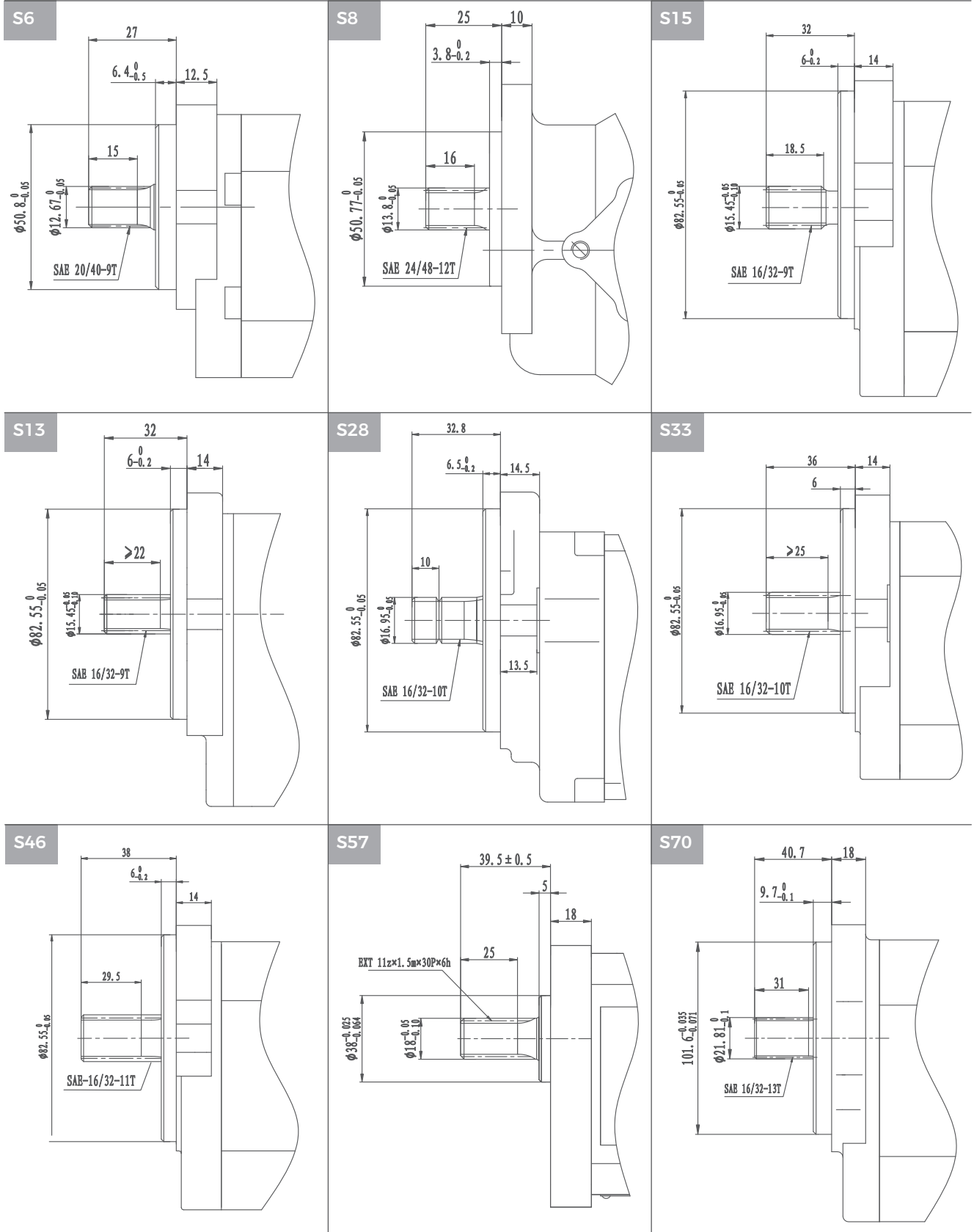

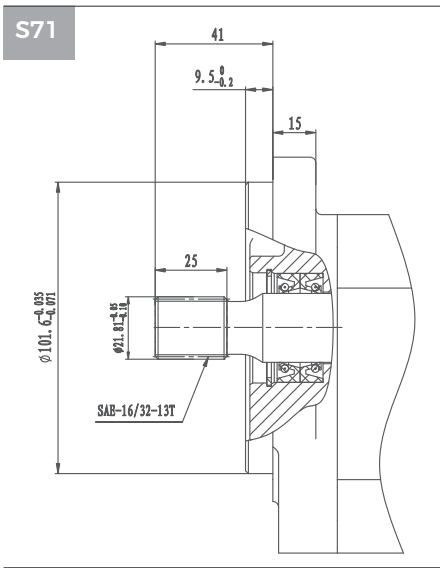

**DIN Spline Type Shafts**

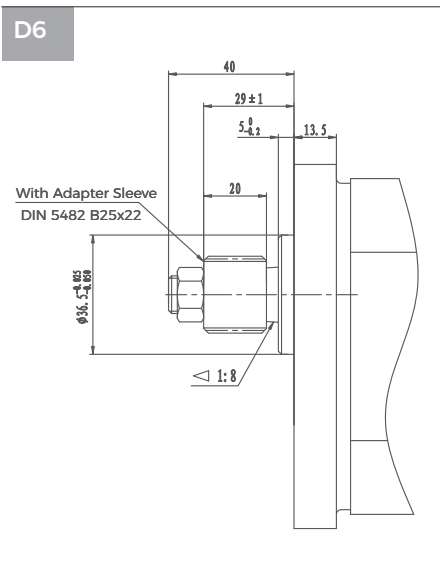
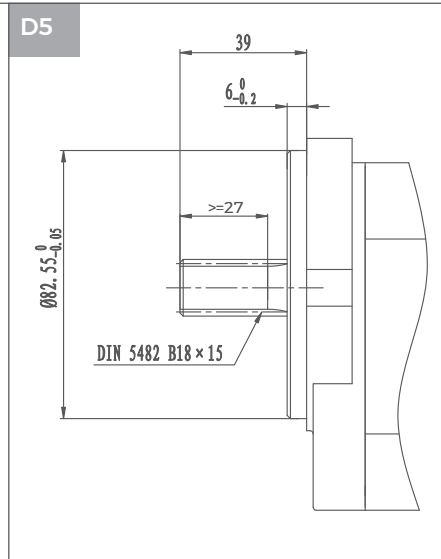
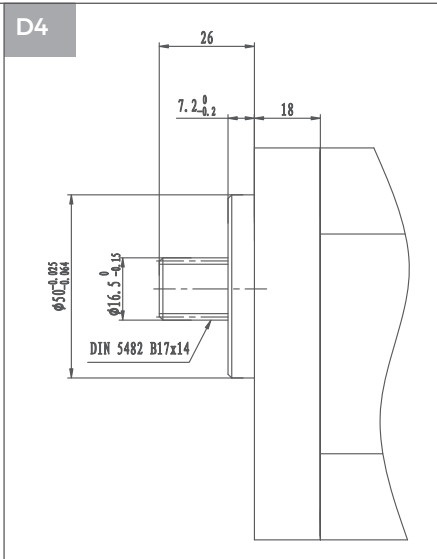
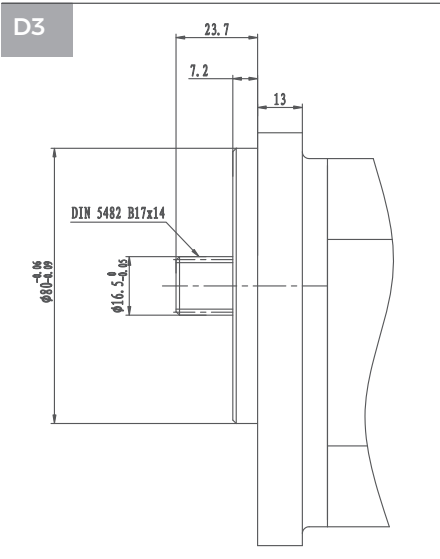

### Diamond Type Front Covers

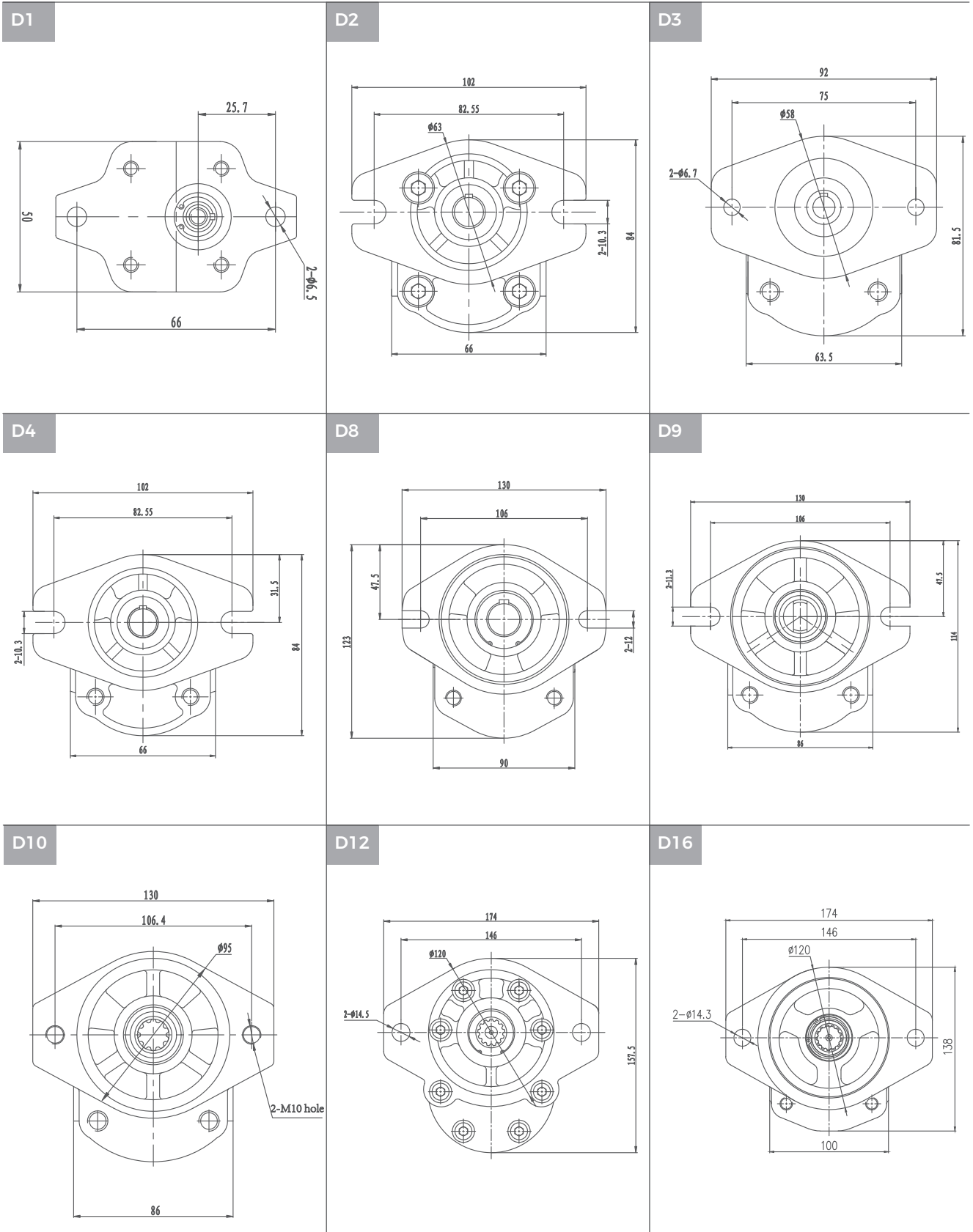

Oval Type Front Covers

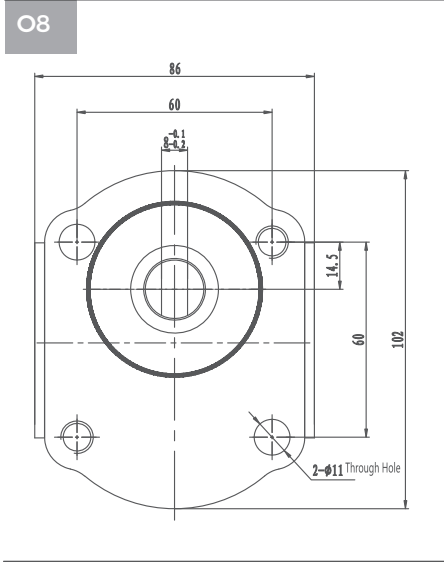
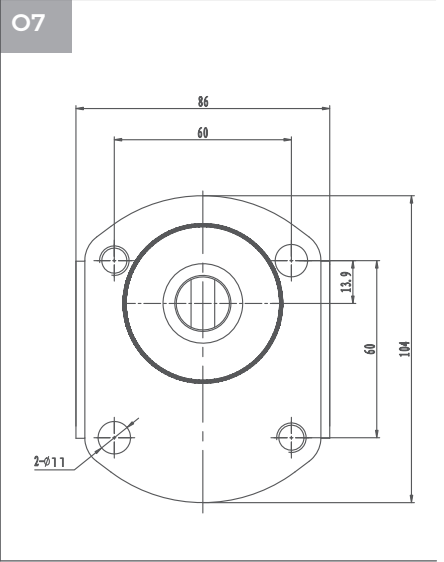
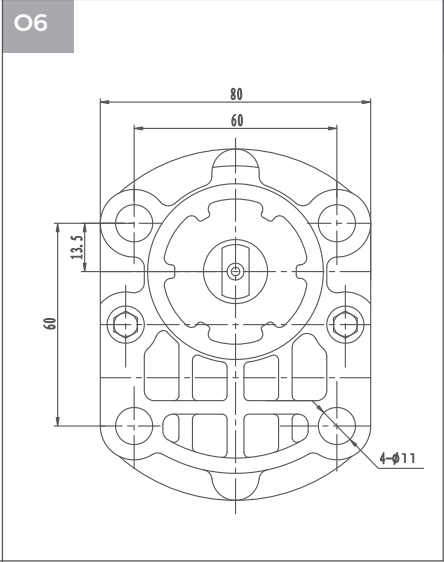
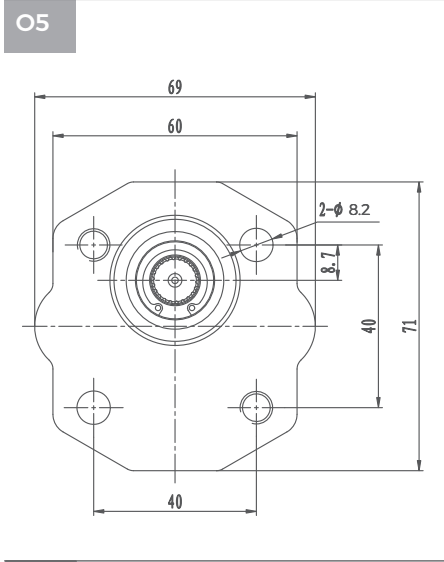
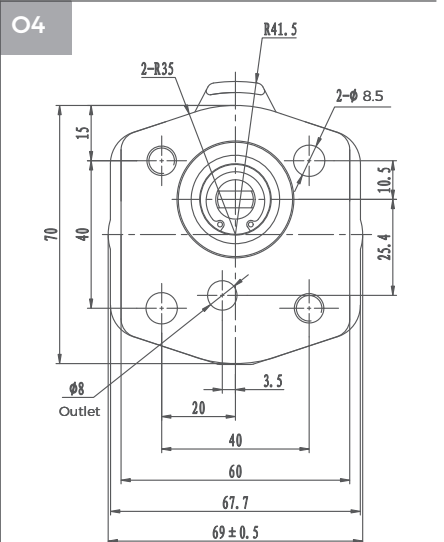
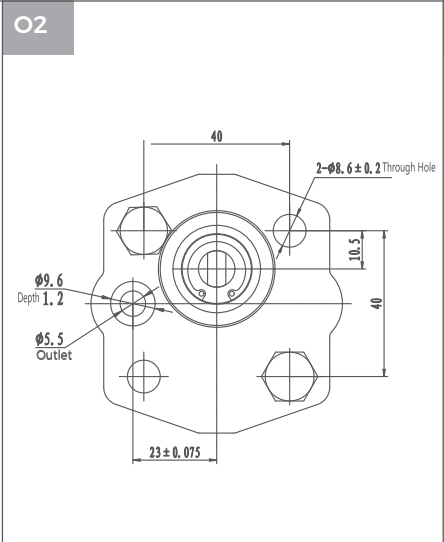
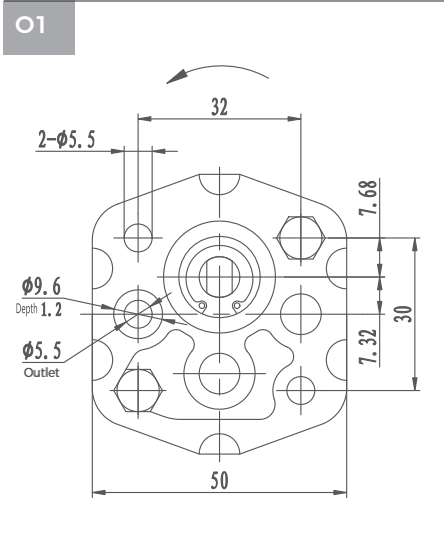

### Square Type Front Covers

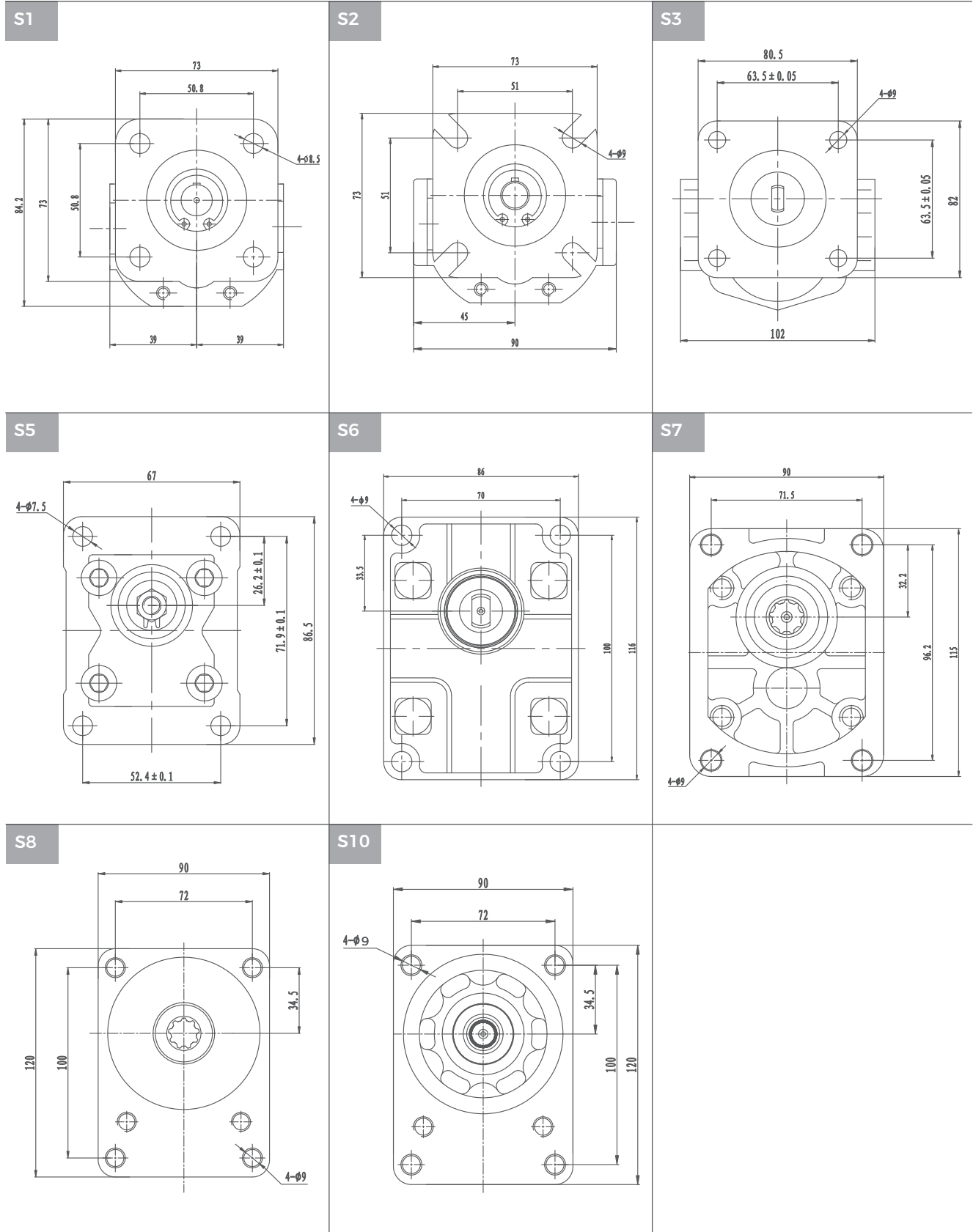



## Square Type Front Covers

S11

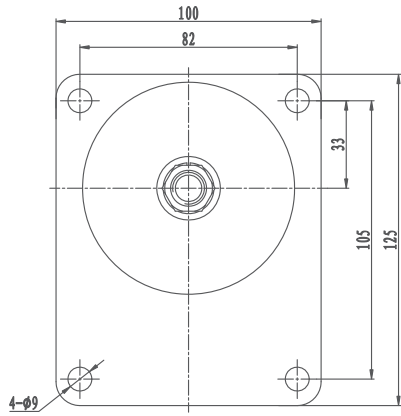

S14

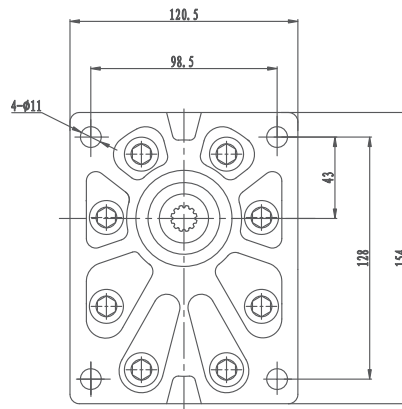

S18

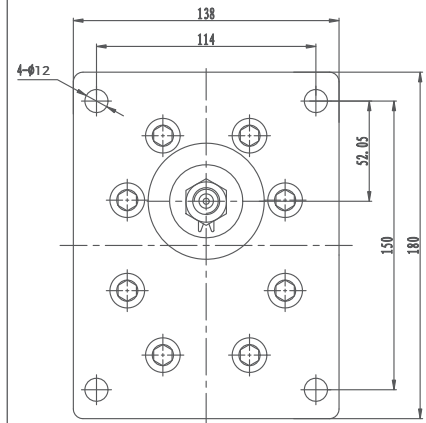

S19

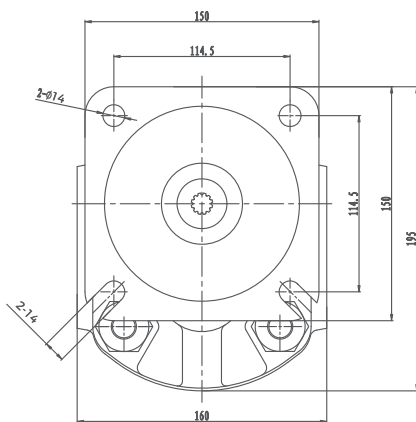

### Special Type Front Covers

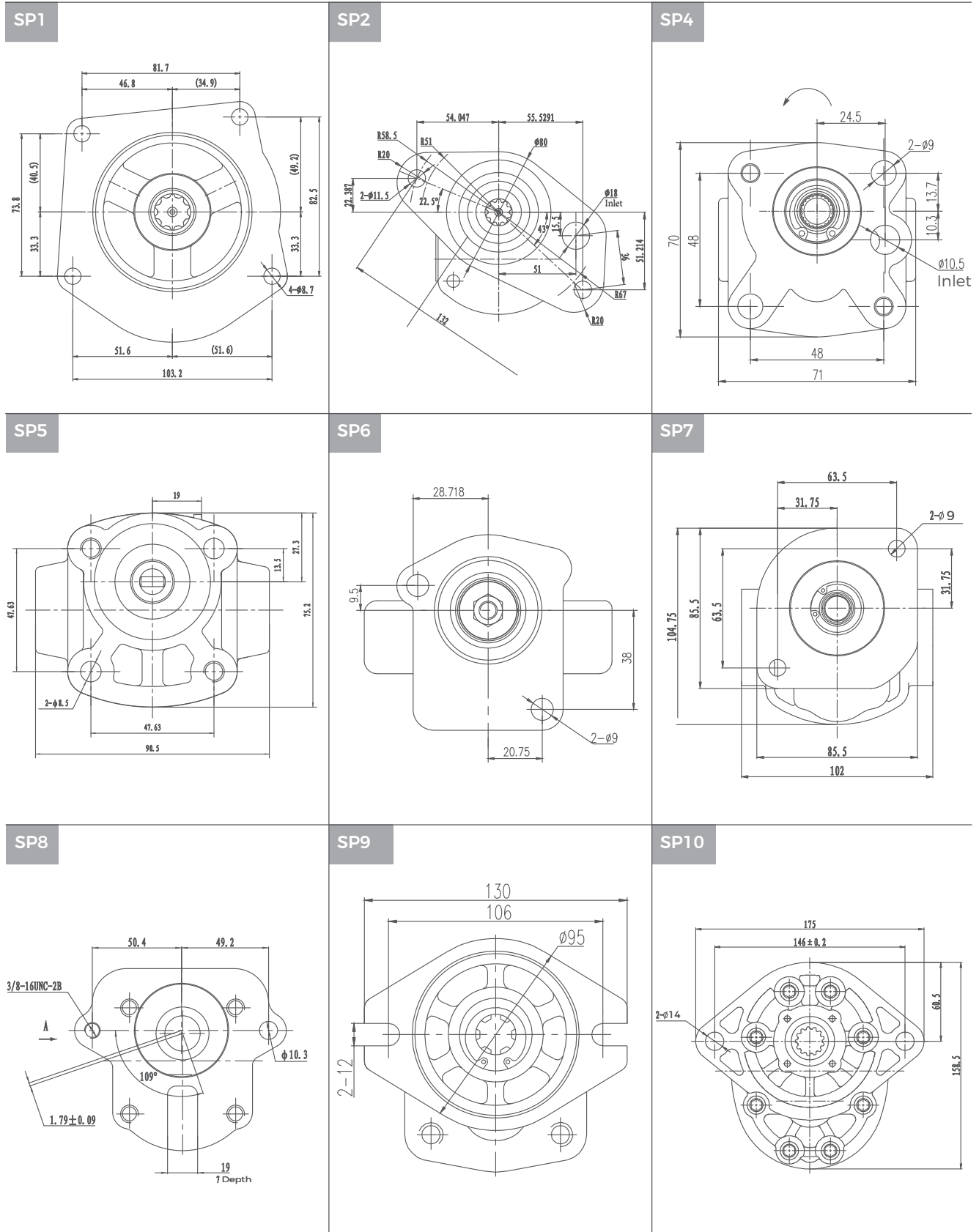



## Shanghai Guorui Hydraulic Technology Co., Ltd

Add. Room 2201-2202, 1717 North Sichuan Road,  
Hongkou Shanghai, China  
P.C. 200080  
Tel. +86-21-6218 3268  
Mail. [info@grhcn.com](mailto:info@grhcn.com)

Add. 666 West Shuanghu Road, Hi-tech Zone,  
Jianhu Yancheng, Jiangsu, China  
P.C. 224700  
Tel. +86 0515-86316688 +86 400 188 1986  
Mail. [info@grhpro.com](mailto:info@grhpro.com)

