

Electric Stacker Power Pack

Introduction

1. High pressure gear oil pump / DC motor / Single acting
2. All electric

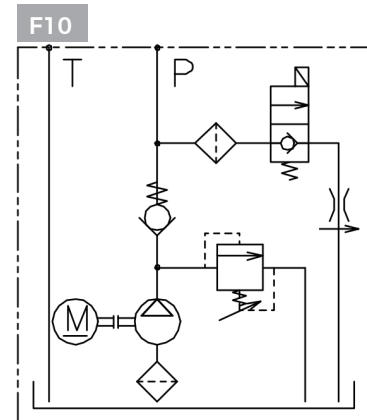

Technical Data

Model	DC-F10-3.7/E-2.2/24/2900-14H-D
Voltage	DC24V
Power	2.2kW
Speed	2900rpm
Disp.	3.7cc/r
Pressure	16MPa
Volume	14L
Size	P, T: G3/8

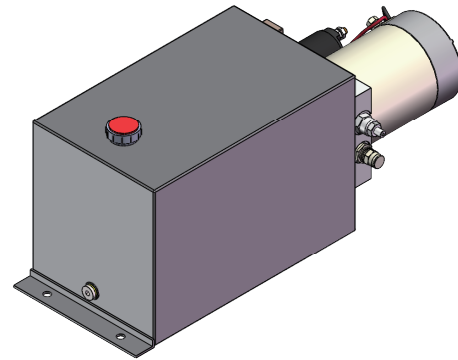

Drawing

